



iceWorkflow Designer
User Manual
Server Version 13.x

Copyright © 2024 Computer Talk Technology, Inc. All rights reserved.

No part of this publication may be reproduced, transmitted, or translated in any form or by any means, electronic, mechanical, manual, optical or otherwise, including photocopying, recording, or any information storage and retrieval system, without the prior permission in writing from Computer Talk Technology, Inc.

ComputerTalk Trademarks

ice, iceAdministrator, iceAlert, iceBar, iceBar for web, iceBar for Teams©, iceCampaign, iceChat, iceJournal, iceManager, iceMobile Connect, iceMonitor, icePay, iceReporting, iceSurvey, iceWorkflow Designer are trademarks of ComputerTalk Technology, Inc.

Microsoft, Excel, and Windows are either registered trademarks or trademarks of Microsoft Corporation in the United States and/or other countries.

Adobe, Acrobat, and Reader are either registered trademarks or trademarks of Adobe Systems Incorporated in the United States and/or other countries.

All other company and product names used herein may be the trademarks or registered trademarks of their companies.

Microsoft product screen shot(s) reprinted with permission from Microsoft Corporation.

Part Number: UM_WF_13.x_20240307

iceAdministrator Version 13.x

Table of Contents

TABLE OF CONTENTS	III
TABLE OF CONTENTS	III
WELCOME TO ICEWORKFLOW DESIGNER	XI
CHAPTER 1: INTRODUCTION TO WORKFLOW	1
NAVIGATING TO A WORKFLOW PAGE	2
SEARCHING FOR AN ACTION	6
VIEWING AN ACTION	8
<i>Viewing Actions on the Workflow Page</i>	<i>8</i>
<i>Viewing the Properties of an Action</i>	<i>11</i>
VIEWING A LINK	13
UNDERSTANDING WORKFLOW	16
<i>Workflow for Voice Calls</i>	<i>16</i>
<i>Workflow for Email Messages</i>	<i>19</i>
<i>Workflow for IM Messages</i>	<i>21</i>
ADDING A WORKFLOW GRAPH AND PAGE	23
CONFIGURING THE WORKFLOW ACTION TOOLBAR	25
PLACING ACTIONS ON THE WORKFLOW PAGE	28
RIGHT-CLICKING ON ACTIONS	31
FORMING LINKS BETWEEN ACTIONS AND WORKFLOW PAGES	34
<i>Forming Links between Actions</i>	<i>34</i>
<i>Hiding Incoming Links</i>	<i>38</i>
<i>Using Link Router to Link Actions</i>	<i>40</i>

<i>Forming Links between Pages</i>	41
LOGGING ACTIVITY FOR AN ACTION	44
DEFINING THE STARTING POINT	45
MOVING ACTIONS ON A WORKFLOW PAGE.....	48
ALIGNING ACTIONS ON A WORKFLOW PAGE	49
COPY/CUT AND PASTE ACTIONS.....	51
MOVING LINKS	53
ADDING AN ACTION TO WORKFLOW.....	55
DELETING ACTIONS	58
DELETING A WORKFLOW PAGE.....	60
DELETING A WORKFLOW GRAPH	61
EMPTYING THE WORKFLOW FOLDER.....	62
VALIDATING WORKFLOW.....	63
CHAPTER 2: AUDIO MESSAGES	67
VIEWING AUDIO MESSAGES.....	68
<i>General Audio Message Properties</i>	71
<i>Specific Audio Message Properties</i>	71
ADDING AN AUDIO MESSAGE GROUP	73
ADDING AN AUDIO MESSAGE	75
<i>Adding a New Audio Message</i>	75
<i>Adding Multiple Audio Messages</i>	77
<i>Adding an Audio Message from the Properties of an Action</i>	81
<i>Adding an Audio Message to a Base Subdirectory</i>	85
MOVING AN AUDIO MESSAGE.....	87
RECORDING A MESSAGE.....	90
<i>Recording a Message with System Administration</i>	90
DELETING AN AUDIO MESSAGE.....	93

DELETING AN AUDIO MESSAGE GROUP	95
EMPTYING THE AUDIO MESSAGES FOLDER.....	97
CHAPTER 3: HOLIDAYS	99
VIEWING HOLIDAYS.....	100
ADDING A HOLIDAY	102
DELETING A HOLIDAY	103
EMPTYING THE HOLIDAYS FOLDER.....	104
CHAPTER 4: VARIABLES	105
USER-DEFINED VARIABLES.....	106
<i>Variable Scope</i>	106
<i>Viewing User-Defined Variables</i>	107
<i>User-Defined Variable Properties</i>	110
SYSTEM VARIABLES.....	113
ADDING VARIABLES IN THE TREE VIEW.....	121
ADDING VARIABLES FROM THE PROPERTIES OF AN ACTION.....	123
<i>Creating Variables in Variable Fields</i>	123
<i>Creating Variables in Other Fields</i>	126
DELETING A VARIABLE	128
EMPTYING A VARIABLES FOLDER	129
PURGING UNUSED VARIABLES.....	130
CHAPTER 5: BUILDING BLOCKS	131
VIEWING BUILDING BLOCKS	132
<i>Navigating to a Building Block</i>	132
<i>Building Block Audio Messages</i>	133
<i>Viewing a Routine</i>	134
<i>Routine Properties</i>	135

ADDING A BUILDING BLOCK.....	137
<i>Changing a Building Block Access Level</i>	138
<i>Setting Passwords</i>	140
<i>Changing the Building Block Name</i>	141
ADDING A ROUTINE	143
<i>Defining the Routine Entry Point</i>	144
<i>Changing the Routine Name</i>	145
<i>Routine Access: Public or Private</i>	147
<i>Adding Arguments</i>	148
DELETING A ROUTINE	151
DELETING A BUILDING BLOCK	152
EMPTYING THE BUILDING BLOCKS FOLDER	153
CHAPTER 6: STANDARD ACTIONS	154
STANDARD WORKFLOW ACTIONS DEFINED	155
ASSIGN DN	160
ASSIGN SKILLS TO OBJECT	162
ASSIGN VALUE TO VARIABLE	166
CHECK ANI	171
CHECK DNIS	174
CHECK TIME SCHEDULE	177
COMMENT	181
COMPARE DATA.....	183
CONNECTOR IN.....	188
CONNECTOR OUT	190
DIAL DIGITS.....	192
EVALUATE EXPRESSION	194
GET CALLER INPUT	214

<i>Completing General Properties</i>	215
<i>Completing Properties for Multiple Digit Responses</i>	216
<i>Completing Single Digit Responses Properties</i>	218
<i>Completing Properties for Invalid Input & Timeout</i>	219
GET QUEUE STATUS	221
END WORKFLOW SESSION	226
LINK ROUTER	227
PLAY AUDIO FILE	228
PLAY MUSIC ON HOLD	232
QUEUE OBJECT	235
RECORD AUDIO FILE	239
<i>Completing General Properties</i>	239
<i>Completing Properties for Record Options</i>	241
<i>Completing Properties for Edit Options</i>	243
REJECT CALL	245
REMOVE OBJECT FROM QUEUE	248
REMOVE SKILLS FROM OBJECT	250
ROUTE OBJECT	252
SET AUDIO FILE BASE SUBDIRECTORY	254
WAIT FOR INCOMING CALL	256
CHAPTER 7: ADVANCED ACTIONS	259
ADVANCED WORKFLOW ACTIONS DEFINED	260
USER CONTROL	262
<i>General Properties</i>	263
<i>Get Property</i>	265
<i>Set Property</i>	274

<i>Class of Service</i>	278
<i>Issue 'Logoff' Command</i>	280
<i>Issue 'Logon' Command</i>	282
<i>Issue 'Place Call' Command</i>	284
<i>Issue 'Quick Text' Command</i>	285
<i>Issue 'Set LOB' Command</i>	287
<i>Issue 'Silent Monitoring' Command</i>	289
<i>Issue 'Toggle Ready State' Command</i>	291
<i>Validate DTMF Password</i>	292
<i>Validate Password</i>	294
CALL WEB SERVICES	296
CREATE AUTO DIAL REQUEST.....	302
GET OBJECT USER DATA.....	305
GET TELEPHONY PARAMETER	307
EXECUTE BUILDING BLOCK ROUTINE.....	310
EXECUTE EXTERNAL ACTION.....	313
<i>Dynamic Link Library</i>	313
<i>Executable or Command File</i>	319
EXIT BUILDING BLOCK ROUTINE	322
MAKE CALL.....	323
OBTAIN LOCK	331
OUTPUT DEBUG STRING	333
RELEASE LOCK.....	335
SET USER WHISPER	336
SET OBJECT USER DATA	340
SET TELEPHONY PARAMETER.....	342
RECORDING CONTROL.....	345

VIRTUAL WORKFLOW	348
ADD ACTIVE WORKFLOW	351
REMOVE ACTIVE WORKFLOW.....	354
CHAPTER 8: DATABASE ACTIONS	357
DATABASE WORKFLOW ACTIONS DEFINED	358
DB CONNECT	359
DB EXECUTE QUERY	362
DB NEXT RECORD.....	366
DB BEGIN TRANSACTION.....	369
DB END TRANSACTION	371
DB CLOSE HANDLE	373
CHAPTER 9: EMAIL ACTIONS	375
EMAIL WORKFLOW ACTIONS DEFINED	377
CHECK E-MAIL	378
COMPOSE REPLY	381
SEND EMAIL.....	383
WAIT FOR EMAIL.....	387
MANAGING USER ROUTING.....	389
CHAPTER 10: IM ACTIONS.....	391
IM WORKFLOW ACTIONS DEFINED	393
RECEIVE INSTANT MESSAGE	394
REPLY INSTANT MESSAGE	396
WAIT FOR INSTANT MESSAGE	398
CHAPTER 11: VOICE I/O ACTIONS.....	400
VOICE I/O ACTIONS DEFINED	401
TEXT-TO-SPEECH	402

SPEAK.....	403
<i>Text-to-Speech Voices</i>	407
SPEECH RECOGNITION.....	408
<i>DTMF-Centric Applications</i>	408
<i>Speech Recognition-Centric Applications</i>	410
ALLOCATE SPEECH RECOGNITION RESOURCE	412
FREE SPEECH RECOGNITION RESOURCE	414
GET SPEECH RECOGNITION RESULT	416
START SPEECH RECOGNITION.....	418
<i>Recognition Results Format String</i>	422
CHAPTER 12: SURVEY ACTIONS	425
SURVEY ACTIONS DEFINED	426
ADD OR UPDATE SURVEY.....	427
REMOVE SURVEY.....	431
SET SURVEY RESPONSE STATE	433
APPENDIX A: NETWORK TRANSFER MODE.....	436
SIP REFER TRANSFER	436
APPENDIX B: RESULT CODES	438
APPENDIX C: SURVEY RESPONSE STATE DIAGRAM.....	458
INDEX.....	460



Welcome to iceWorkflow Designer

As email and web-based communications become more common in today's business world, many call centers are evolving into **contact centers**. Contact centers interact with clients over the telephone, through email messages, and over the Internet.

ice is a powerful contact center solution that allows for the integrated handling of **contacts** (calls, email messages, chat requests, etc.) that are directed to your contact center. **iceAdministrator** is the application that will help you manage your contact center from your desktop. **iceWorkflow Designer** is the tool within iceAdministrator that will help you design and create contact flow and contact treatments.

The *iceWorkflow Designer User Manual* will help Supervisors, and ice Administrators understand the components of iceAdministrator that are found in the Workflow folder. For all other components of ice Administrator, please refer to the *iceAdministrator User Manual*. Chapter 1 provides information on viewing audio messages, holidays, variables, and workflow. Each subsequent chapter provides information on creating, modifying, and deleting workflow components.

This manual assumes that you:

- Are familiar with the contents of the *iceBar User Manual*;
- Are familiar with the contents of the *iceAdministrator User Manual*;
- Understand basic telephony terms and concepts, such as queue and contact;
- Have basic navigating skills for standard Windows®-based graphical user interfaces. This includes the ability to right-click and left-click, select options from a right-click menu, resize and minimize windows and navigate and scroll with a mouse pointer.

The following conventions are used in this manual:

- **Notes** highlight important information.
- **Cautions** are used to bring attention to functions and features that can affect the information viewed.
- Words displayed in **bold** font are defined in the paragraph.
- *Italics* are used to indicate buttons found on the software interface.
- The term "right-click" is used to indicate that the secondary mouse button, which by default is the button on the right, should be clicked. This configuration can be changed so that the left mouse button is the secondary button (for personal preference, for example, if the user is left-handed.)



Chapter 1: Introduction to Workflow

Workflow is implemented into each ice system designed to suit your contact center's needs. Workflow consists of a series of actions that, when linked together, create logical routing for contacts.

Although many systems might not require changes to the initial workflow design, you may wish to review the workflow that has been implemented for your contact center. The more familiar you are with the components of workflow and with existing workflow configuration, the more likely you will understand which parts of workflow require changes when your contact center's needs updating.

The following sections will:

- Explain how to navigate to a workflow page and view the actions and links that make up the workflow.
- Describe how to create, modify, and delete actions, links, pages, and graphs.

Subsequent chapters provide details on the other components of the Workflow folder: Audio Messages, Building Blocks, Holidays, and Variables.

Navigating to a Workflow Page

Viewing your existing workflow involves finding and selecting a workflow page in the tree view. A **workflow page** is often referred to as a “canvas” because it acts as a backdrop upon which workflow is designed. When a workflow page is selected in the tree view, the detail view displays the workflow that has been designed on that page.

A **workflow graph** holds one or more pages that may or may not be linked together. Consider the following examples:

- Workflow can become so large that it requires two workflow pages. These two pages are housed in the same workflow graph.
- Workflow graphs may be used to group similar pages. For example, all queuing workflow may be developed on pages that are housed in the same workflow graph.

Note: Workflow graphs and pages can also be found in building blocks. For more information, refer to Chapter 5: Building Blocks.

To view a workflow page:

1. Double-click the Workflow folder in the tree view. Along with the Audio Messages, Building Blocks, Holidays and Workflow Variables folders, one or more workflow graphs are displayed.
2. Double-click the appropriate workflow graph in the tree view.

Along with the Graph Variables folder, one or more workflow pages are displayed, depending on the configuration of ice. Six workflow pages are shown below.

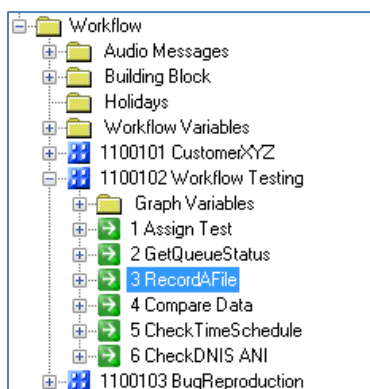

3. Click on the workflow page that you wish to view.

Three tabs appear in the details view on the right side of the iceAdministrator window. By default, the 'Properties' page is displayed. On this page, you will see the Page Name and Page ID. You can modify the name by highlighting and typing over the existing page name. The name automatically updates.

The screenshot shows the 'Properties' tab of the iceWorkflow Designer interface. It contains two input fields: 'Page Name' with the value 'Record&File' and 'Page ID' with the value '3'. Below these fields is a blue 'Open' button.

- Click the 'Variables' tab to bring that page to the front.

The 'Variables' page shows a list of variables that are used on the workflow page, as well as the action name, ID, and field where the variables are used. For more information on variables, refer to Chapter 4: Variables.

The screenshot shows the 'Variables' tab of the iceWorkflow Designer interface. It displays a table titled 'List of Variables Used' with the following columns: Variable, Field, Action ID, and Action Name. The table contains 27 rows of data.

Variable	Field	Action ID	Action Name
@p_action	VARIABLE	5	Get Caller Input
@p_action	VARIABLE	13	Compare Data
@p_action	VARIABLE	13	Compare Data
@p_action	VARIABLE	13	Compare Data
@p_action	VARIABLE	13	Compare Data
@p_action	VARIABLE	13	Compare Data
@p_action	VARIABLE	22	Get Caller Input
@p_action	VARIABLE	29	Acknowledge
@p_fileExtension	VALUE	16	Add .ext
@p_fileExtension	VARIABLE	2	.wma
@p_fileExtension	VARIABLE	33	.wav
@p_fileExtension	VARIABLE	34	.vox
@p_filename	AUDIO_FILE	15	Play Audio File
@p_filename	AUDIO_FILE	18	Record File
@p_filename	AUDIO_FILE	19	Play Audio File
@p_filename	PARAMETER1	27	Evaluate Expression
@p_filename	TEXT	23	Speak
@p_filename	TEXT	24	Speak
@p_filename	TEXT	26	Speak
@p_filename	VALUE	16	Add .ext
@p_filename	VARIABLE	4	Get Caller Input
@p_filename	VARIABLE	16	Add .ext
@p_result	RESULT	27	Evaluate Expression
@p_terminator	VARIABLE_TERM	4	Get Caller Input
@VniceContact	OBJECT	1	Assign DN

- Click the 'Audio Messages' tab to bring that page to the front.

A list of audio messages used on the workflow page is displayed. The table also displays the action name, ID, and field where each message is used.

For more information on audio messages, refer to Chapter 2: Audio Messages.

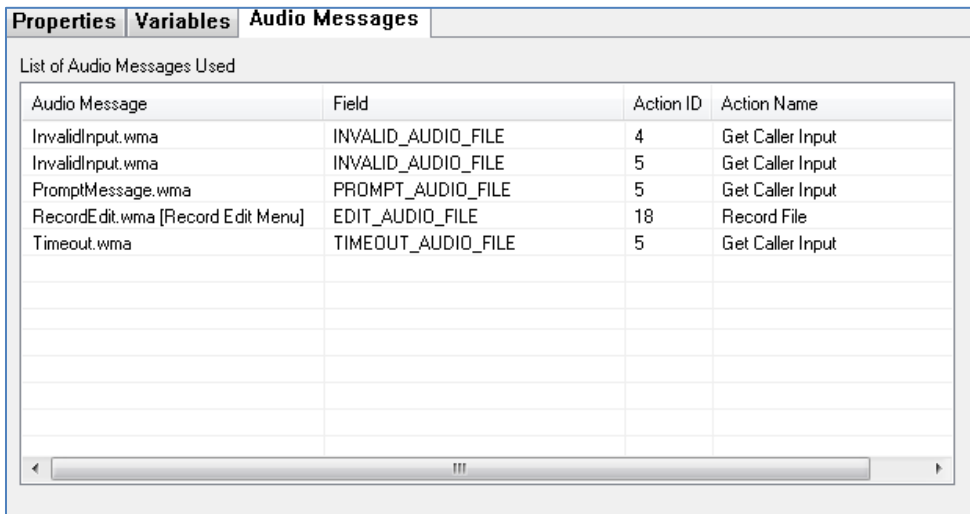

Audio Message	Field	Action ID	Action Name
InvalidInput.wma	INVALID_AUDIO_FILE	4	Get Caller Input
InvalidInput.wma	INVALID_AUDIO_FILE	5	Get Caller Input
PromptMessage.wma	PROMPT_AUDIO_FILE	5	Get Caller Input
RecordEdit.wma [Record Edit Menu]	EDIT_AUDIO_FILE	18	Record File
Timeout.wma	TIMEOUT_AUDIO_FILE	5	Get Caller Input

- Go to the 'Properties' tab and click *Open* to view the workflow page in the detail view.

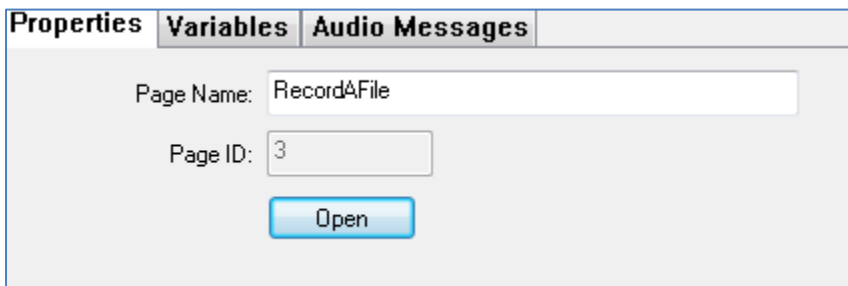

Properties Variables Audio Messages

Page Name:

Page ID:

You may also double-click on the workflow page in the tree view to open the page, or right-click on the workflow page in the tree view and select 'Open' from the menu.

The workflow that has been designed on the selected page is displayed on the right side of iceAdministrator. Workflow is made up of actions and links, which will be discussed in the sections that follow.

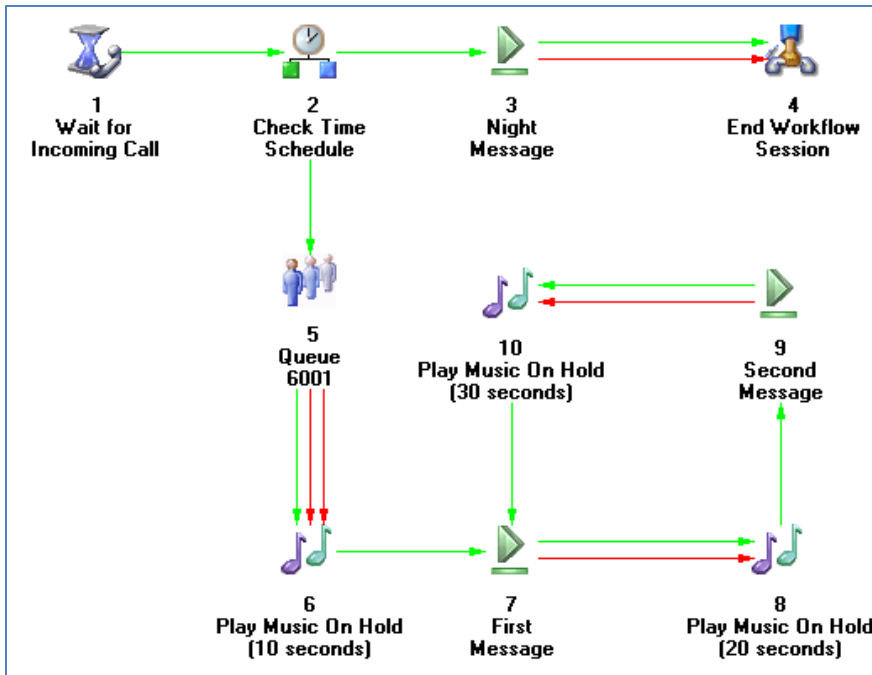

Note:

- A workflow graph also has the 'Variables' and 'Audio Messages' tabs. These tabs can be used to view all of the variables and audio messages that are used within the workflow graph.
- Each workflow page has a Page Variables folder, which contains variables specific to the page. For more information on variables, refer to Chapter 4: Variables.

Searching for an Action

When you click on the Workflow folder, a 'Search' page appears on the right side of iceAdministrator.

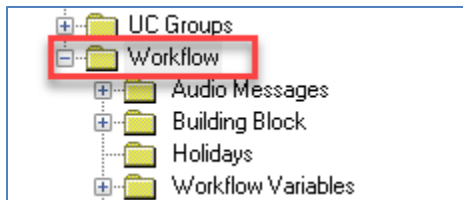

You can search for actions by their action name or by any values in their property fields, including variable IDs. Enter the search term into the text box provided and click *Search*. The results appear in the list below.

Search

Find Workflow Action containing text:

Search Results: 31 item(s) found Search Go To Target

Graph	Page ID	Page	Action ID	Action
1100101 CustomerXYZ	1	Start Page	15	Assign DN
1100101 CustomerXYZ	1	Start Page	16	Assign DN
1100101 CustomerXYZ	2	Email	11	Assign DN
1100101 CustomerXYZ	3	Route	15	Assign DN
1100102 Workflow Testing	1	Assign Test	1	Assign #
1100102 Workflow Testing	1	Assign Test	7	Self Assign
1100102 Workflow Testing	1	Assign Test	7	Self Assign
1100102 Workflow Testing	1	Assign Test	8	Assign DN
1100102 Workflow Testing	1	Assign Test	9	Assign Strings
1100102 Workflow Testing	1	Assign Test	10	assign stringvalue fail
1100102 Workflow Testing	1	Assign Test	10	assign stringvalue fail
1100102 Workflow Testing	1	Assign Test	13	assign numeric
1100102 Workflow Testing	1	Assign Test	13	assign numeric
1100102 Workflow Testing	1	Assign Test	14	assign default fail
1100102 Workflow Testing	1	Assign Test	16	Self Assign
1100102 Workflow Testing	1	Assign Test	16	Self Assign
1100102 Workflow Testing	1	Assign Test	20	assign fail
1100102 Workflow Testing	1	Assign Test	20	assign fail
1100102 Workflow Testing	1	Assign Test	21	Chain Assign
1100102 Workflow Testing	1	Assign Test	21	Chain Assign
1100102 Workflow Testing	1	Assign Test	24	assign numeric
1100102 Workflow Testing	1	Assign Test	24	assign numeric

You can sort the list by different column headings by clicking on those column headings. If you double-click an action so that it is highlighted and click the *Go To Target* button, you are taken to the workflow page that contains the action of interest. It will be selected on the page.

Viewing an Action

Each icon shown on a workflow page represents an action or a single step in the workflow.

An action can:

- play a message
- play music
- prompt the caller to enter information such as an account number
- scan an incoming call for the dialed number
- scan an incoming email for a keyword
- route callers and email messages to a particular queue

The different action types are fully explained in Chapters 6 through 11.

Viewing Actions on the Workflow Page

You may view the actions on a workflow page by following the steps that were described in [Navigating to a Workflow Page](#) on page 2.

Each action consists of:

- An icon that corresponds with the action type. The icons for the different action types can be found in [Chapter 6: Standard Actions](#).
- An action ID that is displayed directly beneath the icon. The action ID number is assigned when the action is added to the workflow page. This number is used to identify the action. The action ID has no effect on how workflow runs.
- The action name is displayed directly beneath the action ID. The action name is configured when the workflow is built. For more information, refer to ['Placing Actions on the Workflow Page'](#) on page 28.
- You may mouse over an action to view some of the action's properties in a tooltip.

Play Music on Hold
Play Music from Broadcaster
Duration on Hold: 30000(ms)



1
Play Music on
Hold

Note:

- An action with incomplete properties is displayed with a red background. The background remains red until all the required properties have been completed for that particular action.
- If you are importing workflow from a previous version, actions that are no longer supported will also be displayed with a red background. You cannot save the workflow until unsupported workflow actions, specified by confirmation messages, are deleted. Specific instructions on completing the properties of each action type can be found starting on page 154.
- An action that has been selected as the terminus for a contact group is displayed with a yellow background. If you right-click on the action and select 'Origin Contact Groups' from the menu, you will see a list of the contact groups for which this action is the terminus.
- An action that has been selected as the entry point for a building block routine is displayed with a green background. For more information on building blocks, refer to Chapter 5: Building Blocks.

This section has described the information you can view for an action while on a workflow page. The next section provides more information on viewing an action's properties.

Viewing the Properties of an Action

Properties are unique for each action since each action completes a different task. For example, *Play Music on Hold* is an action that plays music to callers as they wait in queue for the first available user. In the 'Properties' page of this action, you can see how long the music will play for before the contact goes to another action in the workflow.

All actions have the following in their 'Properties' page:

- A title bar, which displays the action ID number and the action type (e.g., 8: Play Music on Hold). The ID number is assigned to the action when you add it to the page (e.g., the first action you add to the page will have the Action ID of "1"). It does not indicate the order in which the action will be played.
- Required fields highlighted in yellow. If these fields are not completed when the properties dialog box for the action is closed, the action is highlighted in red on the workflow page, indicating the action is incomplete.
- A 'Hide Incoming Links' checkbox. When this feature is enabled, the links that terminate on this action are not displayed. For more information on links, refer to the next section.
- A 'Log Action' checkbox. When this feature is enabled, you can retrieve details about activity for the action from iceReporting. For example, reports can provide timestamps for each contact that has passed through to a specific action. For more information on reports, refer to the *iceReporting User Manual*.
- For fields where you must make a selection from a dropdown list, you can select the appropriate "<NEW>" option in the list to create a new audio message, user, skill, queue, or workflow variable. You can also right-click on the arrow in the dropdown list, and make the same selection from the menu that appears. The only menu or dropdown list options available are ones that relate to the particular field.
- You can enable shortcut keys on an action's properties dialog box by pressing the Alt key.

To view the properties of an action:

1. Navigate to the appropriate workflow page.
2. Double-click an action or right-click the action and select 'Properties' from the menu.

A dialog box opens showing the properties specific to that action type. The properties dialog box shown below indicates that a caller hears music for fifteen seconds before proceeding to the next action (in this example, the caller is sent to

'Get Queue Status' action after the caller has been in the Play Music on Hold action for 15000 milliseconds).

The screenshot shows a dialog box titled "35: Play Music on Hold" with a close button (X) in the top right corner. The dialog contains the following fields and controls:

- Action Name:** A text field containing "Play Music on Hold" with a yellow highlight. To its right is a "Set Default" button.
- Play Music from Broadcaster:** A checked checkbox.
- Message Name:** A dropdown menu.
- Duration on Hold (ms):** A dropdown menu showing "15000" with a yellow highlight.
- Play To:** A section containing two checkboxes: "Caller" (checked) and "Callee" (unchecked).
- Go To:** A dropdown menu.
- Link Name:** A text input field.
- Hide Incoming Links:** An unchecked checkbox.
- Log Action:** An unchecked checkbox.
- Buttons:** "OK" and "Cancel" buttons at the bottom right.



3. Click *Cancel* to close the properties dialog box.

This section has explained how to view the properties of an action that is part of the workflow page. The following section describes how actions can be linked together to create a workflow.

Viewing a Link

A link is represented on the workflow page as an arrow between actions, indicating the next action contacts are directed to as they move through the workflow. Depending on the action that you are viewing, there may be a single link or multiple links to other actions. The number of links required for a specific action depends on its action type and the way it is configured.

Links are color coded:

-  A green link indicates success (e.g., if a caller makes a valid selection in the Get Caller Input action).
-  A red link indicates failure (e.g., if the caller does not make a selection or the action fails in the Get Caller Input action).
-  A blue link indicates a timeout has occurred (e.g., if the caller does not make a selection when prompted in the Get Caller Input action).

The image below shows an example of the multiple links that can be configured for the Get Caller Input action.

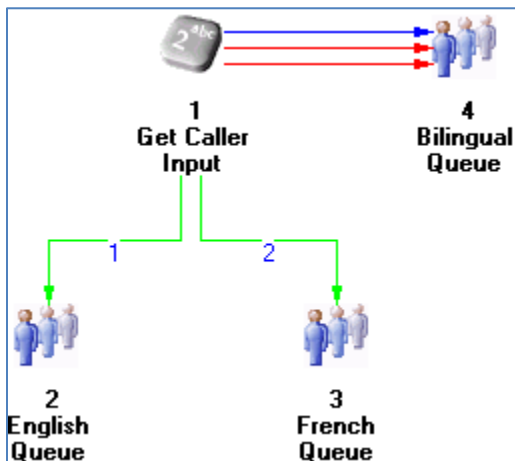

Note: Links can be hidden (e.g., to give workflow a more organized appearance). For more information on Hiding Incoming Links, refer to page 38.

The Get Caller Input action has been configured so that:

- If the caller presses 1, the call is directed to the English queue (represented by a green link).
- If the caller presses 2, the call is directed to the French queue (represented by a green link).

- If the caller makes no selection (i.e., the caller times out), the call is directed to the Bilingual queue (represented by the blue link).
- If the caller makes an invalid selection, the call is directed to the Bilingual queue (represented by a red link).
- If a failure happens within the action (e.g., a message fails to play), the call is directed to the Bilingual queue (represented by a red link).

To view more information about links for a specific action:

1. Double-click on an action to see its properties.

A dialog box opens showing the properties specific to that action type. The image below shows the properties for Get Caller Input.

The screenshot shows the 'English/French Queue' action properties dialog box. The 'Invalid Input & Timeout' section is highlighted with a red box, showing the following fields:

- Number of Retries: 3
- On Invalid Input Go To: 9 Speak Bye
- First Digit Timeout (ms): 5000
- Inter Digit Timeout (ms): 3000
- On Timeout Go To: 9 Speak Bye
- On Failure Go To: 9 Speak Bye

The 'Single Digit Response' section contains a table with the following data:

Digit	Go To	Link Name	Digit	Go To	Link Name	Digit	Go To	Link Name
1	3 Playing Get	1	2	11 Record Ge	2	3	12 Delete Get	3
4	9 Speak Bye	4	5	32 Record W/	5	6	7 Record VO	6
7		7	8		8	9		9
*	10 Connector	*	0		0	#		#

Notice the 'Go To' fields on the dialog box (e.g., 'On Timeout Go To'); a link is drawn between this action and the action that is specified in each of these 'Go to' fields.

2. When you are finished viewing the properties of the action, click *Cancel* to close the properties dialog box.

This section explained how links are used to direct contacts from one action to the next. While the 'Go to' fields that generate links are specific to each action type, selecting an action from these fields always results in a link being drawn from one action to another.

Understanding Workflow

The previous sections have provided information on navigating to a workflow page and viewing actions and links. While each of these sections explains important concepts, it is crucial that you understand how the concepts work together to create a workflow. Multiple actions and links placed on the workflow page create a workflow that determines how your contacts are treated.

The purpose of this section is to give you two simple examples of how workflow can be created to meet the requirements of a contact center. Apply what you learn from this section to the workflow that is in place for your contact center.

Workflow for Voice Calls

A contact center plans to create a workflow for incoming calls. All calls are to be directed to a queue between 7AM to 7PM, Monday to Friday. During office hours, callers listen to music and messages while waiting for the first available user. Outside of office hours, callers hear an "office closed" message before they are disconnected.

The following actions are required for this workflow: *Wait for Call*, *Check Time Schedule*, *Queue Object*, *Play Audio File*, *Hang Up*, and *Play Music on Hold*. The image below

illustrates the actions and links required to create the workflow that the contact center requires.

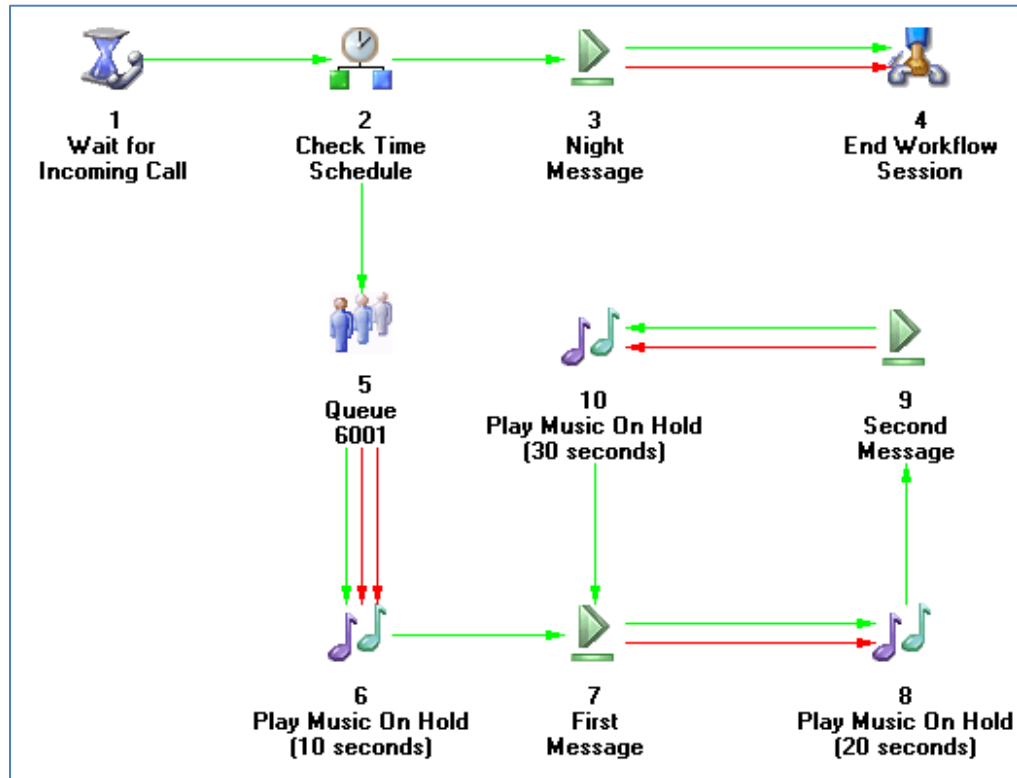

The way in which the actions are linked in the above example is described below:

- *Wait for Incoming Call* scans for an incoming call. This action gathers several pieces of information about a call, such as a number dialed and the number the caller has dialed from, once it arrives. This information is stored in system variables. A link sends the call to *Check Time Schedule*.
- *Check Time Schedule* makes routing decisions based on the time the call passes through this action. During office hours, a link sends the call to *Queue Object*.
- During office hours, *Queue Object* registers the call in the queue 6001. The call remains queued until a user is available, at which point the call is removed from workflow and answered by the user. A link will send the caller to *Play Music on Hold* if a user is not immediately available.
- *Play Music on Hold* plays music to the caller for a specific number of seconds as they wait in queue for an available user. If no users become available, the call is directed to the first *Play Audio File* action (named *First Message*).
- *Play Audio File* plays the first message to the caller as they wait in queue for the first available user. This action type appears multiple times in the workflow example. Each action of this type is labeled with a name that corresponds with the message that callers hear. A link sends the caller to *Play Music on Hold* when the message has completed playing. The example shows that the caller hears music after the second message, followed by the first message. The caller continues to hear the first and second messages, with intervals of music, until a user becomes available.
- Outside of office hours, a link sends the caller to *Play Audio File* to play a message indicating the office is closed. When the message has finished playing, a link sends the call to the *End Workflow Session* action.
- *End Workflow Session* disconnects the caller.

Workflow for Email Messages

To create a workflow for incoming email messages. All messages are to be directed to an email-only queue that is open 24 hours a day. When a message is queued, a reply is to be sent to the customer indicating that his or her message has been queued and will be answered by the first available user.

The following actions are required for this workflow: Wait for Email, Queue Object, Compose Reply, and End Workflow Session. The example below illustrates the actions and links required to create the workflow that the contact center requires.

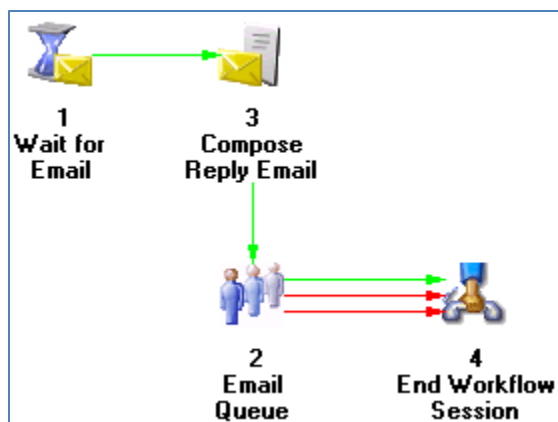

The way in which the actions are linked in the example is described below:

- *Wait for Email* scans for an incoming email message. This action gathers several pieces of information about the message, such as the email address to which the message was sent. This information is stored in system variables. A link sends the message to *Compose Reply Email*.
- *Compose Reply Email* sends an automatic response to the sender. For example, a reply to the sender's email can inform the sender that the message has been received and a reply from a user will be sent within 24 hours. A link sends the message to *Queue Object* (named *Email Queue*).
- *Queue Object* registers the message in the Email Queue. The message remains in the queue until a user is available, at which point the message is removed from workflow and presented to the user. The user will receive a notification message from iceBar, and the email message is sent from ice to the user's email client application. A link sends the email to *End Workflow Session* if a user is not immediately available.

- The message remains in the queue until it is received by the first available user. After the email message is in the queue, *End Workflow Session* is used as an end-point in the workflow.

Workflow for IM Messages

To create a workflow for incoming instant messages. All messages are to be directed to a queue that only handles instant messages. The queue is open 7AM to 7PM, Monday to Friday. During office hours, an automated response is used, indicating to the sender that his or her message has been received and that the sender has two routing options (i.e., reply with 1 for finance or reply with 2 for customer service). Outside of office hours, messages are not queued, and an automated response is used, telling senders that the office is closed.

The following actions are required for this workflow: *Wait for Instant Message*, *Receive Instant Message*, *Reply Instant Message*, *Queue Object*, and *End Workflow Session*. The example below illustrates the actions and links required to create the workflow that the contact center requires.

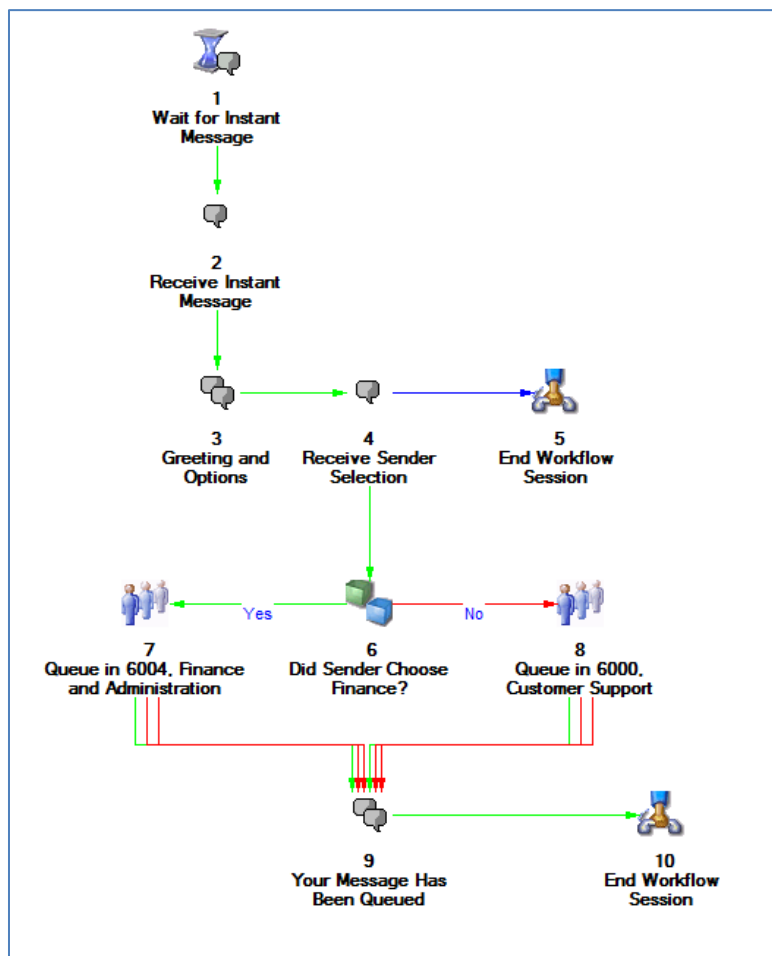

The way in which the actions are linked in the example is described below:

- *Wait for Instant Message* scans for an incoming instant message. This action gathers several pieces of information about the message, such as the IM address to which the message was sent. This information is stored in system variables. A link sends the message to *Receive Instant Message*.
- *Receive Instant Message* captures the sender's message so that it can be displayed once it is connected with a user. A link sends the message to *Reply Instant Message*.
- *Reply Instant Message* (named *Greeting and Options*) sends an automatic response to the sender. In this example, the reply greets the sender and provides them with two options (e.g., enter 1 for finance, or enter 2 for customer service). A link sends the caller to *Receive Instant Message* (named *Receive Sender Selection*).
- *Receive Instant Message* (named *Receive Sender Selection*) captures the sender's input. If the sender entered 1, they are directed to the finance queue. If the sender entered 2, they are directed to the customer service queue.
- *Reply Instant Message* (named *Your Message Has Been Queued*) sends an automatic response to the sender. In this example, the response informs the sender that the message has been queued.
- The message remains in the queue until it is received by the first available user. After the IM is in the queue, *End Workflow Session* is used as an end-point in the workflow.

This chapter has explained the basics of the workflow. The following chapters, which provide detailed information on creating and modifying the workflow, assume that you are familiar with viewing workflow.

Adding a Workflow Graph and Page

A workflow page is often referred to as a “canvas” because it acts as a backdrop upon which you design workflow. Workflow pages are contained and organized in Workflow Graphs. Typically a Workflow Graph holds all of the pages associated with a single application. A different application can be represented by another graph.

To add a workflow graph and page:

1. Right-click on the Workflow folder that is part of the tree view.

A menu appears.

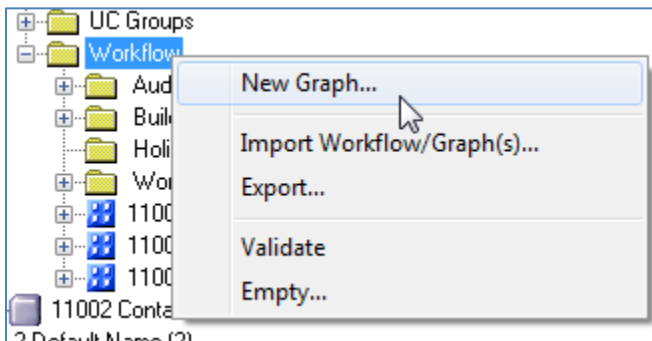

2. Select 'New Graph' from the menu.

The right side of the iceAdministrator displays the properties for the new graph.

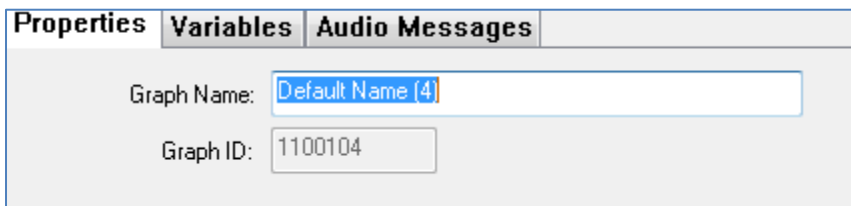

3. Type the name of the graph in the 'Graph Name' field.

The name can be up to 40 characters in length. Notice the new graph appears under the Workflow folder in the tree view with the name you just typed.

4. In the tree view, right-click the graph you just created.

A menu appears. Select 'New Page' from the menu.

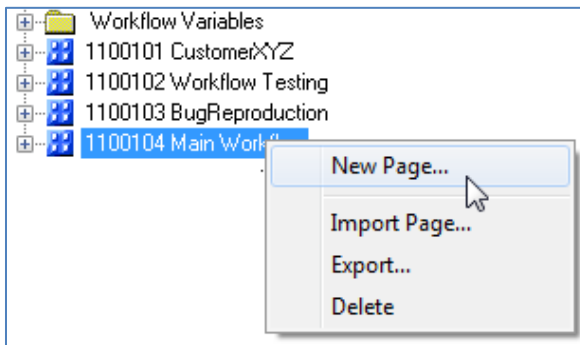

The right side of the iceAdministrator displays the properties for the new page.

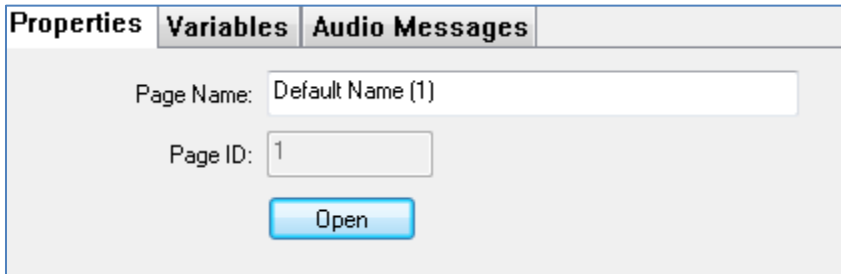

5. Type the name of the page in the 'Page Name' field.

The name can be up to 40 characters in length. Notice that the new page appears under the Workflow Graph in the tree view with the name you just typed.

6. From the File menu, choose 'Save.' (To cancel the save operation, click *Cancel* on the 'Progress' dialog box).

In this section, you have added a new workflow graph with one or more workflow pages. The next tasks involve selecting actions and placing them in a workflow page you have just created.

Configuring the Workflow Action Toolbar

The **Workflow Actions toolbar** appears on either side of the workflow page when you are in Edit Mode.

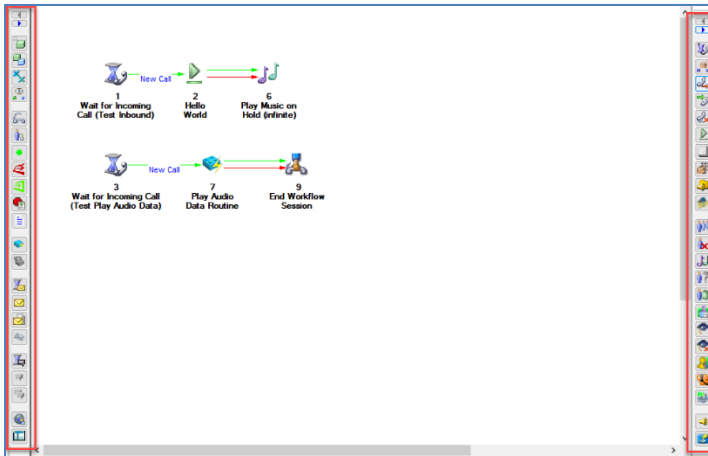

Note: The Workflow Action toolbar can be dragged to either the top or bottom of the workflow page. Click in an inactive grey area on the toolbar (i.e., not on a button) and drag the toolbar to its new location.

You can modify which actions appear on the Workflow Actions toolbar. For example, if you are not creating email or database workflow, you may want to remove the associated actions from the toolbar, so that the toolbar is less cluttered and so that you can find the actions you need more easily.

To edit the Workflow Actions toolbar:

1. Select 'Workflow Actions Toolbar' from the View menu.

This option is only available in the View menu when you have a workflow page open.

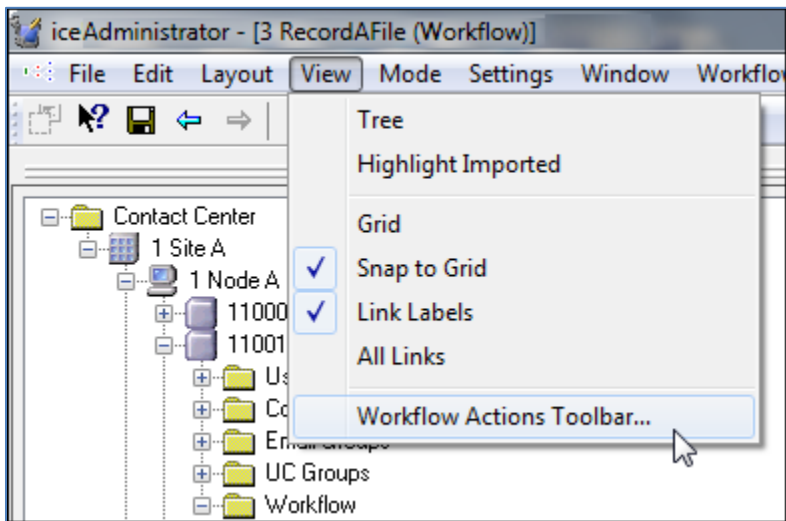

- The 'Show Workflow Actions' dialog box appears.

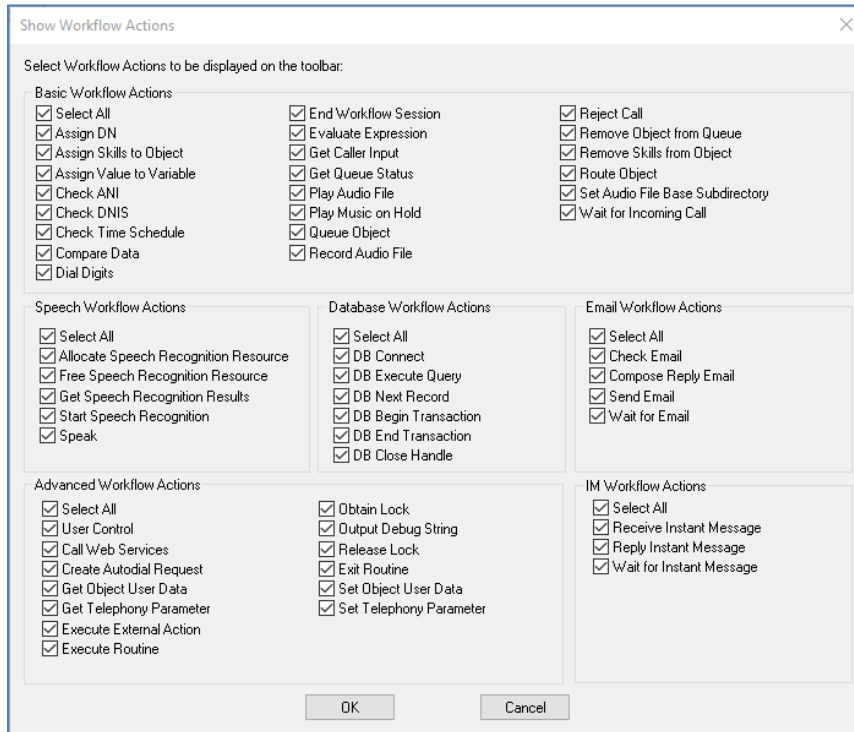

- Select the workflow actions that you want to see in the toolbar, or deselect the actions that you do not want to see.

You can quickly select or deselect an entire section by enabling or disabling the appropriate 'Select All' checkbox.

Note: There are several actions that are always visible on the Workflow Actions toolbar: Comment, Connector In, Connector Out, and Link Router.

- Click *OK* to save your changes, or click *Cancel* to discard them.

Placing Actions on the Workflow Page

The workflow page created in the *Adding a Workflow Graph and Page* section on page 23 is simply a blank canvas to which you must add actions. These actions can then be linked to create a workflow. Placing an action on the workflow page involves selecting the action from the Workflow Actions toolbar and then dragging and dropping the action anywhere on the workflow page.

To place an action on the workflow page:

1. From the Toolbar that appears on either side of the workflow page, click the button that represents the action you want to add to the workflow page.

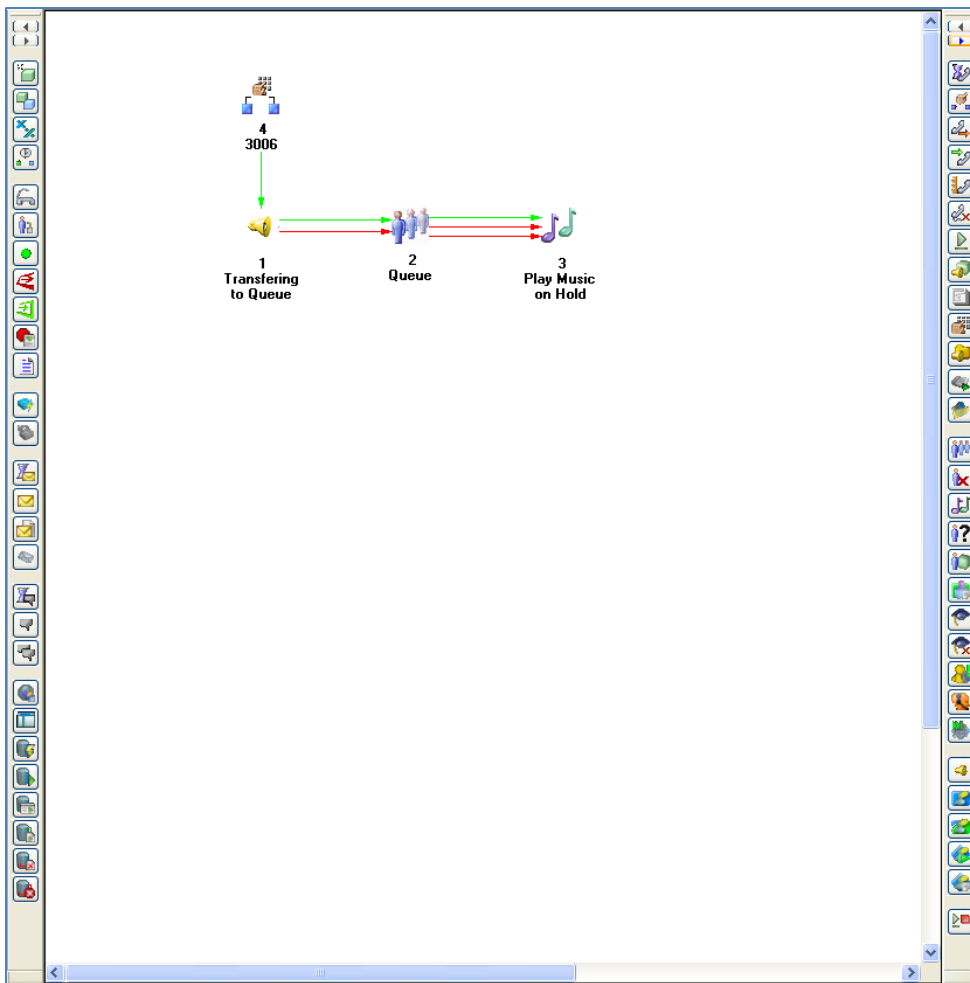

Note: If you are not sure which button represents the action you wish to add, hover your mouse pointer over the button until a tooltip, with the name of the action, appears.

2. Drag and drop the action onto the workflow page.

- The action is placed on the page, and the properties dialog box for the action opens. The *Play Music on Hold* properties dialog box is shown as an example below:

35: Play Music on Hold

Action Name:

Play Music from Broadcaster

Message Name:

Duration on Hold (ms):

Play To

Caller
 Callee

Go To

Link Name

Hide Incoming Links
 Log Action

Notice that the 'Action Name' field displays the name of the action. To change the name, type over the text. You can also click *Set Default*. Depending on the action, the name will update to reflect the properties you have chosen for the action or revert to the default action name (which corresponds with the action type).

35: Play Music on Hold

Action Name:

Play Music from Broadcaster

Message Name:

Duration on Hold (ms):

Play To

Caller
 Callee

Go To

Link Name

Hide Incoming Links
 Log Action

- The name that is entered in the *Action Name field* is displayed under the action on the workflow page.

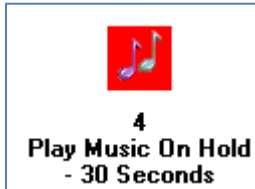

- If you have completed all of the action's properties, click *Save*.

To continue completing the properties of the action, refer to the next section for general information on forming links between actions and workflow pages.

Note:

- An action with incomplete properties is displayed with a red background. The background remains red until all the required properties have been completed for that particular action. Specific instructions on completing the properties of each action type can be found on page 154.
- You cannot save changes until all of the required properties have been completed for each action that is part of the workflow page. If you are not prepared to complete the required properties of certain actions, these actions must be removed from the workflow page before you can save your changes, or you can export the incomplete workflow. For more information on exporting, refer to the *iceAdministrator User Manual*.

Right-Clicking on Actions

There are several options available when you right-click on an action. The menu that appears is shown below.

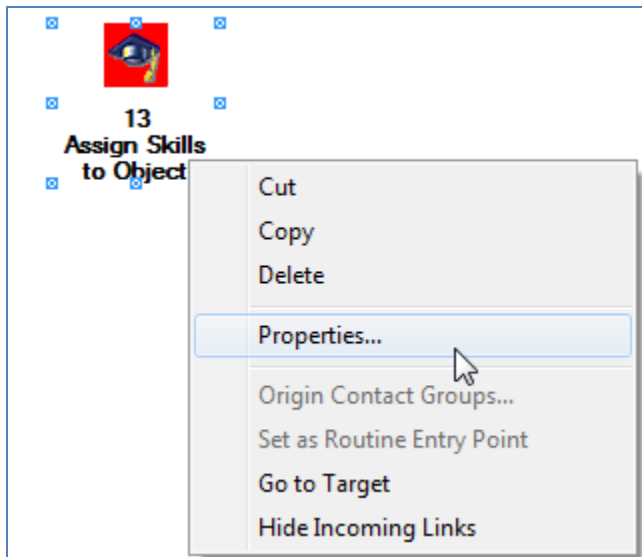

If you have selected multiple actions on a workflow page, you may right-click on any of the selected actions to cut, copy, or delete all of the selected actions.

Note: You may also select 'Properties' or 'Hide Incoming Links,' but these menu items only apply to the specific action on which you have right-clicked.

To select multiple actions on the workflow page:

- Choose 'Select All' from the Edit menu to select all actions on the workflow page.

OR

- Hold your left mouse button down, and use your mouse to draw a box around the actions you wish to cut, copy, or delete.

The image below shows the right-click menu when multiple actions have been selected.

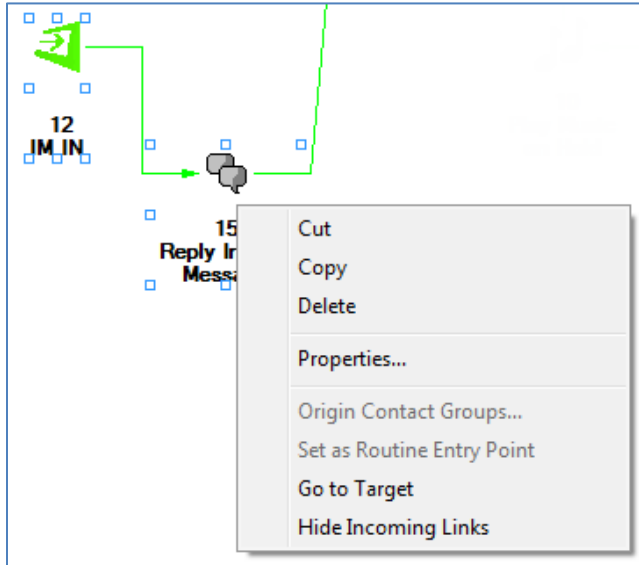

For more information on the options available in the menu for an action or group of actions, refer to the table below.

Action Menu Items	
Menu Item	Description
Cut	Cuts the selected action(s) from the workflow page. The action or actions is/are removed from the workflow page, and can be pasted on another workflow page. Note: Any existing links will be broken.
Copy	Copies the selected action(s) from the workflow page. A copy of the action(s) can be pasted on another workflow page. Note: that any existing links will be broken.
Delete	Deletes the selected action(s) from the workflow page.
Properties	Opens the properties dialog box for the selected action.
Origin Contact Groups	Available for an action that has been defined as the terminus for a contact group. Select this option to view the Email groups or UC groups for which the action is defined as the terminus.

Action Menu Items	
Menu Item	Description
Set as Routine Entry Point	Available for actions that belong to a building block routine page. Select this option to set the action as the starting point for the routine. For more information on building blocks, refer to Chapter 5: Building Blocks.
Go to Target	Available for Connector Out actions. Select this option to jump to the corresponding Connector In. For more information on Connector Out and Connector In actions, refer to page 188.
Hide Incoming Links	Hides the incoming links for the selected action. For more information on Hiding Incoming Links on page 38. Note: Although multiple actions may be selected, links are only hidden for the action upon which you have right-clicked.

Forming Links Between Actions and Workflow Pages

Before workflow can be completed, links must be specified between actions. A link between actions tells workflow where to send contacts after they have passed through a specific action.

Links can also be formed between workflow pages, which may be required when the workflow becomes too large to fit on one workflow page.

It is recommended that you avoid crossing links and keep links straight. This makes it easier to understand and modify workflow in the future.

The sections that follow explain the methods of linking actions and workflow pages.

Forming Links between Actions

To be considered complete, most actions require one or more links to other actions. Actions must be completed before the page can be saved.

To draw links from one action to another:

1. Double-click the action that you would like to link to other actions. The properties dialog box opens.

The example below shows the properties dialog box for *Play Audio File*.

The screenshot shows the '37: Play Audio File' dialog box with the following settings:

- Action Name: Play Audio File (highlighted)
- Audio Message: (empty dropdown)
- Clear Digit Buffer
- Enable DTMF Abort
- Enable Playback Controls
- Speed: (disabled)
- DTMF Keys: Decrease: NONE, Reset: NONE, Increase: NONE
- Skip/Pause/Resume: Skip Period (ms): 5000, Skip Backward: NONE, Pause/Resume: NONE, Skip Forward: NONE
- Play To: Caller, Callee
- Go To: (dropdown menu)
- Link Name: (text field)
- On Play Failure Go To: (dropdown menu)
- Link Name: (text field)
- Hide Incoming Links
- Log Action
- Buttons: OK, Cancel

The *Go To* dropdown lists on the properties dialog box provides a list of other actions on the workflow page. Open the dropdown and select an action to create a link to that

action. Sometimes these fields have slightly different names, such as *If No Match Go To*, or *On Error Go To*.

The screenshot shows the 'Play Audio File' dialog box. At the top, the 'Action Name' is 'Play Audio File' and the 'Audio Message' is 'abc\Track1.wma'. There are checkboxes for 'Clear Digit Buffer' (unchecked) and 'Enable DTMF Abort' (checked). Below these are sections for 'Speed' and 'Skip/Pause/Resume' with various DTMF key settings. The 'Go To' dropdown is open, displaying a list of actions: '3 End Workflow Session', '1 Set Audio File Base Subdirectory', '3 End Workflow Session', and '5 Output Debug String'. The 'Link Name' field is empty.

2. Select the action with which you want to create a link from the first 'Go To' field.
3. Type a name in the 'Link Name' field if you want to label the link between these two actions.

The screenshot shows the 'Play Audio File' dialog box with the 'Go To' dropdown set to '3 End Workflow Session' and the 'Link Name' field containing the text 'Success'. The 'On Play Failure Go To' dropdown is set to '5 Output Debug String'. The 'Link Name' field is now populated with the text 'Success'.

4. The image below provides an example of a link that has been labelled.



5. Select additional links, as required by the action type.

For example, Play Audio File requires you to select a link to be followed in the event of a failure (e.g., the message fails to play because it is not recorded).

Action Name:
 Audio Message:
 Clear Digit Buffer Enable DTMF Abort
 Enable Playback Controls
 Speed
 DTMF Keys
 Decrease:
 Reset:
 Increase:
 Skip/Pause/Resume
 Skip Period (ms):
 DTMF Keys
 Skip Backward:
 Pause/Resume:
 Skip Forward:
 Go To: Link Name:
 On Play Failure Go To: Link Name:
 Hide Incoming Links Log Action

6. Type a name in the 'Link Name' field if you want to label the link between this action and the action selected in Step 4.
7. This field can be left blank if a label is not required, as shown for the red failure link below.

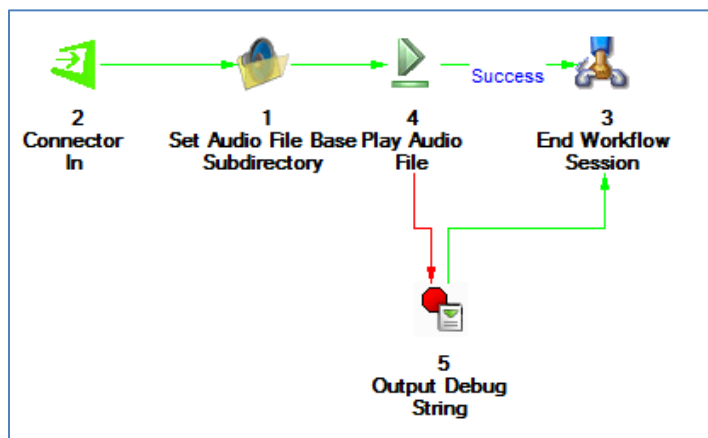

If you have completed all of the action's properties, click *Save*.

To continue completing the properties of the action, refer to the next section for general information on forming links between actions and workflow pages.

8. In this section, you have learned how to create links between actions. The section that follows explains how to hide inbound links for an action or group of actions.

Hiding Incoming Links

When forming links between actions, keep links straight and avoid crossing links. Straight, uncrossed links will make workflow easier to read. Sometimes a particular action has many incoming links, making it difficult to follow the workflow. The example below shows an action labelled *Transfer to Voice Mailbox*, which has many incoming links.

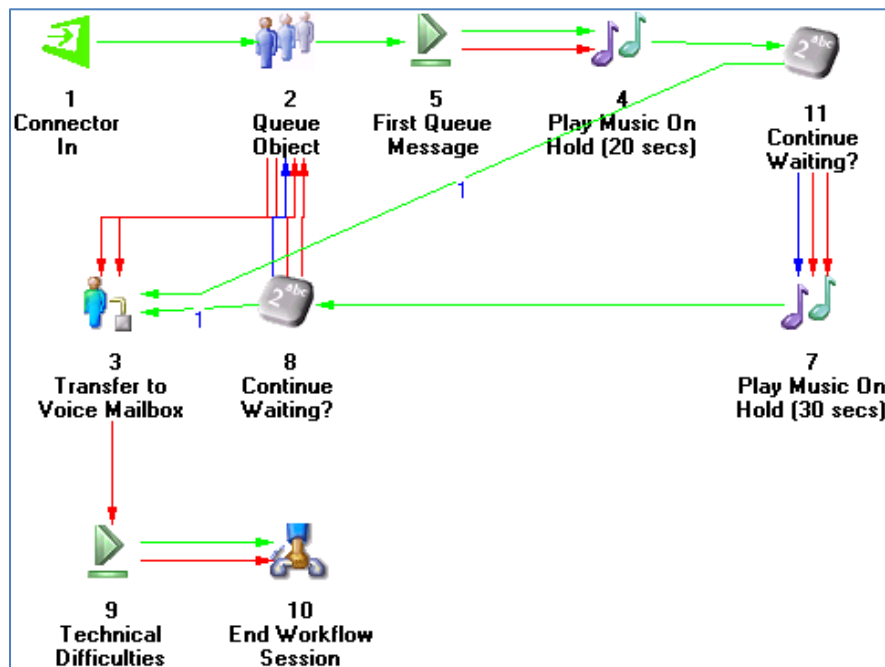

To hide the incoming links for a specific action:

1. Double-click on the action to view its properties.

38: Route Object

Action Name:

Object:

DN:

Go To Link Name

If DN Not Valid:

Hide Incoming Links
 Log Action

2. Check the 'Hide Incoming Links' checkbox to hide all of the links that terminate on this action.
3. Click OK to close the properties dialog box.

The incoming links are no longer displayed for this action.

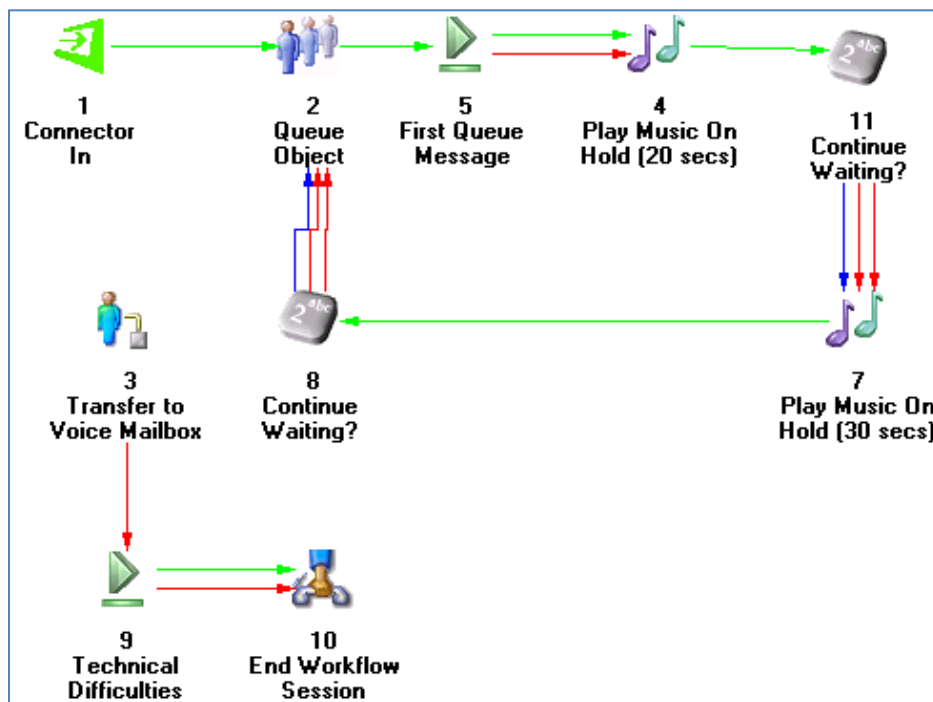

Note:

- You can also right-click an action and select 'Hide Incoming Links' from the menu that appears. A checkmark is displayed beside the menu option to indicate that it has been selected. To view hidden links, right-click the action, and click on 'Hide Incoming Links' in the menu so that the checkmark is removed.
- You can view hidden links by selecting the 'All Links' option in the iceAdministrator View menu. A checkmark is displayed beside the menu option to indicate that it has been selected. To remove the hidden links from view, select the 'All Links' option in the View menu again so that the checkmark is removed.

Using Link Router to Link Actions

Link Router facilitates the linking of other actions on a workflow page. Link Router helps to keep links straight. It is recommended that you use this when you are creating a workflow.

The properties dialog box for the Link Router action consists of a Go To dropdown list and a Hide Incoming Links checkbox. You can select an action to route to using the dropdown. This action does not affect the contact's experience in the workflow.

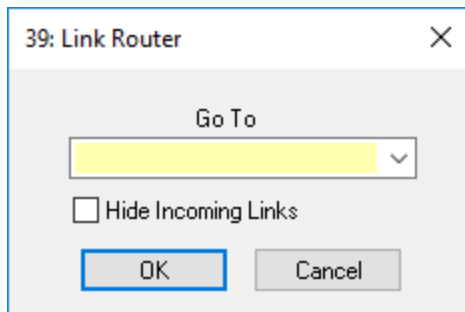

The image below shows two actions that are linked without using the Link Router action.

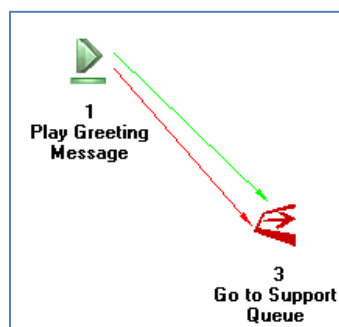

The links between these two actions can be manipulated using Link Router, which is represented on the workflow page by a green dot, as shown below.



For more information on Link Router, refer to page 227.

Forming Links between Pages

If the workflow you are designing becomes too large to fit on a single workflow page, you may decide to create a link to a second page. Links are formed between two pages with a Connector Out and a Connector In. Any pages within a switch can be linked. Connector Out and Connector In can also be used on the same workflow page to organize the workflow.

To link two workflow pages:

1. Navigate to the workflow page where you want to place a Connector In.
2. Click Connector In () on the Workflow Actions toolbar, and drop the connector onto the workflow page.

The properties dialog box opens for 'Connector In.'

40: Connector In

Action Name: Set Default

Connected To:

Graph	Page	Connector Out

Go to Connector Out

Go To Link Name

Hide Incoming Links
 Log Action

OK Cancel

- Select an action from the 'Go To' dropdown list.
All incoming contacts are directed to this action.
- Click *OK* to save your changes and close the properties dialog box.
- Navigate to the workflow page where you want to place a Connector Out.
The workflow from this page can be linked to the Connector In that you just created.
- Click Connector Out () on the Workflow Actions toolbar, and drop the connector onto the workflow page.

The properties dialog box opens for the Connector Out action.

41: Connector Out

Action Name: Set Default

Connect To

Graph:

Page:

Connector In:

Go to Target

Hide Incoming Links
 Log Action

OK Cancel

- Select the appropriate graph from the 'Graph' dropdown list.

- The graph that you select should contain the workflow page to which you wish to direct contacts.
8. Select the appropriate page from the 'Page' dropdown list.
Only the pages belonging to the graph you selected are listed.
 9. Select the appropriate connector from the 'Connector In' dropdown list.
Only the Connector In actions on the workflow page you selected will be listed. Contacts are directed to the selected Connector In. To complete the Connector Out, at least one Connector In must already be added to the destination page.
If you want to verify the location of the Connector In, click *Go to Target* to jump to the Connector In that you selected.
 10. Click *OK* to close the properties dialog box.
 11. From the File menu, choose 'Save.' (To cancel the save operation, click *Cancel* on the 'Progress' dialog box.)

Logging Activity for an Action

Each action has a *Log Action* checkbox. When *Log Action* is enabled, you can retrieve details about activity for the action from iceReporting. For example, reports can show the number of contacts that have passed through an action. For more information on reports, refer to the *iceReporting User Manual*.

To enable logging for an action:

1. Double-click the action for which you would like to enable logging. The properties dialog box opens for the selected action.

The image below shows the properties dialog box for End Workflow Session.

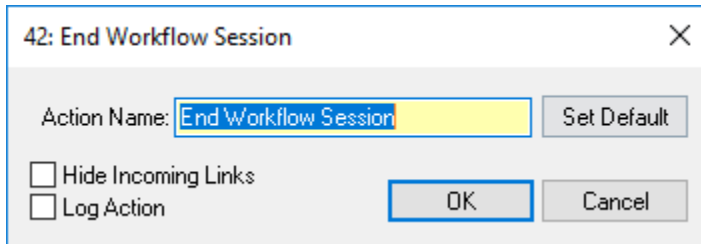

2. Check the 'Log Action' box on the properties dialog box.
3. Click *OK* to close the properties dialog box.
4. From the File menu, choose 'Save.' (To cancel the save operation, click *Cancel* on the 'Progress' dialog box.)

Defining the Starting Point

Before contacts can move through the workflow you created, an action must be defined as the starting point. Defining a starting point involves selecting a **terminus** for a contact group. The terminus points to a specific workflow graph, page, and action. For example, if the terminus for a UC group is *Wait for Incoming Call*, every call that arrives in that UC group is presented to the *Wait for Incoming Call* action. The call will then go through workflow as it has been designed.

Caution: It is highly recommended to test workflow for voice calls after defining the starting point. To test new workflow, add an Assign DN action that points to the start of the workflow. Using iceBar, you may dial the number specified in the Assign DN action. The types of tests that you conduct depend on the workflow you have created. As a general rule, you should test the following scenarios:

- When a user is available
- When a user is unavailable (i.e., when the caller is queued)
- When the queue is in night mode (i.e., when no users are logged on)
- When your contact center is closed (i.e., it is outside of hours of operation)
- Valid menu options
- Invalid menu options

To define the terminus:

1. Navigate to the contact group (Email or UC) for which you want to define the terminus.
2. If you selected Email Groups, notice the 'Terminus' section that is part of the properties page.

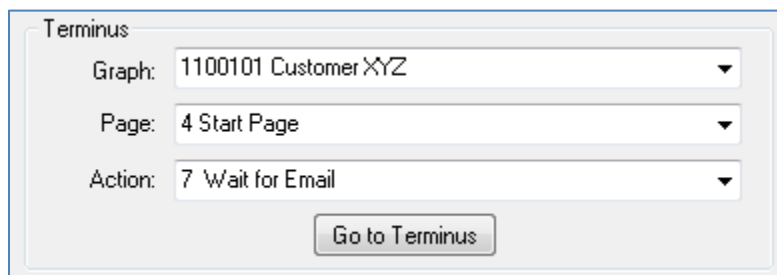

Terminus

Graph: 1100101 Customer XYZ

Page: 4 Start Page

Action: 7 Wait for Email

Go to Terminus

3. If you selected UC Groups, notice the 'AV Terminus' section.

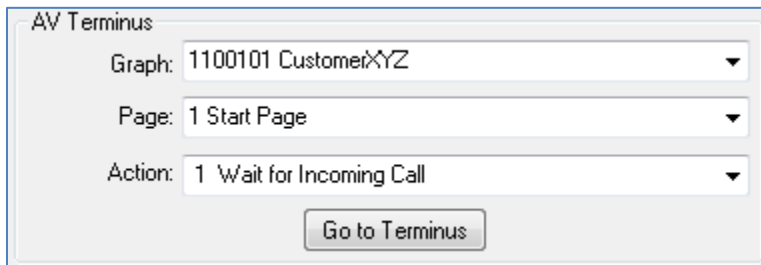

The screenshot shows a configuration window titled "AV Terminus". It contains three dropdown menus: "Graph" with the value "1100101 CustomerXYZ", "Page" with the value "1 Start Page", and "Action" with the value "1 Wait for Incoming Call". Below the dropdowns is a button labeled "Go to Terminus".

4. Select the appropriate workflow graph from the 'Graph' dropdown list.

The graph that you select should contain the workflow page to which you wish to direct contacts.

5. Select the appropriate workflow page from the 'Page' dropdown list.

Only the pages belonging to the graph you selected are listed.

6. Select the appropriate action from the 'Action' dropdown list.

Only the actions on the workflow page you selected are listed.

Contacts that arrive on this contact group are directed to the selected action. The action that you select as the terminus is highlighted in yellow on the workflow page. The example below shows the AV terminus as defined in the UC Group pictured at step 1.

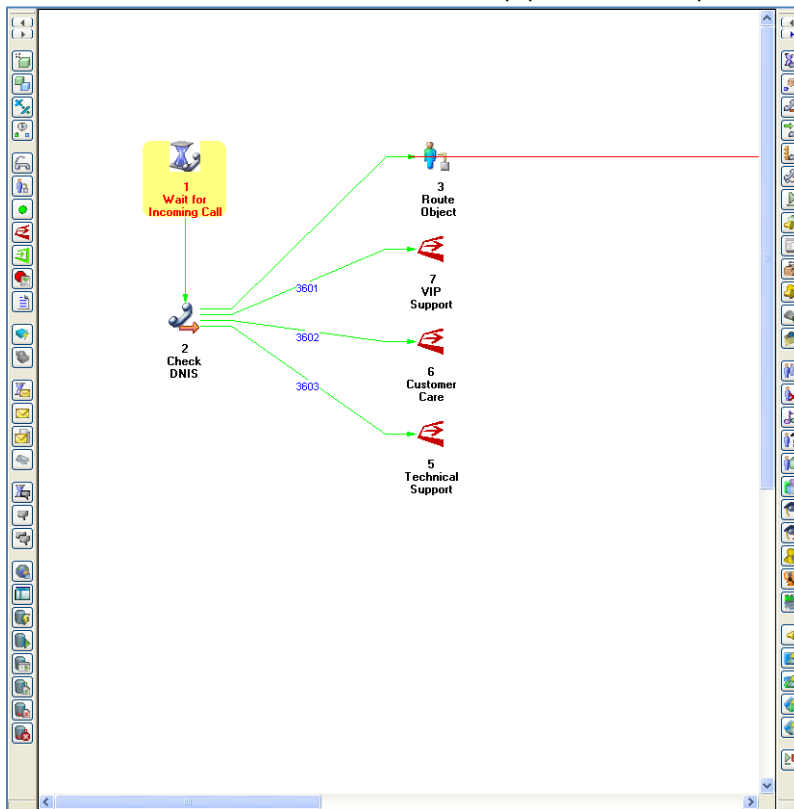

For more information on contact groups, refer to the *iceAdministrator User Manual*.

Moving Actions on a Workflow Page

When modifying or creating a workflow, you may wish to reorganize actions on a workflow page. Dragging and dropping actions to a new location allows you to create more space for new actions, or to simply change the layout of the existing actions.

To move an action on the workflow page:

1. Navigate to the appropriate workflow page to view the existing actions and links.

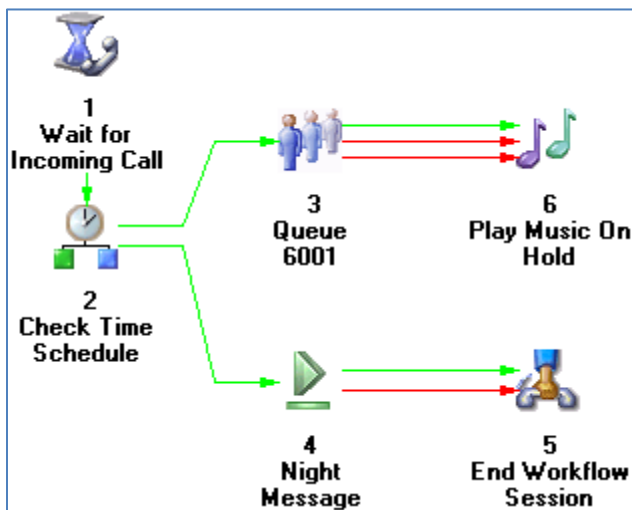

2. Click on the action you want to move. While holding the mouse button down, drag the icon to a new part of the workflow page and release the mouse button.

The screenshot below shows that *Wait for Incoming Call* has been moved to a new location and that the link between *Wait for Incoming Call* and *Check Time Schedule* is automatically redrawn.

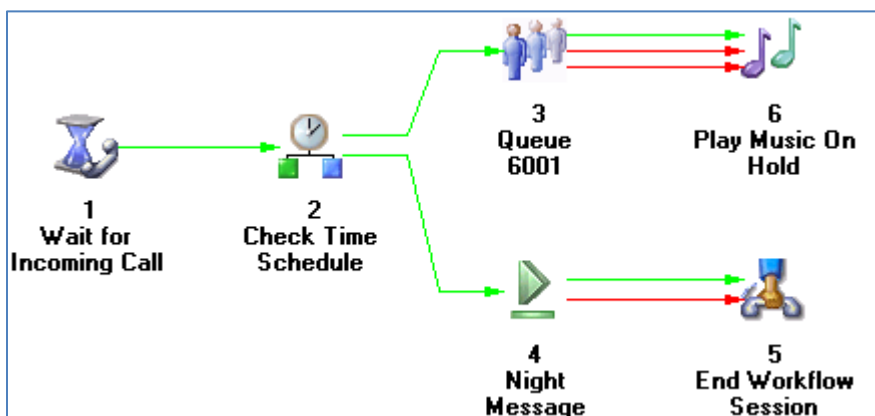

Aligning Actions on a Workflow Page

To align an action with another action:

1. Navigate to the appropriate workflow page to view the existing actions and links.
2. Hold your left mouse button down and use your mouse to draw a line around the actions you wish to align.

In the image below, the three actions are not in line with one another. All three have been selected.

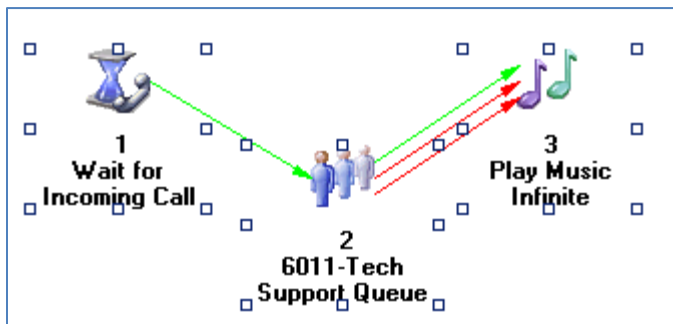

3. From the Layout menu, choose 'Align.'

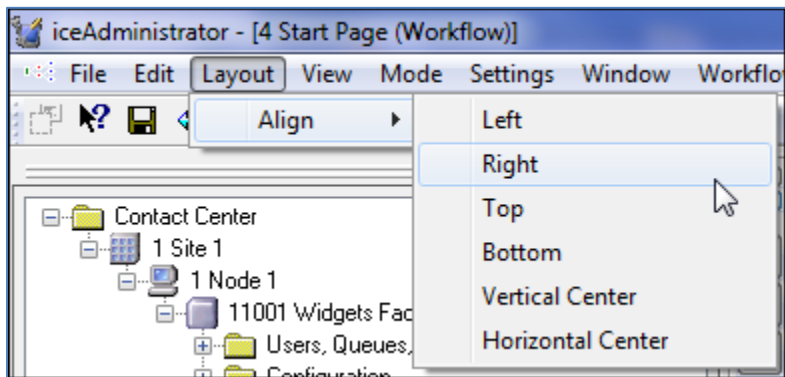

4. The following options are available for aligning actions: Left, Right, Top, Bottom, Vertical, Horizontal.
5. Select the appropriate alignment option.

In the example below, the 'Vertical' option was selected. The three actions are now aligned.

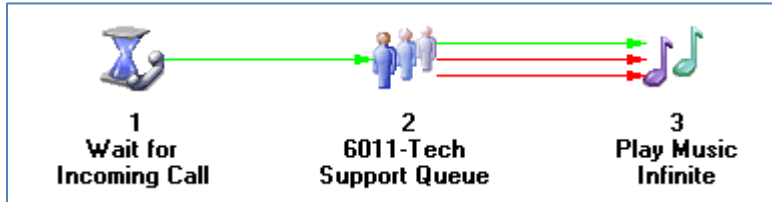

Copy/Cut and Paste Actions

When modifying the workflow, you may wish to copy an action within a workflow page or copy an action to another workflow page. Copying actions will allow you to duplicate workflow you have already created. Cutting actions allows you to move actions to a new location.

Caution: It is highly recommended that you modify workflow outside of regular hours or peak hours. Place a test call or send a test email or IM message (as required) to your contact center after changes are saved to ensure that workflow is functioning properly.

To copy or cut an action:

1. Navigate to the appropriate workflow page to view the existing actions and links.
2. Right-click on the action you want to copy or cut.

A menu appears.

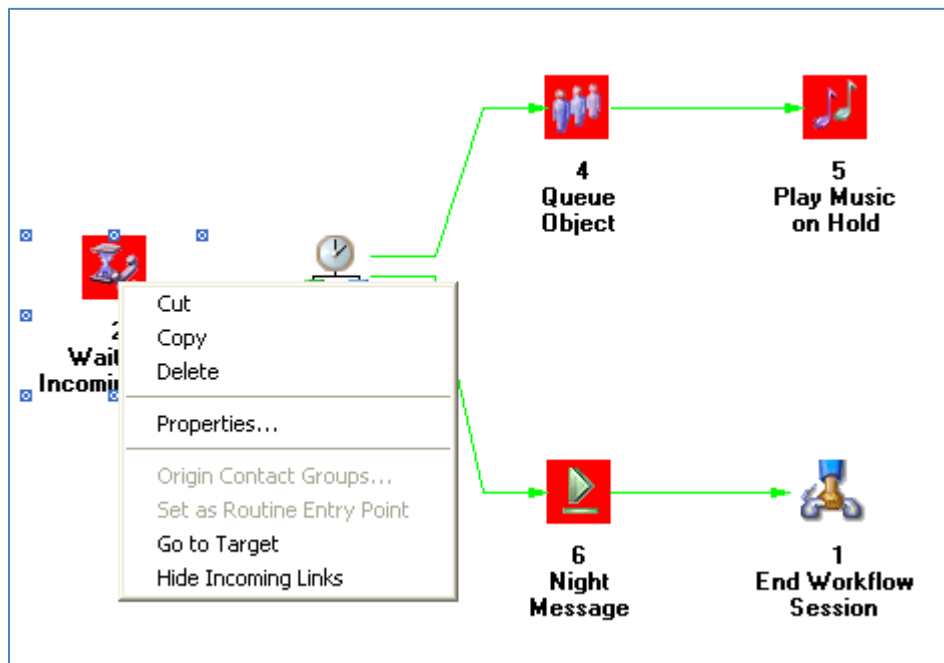

3. Select 'Cut' or 'Copy' from the menu.
4. Navigate to the location where you want to paste the action.
This could be another position on the same workflow page or a different workflow page.
5. Right-click on a blank portion of the page and select the 'Paste' option that appears.
The action is pasted in the new location.

Note:

- You can follow the steps above to copy or cut multiple actions. Use your mouse to draw a line around the actions you wish to copy or cut. When you get to Step 2, you can right-click on any of the selected actions. All of the selected actions are copied or cut and pasted by following the rest of the steps above.
- After you have cut or copied actions, some actions may have a red background. These actions require some properties to be completed (e.g., new links to other actions).

It is recommended that you verify the properties of all pasted actions to ensure that they make sense in the workflow.

Moving Links

Links tell workflow where to send contacts after they have passed through a specific action. Changing the properties for each action can modify links, as described in *Forming Links Between Actions and Workflow Pages* on page 34. Alternatively, you can drag and drop the links as described below.

Caution: It is highly recommended to modify workflow outside of regular or peak hours. Place a test call or send a test email or IM (as required) to your contact center after changes are saved to ensure that workflow is functioning properly.

To modify links from one action to another:

1. Navigate to the appropriate workflow page to view existing actions and links.
2. Click on the link that you want to move.

Notice the selection markers that appear along the link when it is selected. The example below shows that the link between *Wait for Incoming Call* and *Check Time Schedule* has been selected.

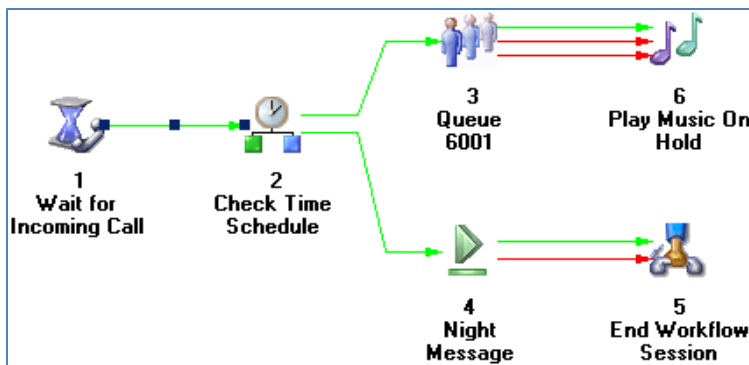

3. Position your mouse directly over the marker that is closest to the pointer on the link.



4. Click on the marker and drag the link to the new action.

- The link must be directly over the icon when you release the mouse button. The example below shows that Wait for Incoming Call is now linked to Queue 6001.

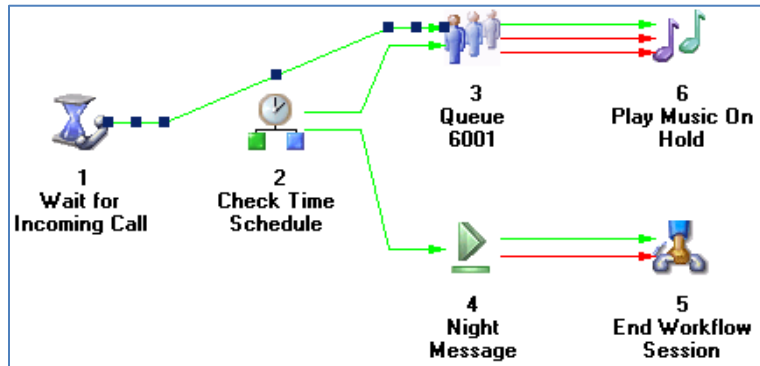

Note: Links between actions are automatically drawn. When you change the shape of the link between two actions, the new shape does not get saved to the database. The link returns to its original state when you reload the workflow.

Adding an Action to Workflow

When the needs of your contact center change, it may be necessary to add a new action into the existing workflow. Adding a new action to workflow involves placing the action on the workflow page and ensuring that it is linked to other actions.

Caution: It is highly recommended to modify workflow outside of regular hours or peak hours. Place a test call or send a test email or IM message (as required) to your contact center after changes are saved to ensure that workflow is functioning properly.

To add an action to the workflow:

1. Navigate to the appropriate workflow page to view existing actions and links.
2. From the Workflow Actions toolbar that borders either side of the workflow page, click on the action you want to use and drag it onto the workflow page.

The action is placed on the workflow page, and the properties dialog box for the action automatically opens. The screenshot below shows the properties dialog box for Route Object.

38: Route Object

Action Name:

Object:

DN:

Go To Link Name

If DN Not Valid:

Hide Incoming Links

Log Action

Note:

- If you are not sure which button represents the action you wish to add, hold your mouse pointer over the button until a tool tip appears with the name of the action. For a description of each action, refer to page 155.
 - Notice the *Action Name* field that is part of the properties dialog box. By default, the name of the action is automatically entered into this field.
3. Click OK to close the properties dialog box.

The properties dialog box closes.

- The new action is displayed with a red background because its properties are incomplete.

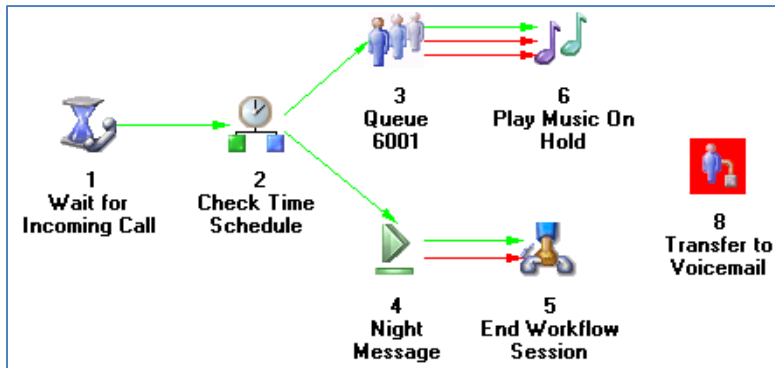

- Complete the properties of the new action.
- When the action's properties are complete, the red background disappears, and links are drawn to other actions. For more information on completing an action's properties, refer to Chapter 6: Standard Actions and Chapter 7: Advanced Actions.

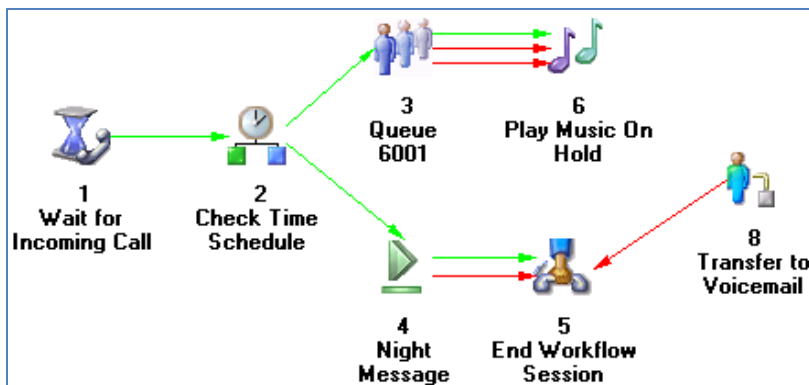

- Draw links from other actions to the new action.

The Route Object action named *Transfer to Voicemail* shown in the above example will not receive any contacts because it is not linked to the rest of workflow. (To be certain that there are no incoming links, make sure the *Hide Incoming Links* option is not enabled for the action). The action must have at least one inbound link before it is used within the workflow. The image below shows that *Play Audio File* (Night Message) has been modified to direct calls to *Route Object* (Transfer to Voicemail).

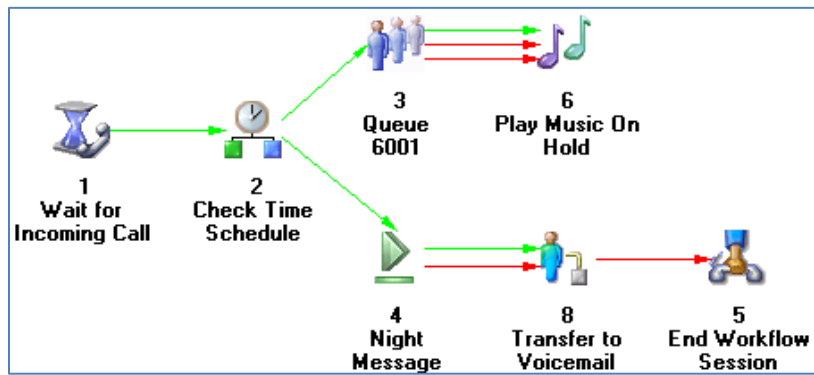

Deleting Actions

Before an action is deleted from the workflow, you should remove all incoming links so that this action is no longer required within the workflow application.

Caution: It is highly recommended to modify workflow outside of regular or peak hours. Place a test call or send a test email or IM (as required) to your contact center after changes are saved to ensure that workflow is functioning properly.

To delete an action:

1. Navigate to the appropriate workflow page to view the actions that you wish to delete.
2. Ensure that all incoming links have been redirected.
3. Right-click on the action you want to delete.

A menu appears.

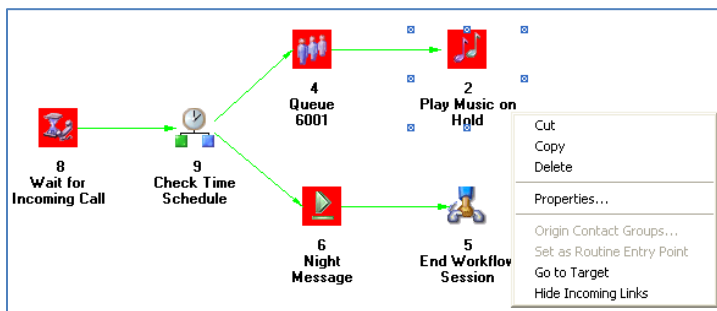

4. Select 'Delete' from the menu.

A message box appears to confirm the removal of the action.

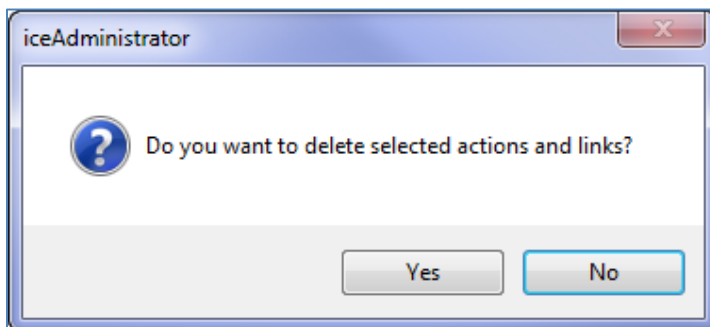

5. Click Yes to delete the action.

The action is removed from the workflow page. Clicking *No* cancels the deletion.

Note: You can follow the steps above to delete multiple actions. Instead of clicking on a single action in Step 2, use your mouse to draw a box around the actions you wish to delete. Follow the steps above to delete all of the selected actions.

After you have deleted actions, some remaining actions may have a red background. These actions may require new links to other actions. If you had imported the workflow, actions that are no longer supported will have red backgrounds. To save your work, you will have to remove all unsupported actions. You may also wish to validate your work. For more information on validating, refer to [Validating Workflow](#) on page 63.

Deleting a Workflow Page

If a workflow page is no longer required, it can be deleted. Before deleting the workflow page, ensure that none of its workflow pages are used by your contact center.

Caution: It is highly recommended to modify workflow outside of regular hours or peak hours. Place a test call or send a test email or IM message (as required) to your contact center after changes are saved to ensure that workflow is functioning properly.

To delete a workflow page:

1. Navigate to the workflow page that you wish to delete and right-click.

A menu appears.

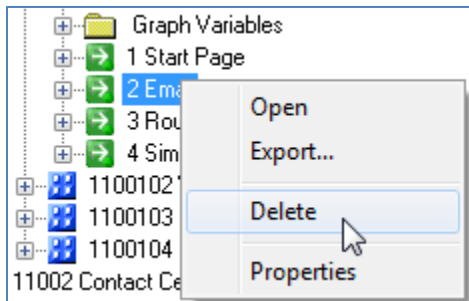

2. Select 'Delete' from the menu. The page is automatically deleted. No confirmation message will appear.

In this section, you have learned how to delete a page from a workflow graph. The next section explains how to delete a workflow graph that is no longer required.

Deleting a Workflow Graph

If a workflow graph is no longer required, it can be deleted. Before deleting the workflow graph, ensure that none of its workflow pages are used by your contact center.

Caution: It is highly recommended to modify workflow outside of regular or peak hours. Place a test call or send a test email or IM (as required) to your contact center after changes are saved to ensure that workflow is functioning properly.

To delete a workflow graph:

1. Navigate to the workflow graph that you wish to delete and right-click on it.

A menu appears.

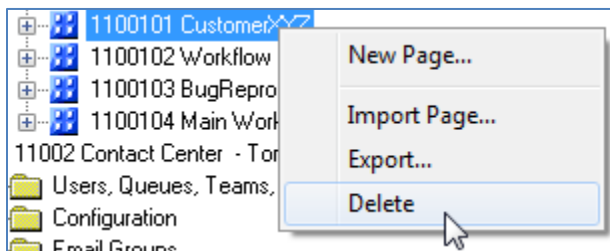

2. Select 'Delete' from the menu.

A message box appears to confirm the removal of the workflow graph.

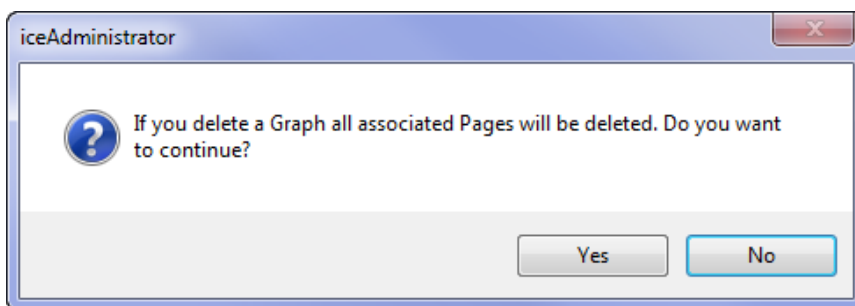

3. Click Yes to delete the workflow graph.

The graph is removed from the Workflow folder in the tree view. Clicking No cancels the deletion.

Emptying the Workflow Folder

You may decide to delete all workflow to avoid conflict messages when importing workflow. When you delete all workflow, you also delete audio messages, holidays, variables, and all workflow graphs.

Caution: It is highly recommended to modify workflow outside of regular hours or peak hours. Place a test call or send a test email or IM message (as required) to your contact center after changes are saved to ensure that workflow is functioning properly.

To delete all workflow:

1. Right-click on the Workflow folder.

A menu appears.

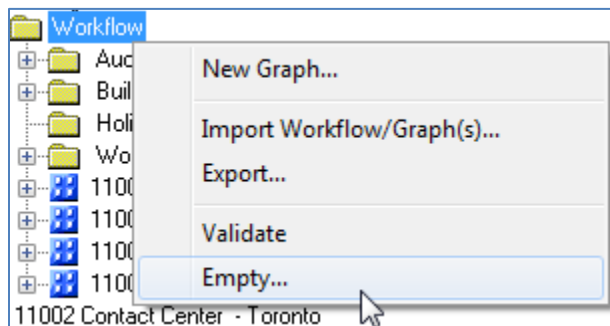

2. Select 'Empty' from the menu.

A message box appears.

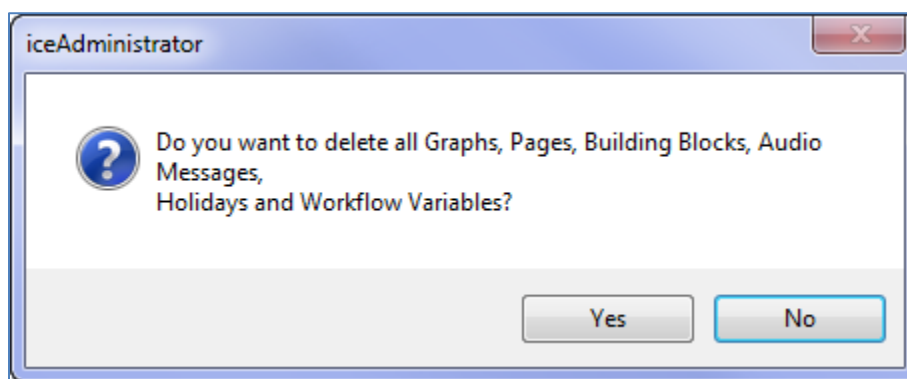

3. Click Yes to delete all of the workflows. Click No to cancel the deletion.
4. From the File menu, choose 'Save.' (To cancel the save operation, click *Cancel* on the 'Progress' dialog box.)

Validating Workflow

Whenever you save your changes to workflow, iceAdministrator first checks the integrity of your work. If there are no errors, your changes are saved to the database.

You can run this integrity test without saving your workflow using the 'Validate' feature. This allows you to check the workflow and can also be used when you are working offline.

To validate workflow:

1. Right-click on the 'Workflow' folder.

A menu appears.

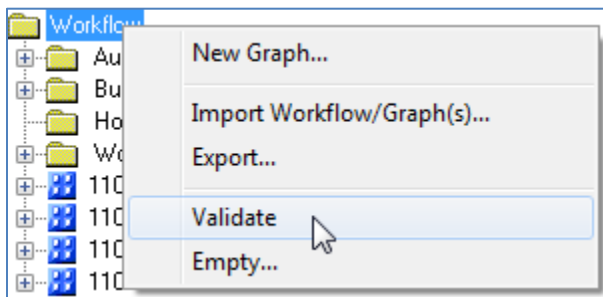

2. Select 'Validate' from the menu.
3. You can also select 'Validate' from the File menu. If an error in your unsaved data is detected, a message box appears, prompting you to complete or change the relevant data. Once you fix the first error, you can validate workflow again. iceAdministrator finds the next error and prompts you to fix it. This continues until all errors have been fixed. For example, the image below shows the message that appears when the properties of a workflow action have not been properly set.

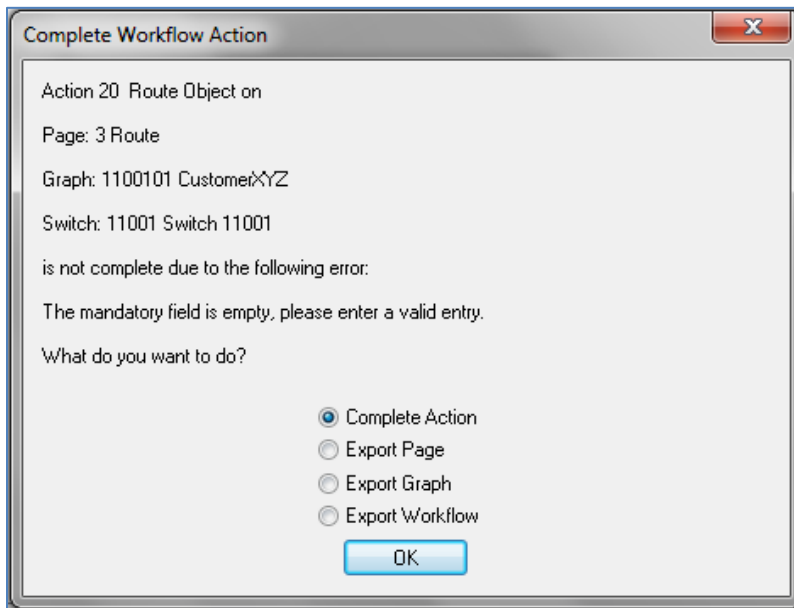

4. You are given the option of completing the action or of exporting the workflow to a file. If you select the 'Complete Action' radio button and click *OK*, the workflow page containing the error opens.
5. If you validate workflow and you have no errors, a message box appears.

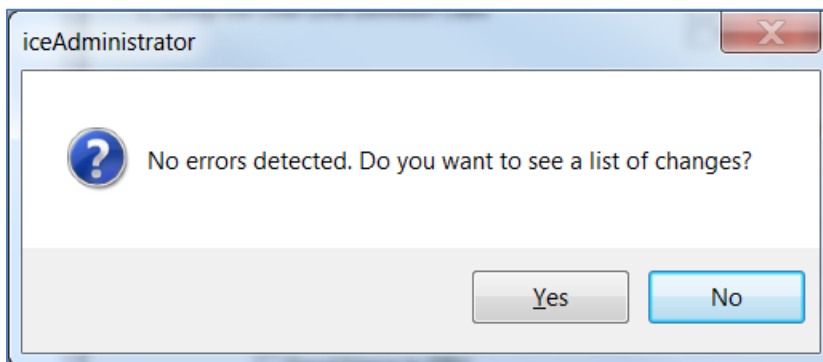

6. Click *Yes* to see the 'Show Modified Items' dialog box, or click *No* if you do not want to see it.

7. The 'Show Modified Items' dialog box below shows the list of modified items in the workflow. The modified items in the tree are displayed in a different font colour.

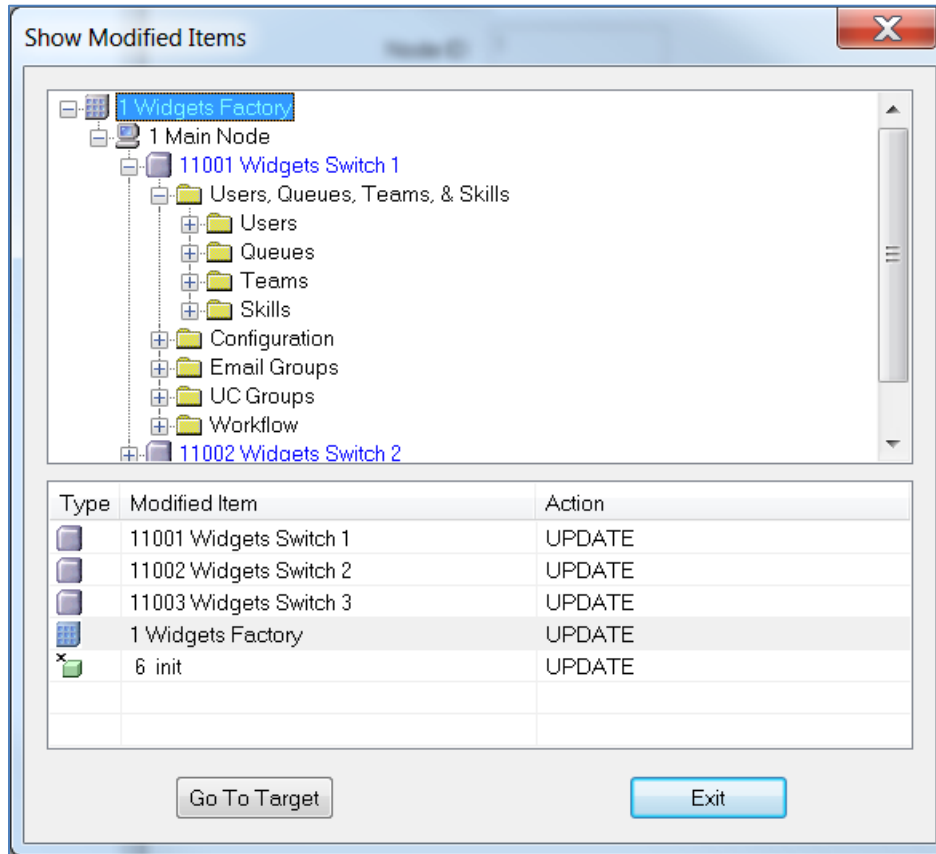



Chapter 2: Audio Messages

Audio messages are used in the workflow to prompt callers for information, play information to callers, and play information to users.

Creating audio messages is a two-step process:

- First, an audio message should be added to iceAdministrator, as described on page 75.
- Second, an audio message in iceAdministrator should be recorded before it is enabled in the workflow. If an audio message that has not been recorded is enabled in an action, the action will fail. You can record audio messages by calling System Administration, as described on page 90.

The sections that follow describe how to create, record, and delete audio messages.

Viewing Audio Messages

Audio messages can be viewed in the Audio Messages folder. If your contact center has many audio messages, the list that appears when you open the Audio Messages folder can be quite long. To better organize this list, you can move messages into Audio Message groups, which can be added to the Audio Messages folder.

Each audio message can be expanded in the tree view to display the different versions of the message that your contact center is using. Some call centers use only one message – the 'Default' version. Your contact center may need another version of the same message depending on the workflow application. For example, an English and French version of the same message may be required. Workflow can be configured to use either message depending on the language selected by the caller. If workflow does not specify which version of the message to use, the one that is named 'Default' is used.

To view audio messages:

1. Double-click the Workflow folder.

The Audio Message folder is displayed along with Building Blocks, Holidays, Variables, and workflow graphs.

An Audio Message folder can also be viewed by expanding a building block. Audio messages that have been created within a building block are not accessible outside of the building block. For more information, refer to Building Block Audio Messages on page 133.

2. Double-click the Audio Message folder in the tree view.

Existing audio messages and audio message groups are displayed.

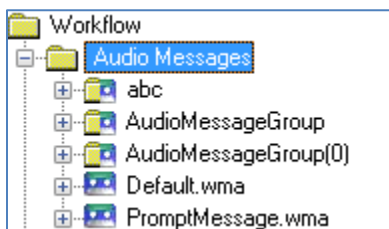

3. Highlight the audio message for which you would like to see more information. If the audio message is in a group, you must first double-click the audio message group in order to see the audio messages in that group.

- To see the actual message properties, double-click on the audio message in the tree view to see the 'Default' version and/or any other versions that have been added to base subdirectories. Base subdirectories organize different sets of messages as required by workflow applications.

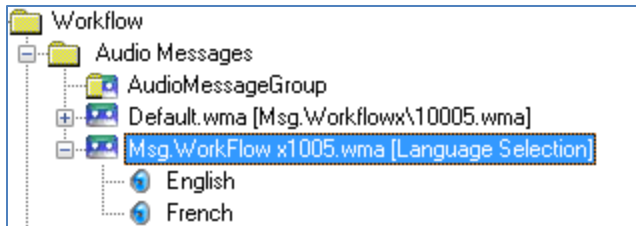

- Click on the base subdirectory folder of your choice.

For example, the screenshot below shows the properties for a message in the default base subdirectory.

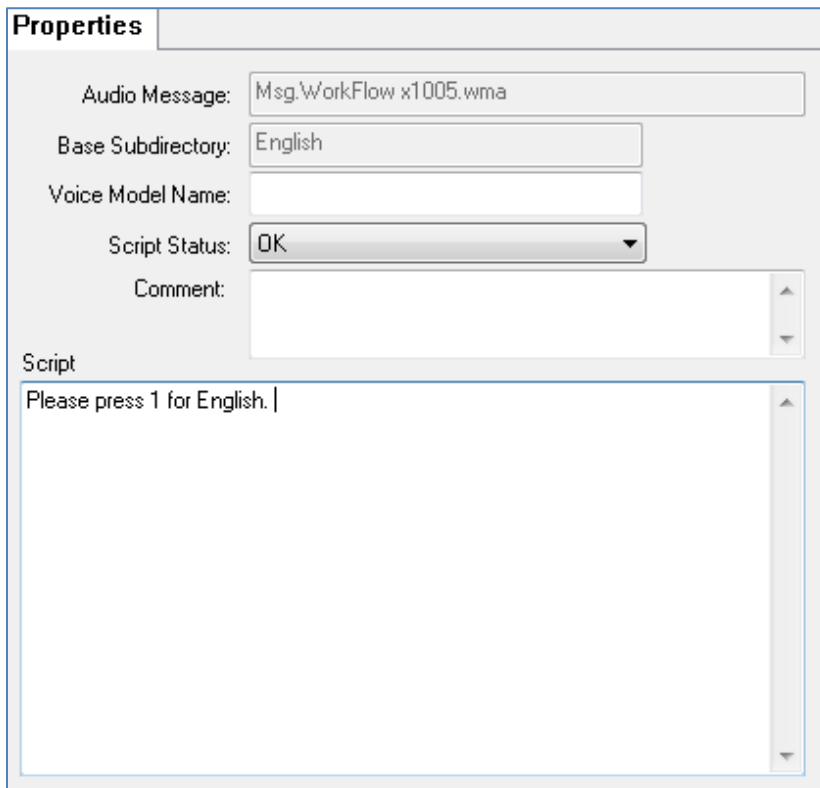

- The properties for both the audio message and its variations stored in base subdirectories are explained in the sections that follow. Although many of these fields do not require completion, information that is filled out can be tracked, and results can be presented with iceReporting. This will help maintain records for your audio messages.

General Audio Message Properties

When you click on an audio message, you can view the general audio message properties in the detail view, as described in the table below.

Audio Message Properties	
Property	Description
Path	The relative path of the audio message. This field displays the audio message group(s) to which the audio message belongs.
File Name	<p>The standard naming convention for audio messages is a five-digit number (e.g., 75008.wma, but audio message file names can be alphanumeric and up to 256 characters in length. The file name will appear in action property dropdown lists.</p> <p>By default, any name you enter here will appear on the corresponding audio message file on the ice server, in the following directory: c:\ice\voice\<switch number>.<="" p=""> <p>By default, audio messages in a building block are stored in the base directory c:\ice\voice\<switch @buildingblock:basedir.<="" a="" base="" bblock\<buildingblockname>\<base="" called="" directory="" exact="" in="" is="" name="" number>="" of="" p="" stored="" subdirectory>.="" system="" the="" variable=""> <p>An absolute path can be entered if you want to create a message that is not located in the default directory.</p> </switch></p></switch></p>
Description	A description of the message (e.g., Office Closed). The description appears to the right of the file name in action property dropdown lists.

Specific Audio Message Properties

When you expand an audio message in the tree view, you can click on a specific version of the message to view the specific audio message properties, as described in the table below.

Base Subdirectory Properties	
Property	Description
Base Subdirectory	<p>Base subdirectories are used in workflow applications that require a particular set of messages. For example, one application might require both English and French messages. In this case, two subdirectories need to be created. If only one message is required, it is stored in the default base subdirectory. The messages in a base subdirectory are stored in c:\ice\voice\<switch number="">\<base subdirectory>.</switch></p> <p>Note: The messages in a base subdirectory of a building block are stored in c:\ice\voice\<switch bblock\<buildingblockname>\<base="" number>="" p="" subdirectory>.<=""> <p>Each base subdirectory that you select for a given audio message displays unique message details in the detail view. For example, if you select 'English,' details for the English message are shown. If you select 'French,' details for the French message are shown.</p> <p>Base subdirectories apply only to messages with a relative path (e.g., messages that are stored in the default directory).</p> </switch></p>
Voice Model Name	<p>The name of the person who has recorded the audio message. You can use this field to verify that the same person records all related messages.</p>
Script Status	<p>A dropdown list showing the script status. The available options are:</p> <ul style="list-style-type: none"> Not Recorded OK Re-record Re-script <p>This status must be manually changed.</p>
Comment	<p>Additional notes about the audio message. This field is optional.</p>
Script	<p>The text of the audio message.</p>

Adding an Audio Message Group

If you have many audio messages, you can organize them using Audio Message groups. Once you have created an audio message group, you can create sub-folders within it.

Caution: Workflow looks for audio messages in a specific directory. If you add messages to a new audio message group, the workflow may not be able to play those messages, if the directory is not updated.

To create a new audio message group:

1. Right-click on the Audio Messages folder in the Tree view.

A menu appears.

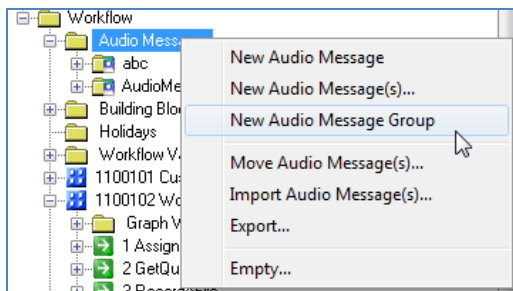

2. Select 'New Audio Message Group' from the menu.

The 'Properties' page for the audio message group appears.

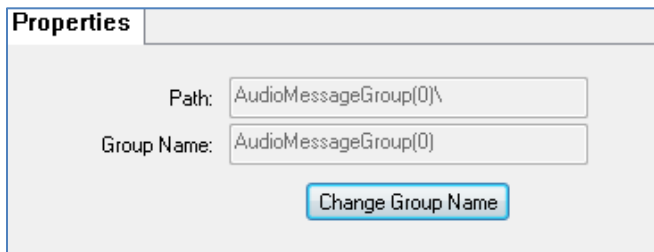

3. If you want to modify the audio message group name, click *Change Group Name*.

A dialog box appears.

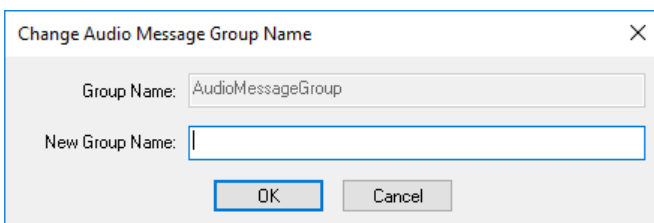

4. Enter a name for the audio message group in the 'New Group Name' field.
5. Click *OK* to close the window.
6. The audio message group name and path are updated based on the new group name.
7. From the File menu, choose 'Save.' (To cancel the save operation, click *Cancel* on the 'Progress' dialog box.)

You can create sub-folders in Audio Message groups. Right-click on the desired Audio Message Group folder in the tree view, and follow steps 2 to 6 above.

Adding an Audio Message

You might need to add a new audio message if you are making changes to workflow or if you want to enable a new audio message in the workflow. Before you can record a message, you create the message in the Audio Messages folder.

Adding a New Audio Message

To add a new audio message to the tree view:

1. Right-click on the Audio Messages folder or a particular Audio Messages Group folder in the tree view.

A menu appears.

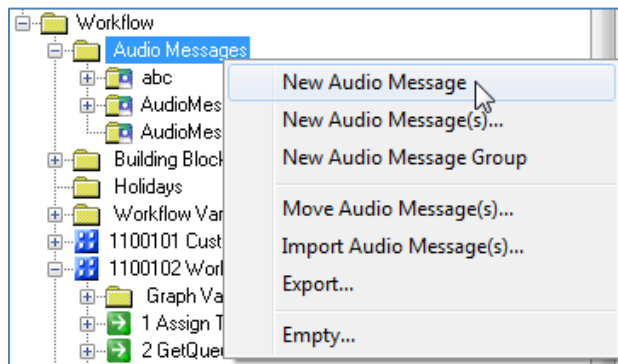

2. Select 'New Audio Message' from the menu.
3. Two tabs appear on the right side of the iceAdministrator window with the 'Properties' page displayed on top. The 'Path' field displays the name(s) of any groups and sub-groups to which the audio message belongs.

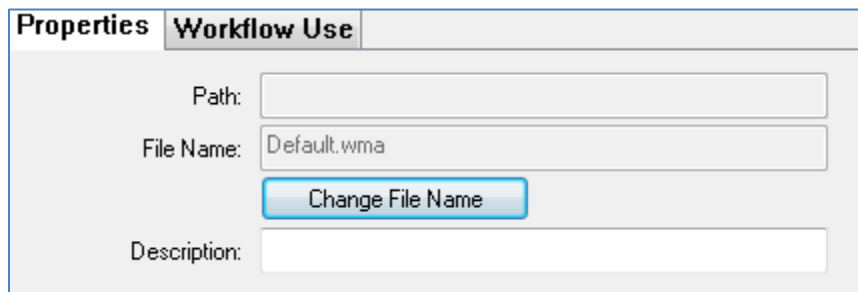
A screenshot of the 'Properties' dialog box for a new audio message. The dialog has two tabs: 'Properties' and 'Workflow Use'. The 'Properties' tab is active. It contains three fields: 'Path:' (empty), 'File Name:' (containing 'Default.wma'), and 'Description:' (empty). Below the 'File Name' field is a 'Change File Name' button.

You can change the name of the audio message file, and enter a description. The default File Name is Default.wma. You can change the name to the standard naming convention,

which consists of 5 numbers (e.g., 75008.wma or an alphanumeric name that is up to 256 characters.

4. From the File menu, choose 'Save.' (To cancel the save operation, click *Cancel* on the 'Progress' dialog box.)

As mentioned before, there can be different versions of each audio message, such as an English version and a French version. The properties for each message variation can be found in the base subdirectories of the audio message. When you create a new audio message, a default base subdirectory is automatically created.

5. To see the 'Properties' page for the default base subdirectory, double-click on the newly created audio message in the tree view. Double-click on the 'DEFAULT' folder. The properties for the base subdirectory are displayed in the detail view, where details like the message text can be entered.

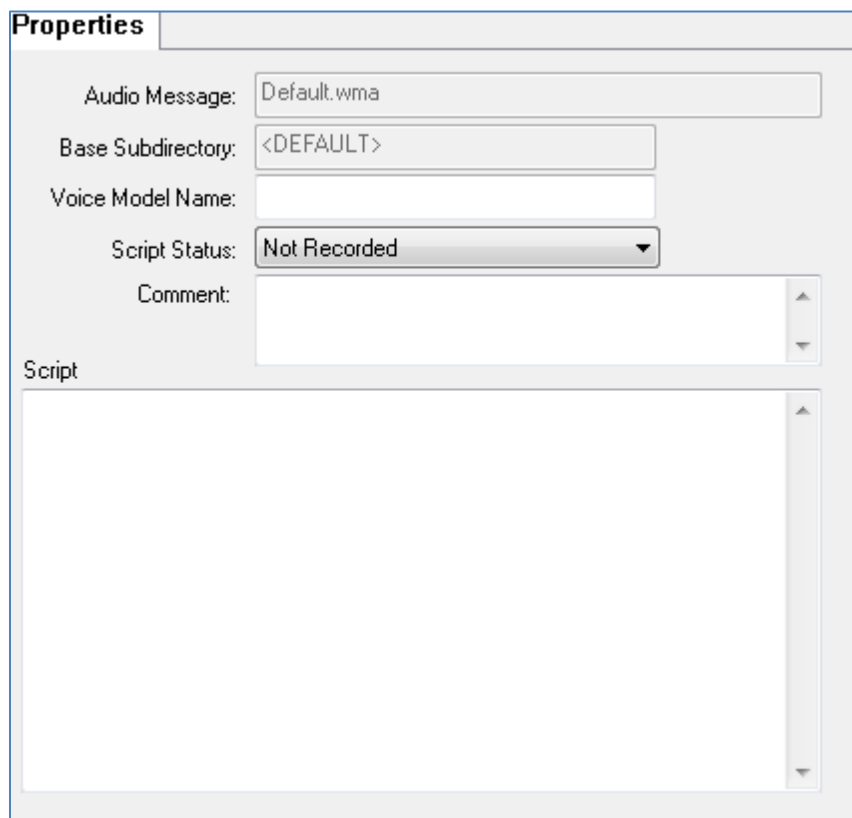

The screenshot shows a 'Properties' dialog box with the following fields and controls:

- Audio Message:** Text box containing 'Default.wma'
- Base Subdirectory:** Text box containing '<DEFAULT>'
- Voice Model Name:** Empty text box
- Script Status:** Dropdown menu with 'Not Recorded' selected
- Comment:** Text area with a vertical scrollbar
- Script:** Large text area with a vertical scrollbar

6. This section has explained how to add an audio message with iceAdministrator's default properties. For more information on audio message properties, refer to the 'Audio Message Properties' tables in General Audio Message Properties on page 71 and Specific Audio Message Properties on page 71.

Adding Multiple Audio Messages

iceAdministrator allows you to create multiple audio messages simultaneously.

- You can add audio messages based on the default audio message properties.
- You can add audio messages based on an existing audio message's configuration – a template. This feature is helpful if you want to create new messages that have the same properties as existing messages.

To add multiple audio messages to the tree view:

1. Right-click on the Audio Messages folder in the tree view.

If you want to add multiple audio messages to a specific group, right-click on the audio message group.

A menu appears.

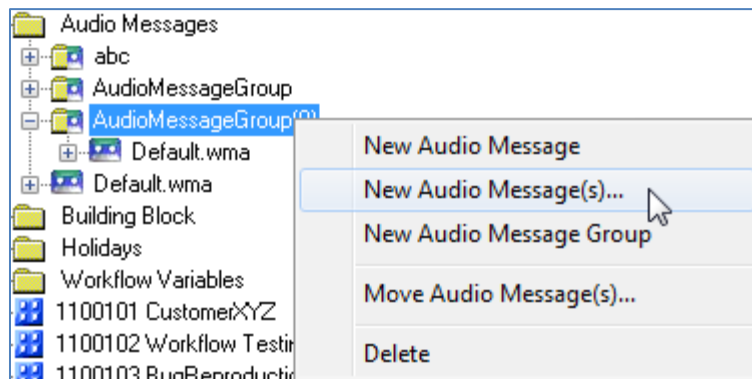

2. Select 'New Audio Message(s)' from the menu.

If you have any windows open in the detail view of iceAdministrator, a message box containing the following message appears.

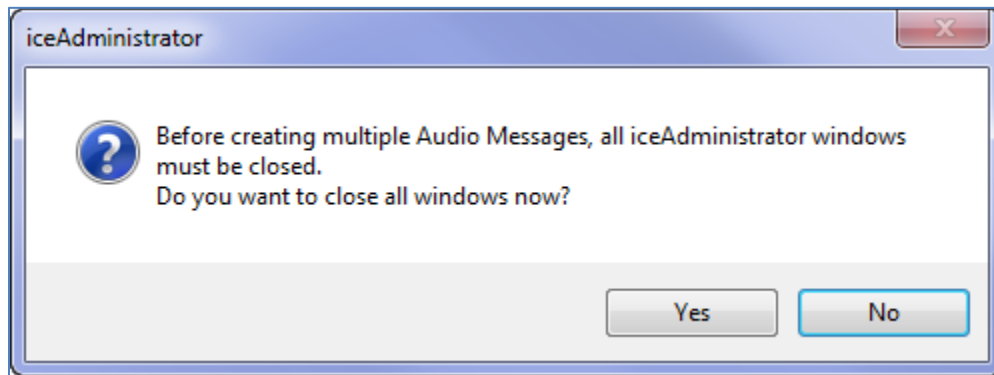

3. Click *Yes* to continue. Click *No* to cancel the process.

The following popup appears.

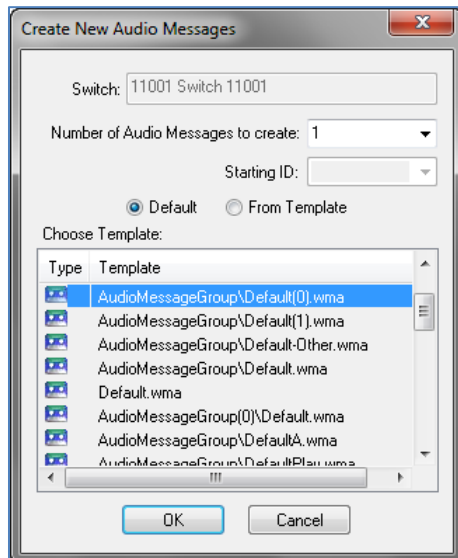

4. Select the number of audio messages you wish to create from the 'Number of Audio Messages to create' dropdown list.
5. Select the 'Default' radio button if you would like to create multiple audio messages based on iceAdministrator's default properties for an audio message. Select 'From Template' if you would like to use an existing audio message as a template.

When the 'From Template' radio button is selected, you can choose an audio message in the 'Choose Template' field. The example below shows that message `Default.wma` has been selected as the template.

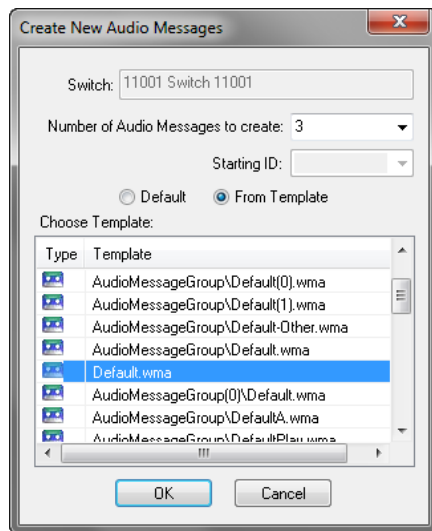

6. Click **OK** to create the new audio messages. Click *Cancel* to stop the creation process.

The new messages appear in the tree view

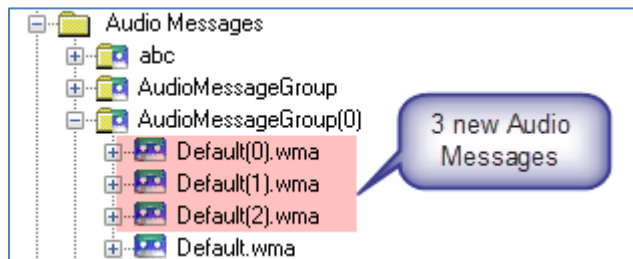

You will also see the following confirmation message:

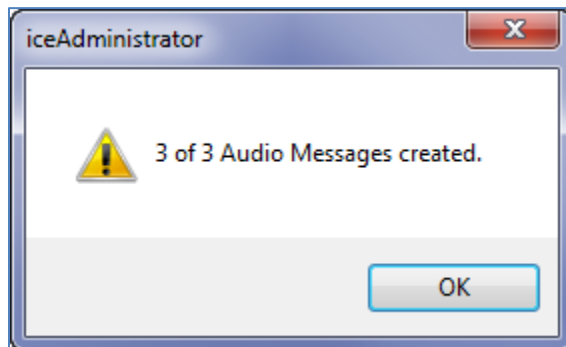

7. From the File menu, choose 'Save.' (To cancel the save operation, click *Cancel* on the 'Progress' dialog box.)

This section has explained how to add multiple audio messages to iceAdministrator. You may need to configure the new audio messages so that they can be used in the workflow. For more information on audio message properties, refer to the 'Audio Message Properties' tables in General Audio Message Properties on page 71 and Specific Audio Message Properties on page 71.

Adding an Audio Message from the Properties of an Action

You can create a new audio message from a dropdown list on the properties page of a workflow action that requires the selection of an audio message.

To create an audio message from the Properties box of a workflow action:

1. Navigate to the appropriate workflow.
2. Double-click the action from which you would like to create the audio message.
3. In the field that requires an audio message, for example, the 'Message Name' field in the Properties page of the Play Audio File action, select '<NEW AUDIO MESSAGE>' from the dropdown list.

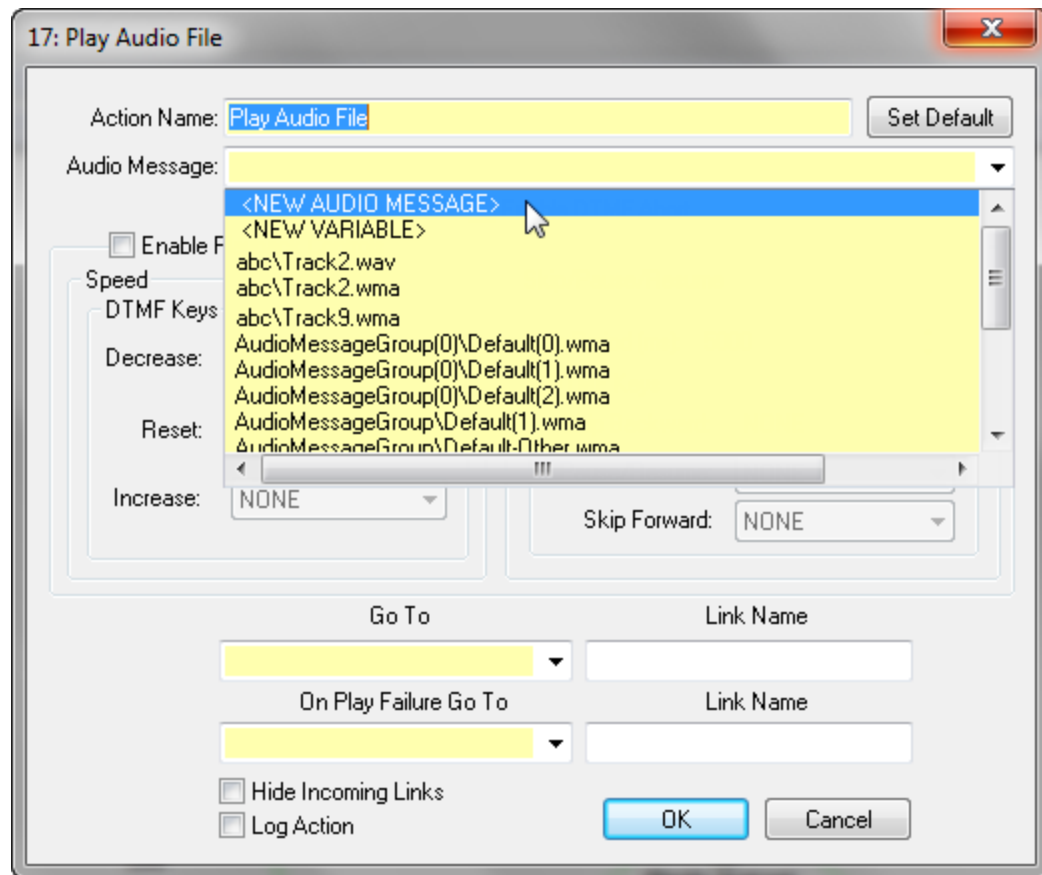

4.

5. You can also right-click the arrow in the dropdown list and select 'Audio Message' from the menu that appears.

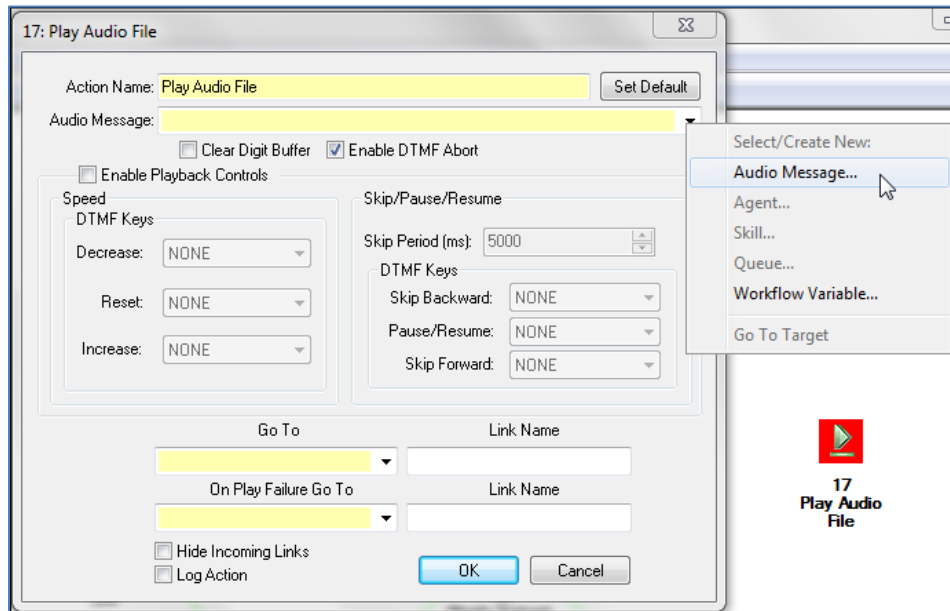

The 'Select Audio Message' dialog box appears.

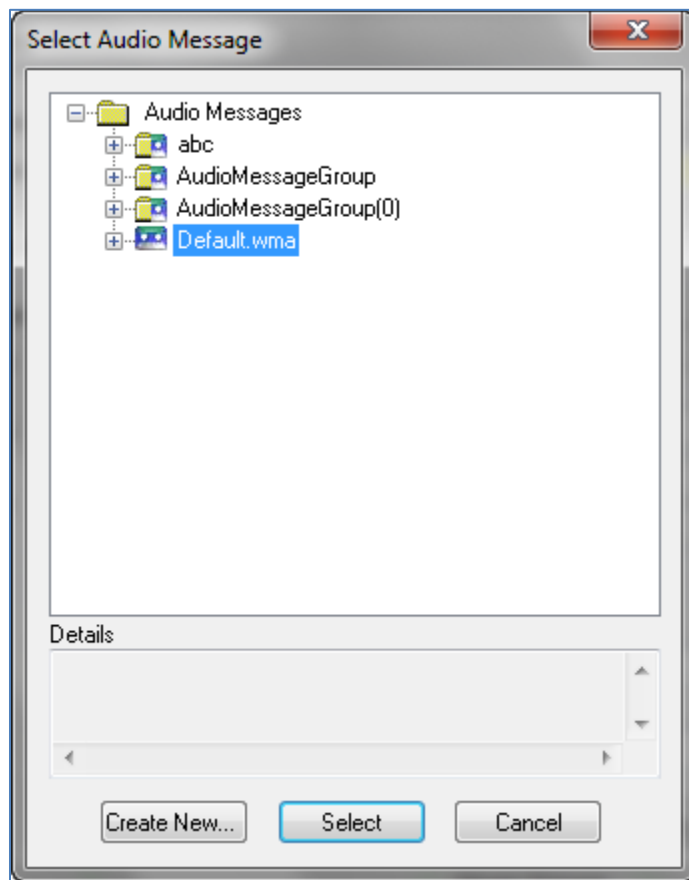

6. Click the *Create New* button on this dialog box.

The 'New Audio Message' dialog box appears. This dialog box allows you to create a new audio message and add it to a base subdirectory if that is needed.

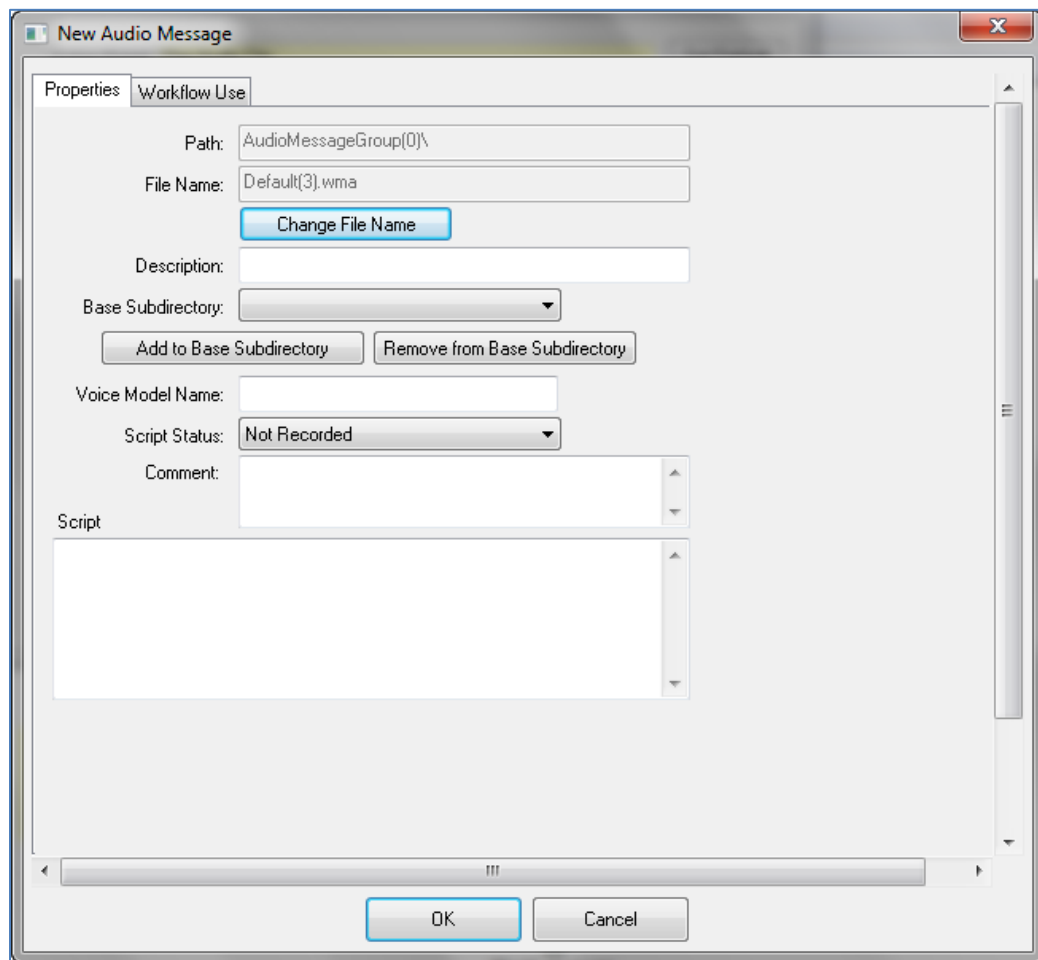

7. Click *OK* on this dialog box to add the audio message.

The audio message is added to the tree view and becomes the selected option in the workflow action field.

8. From the File menu, choose 'Save.' (To cancel the save operation, click *Cancel* on the 'Progress' dialog box.)

Adding an Audio Message to a Base Subdirectory

To add an audio message to a base subdirectory:

1. Right-click on the audio message in the tree view.

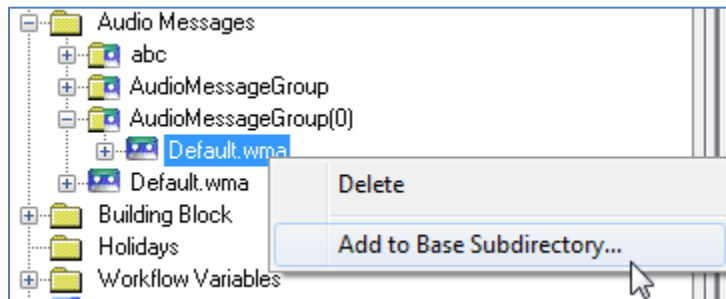

2. Select 'Add to Base Subdirectory' from the menu.
3. In the 'Add Audio Message to Base Subdirectory' dialog box, select a base subdirectory from the dropdown list, or create a new one by entering the name in the text box.

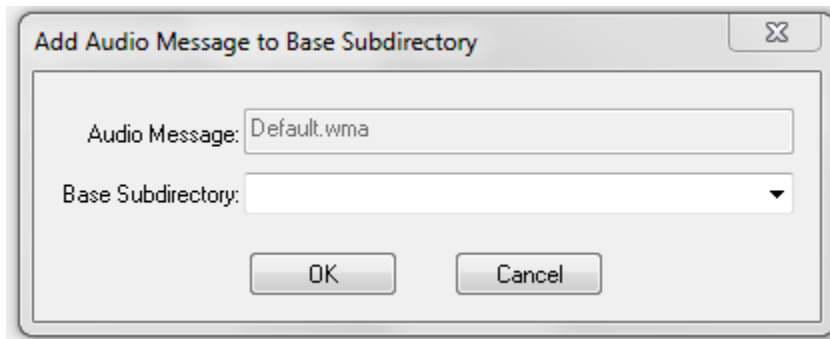

4. Click *OK*. (Click *Cancel* to cancel the operation.)
5. From the File menu, choose 'Save.' (To cancel the save operation, click *Cancel* on the 'Progress' dialog box.)

To remove an audio message from a base subdirectory:

1. Click on the audio message in the tree view.
2. Right-click on the base subdirectory you want to remove.
3. Select 'Delete' from the menu.

Once you have created a new audio message, you can configure unique properties for the message. For information on audio message properties, refer to page 71.

Moving an Audio Message

You may need to move an audio message from the main Audio Message folder (i.e., a message that does not belong to a particular group) to an audio message group, from one audio message group to another, or from an audio message group to the Audio Message folder.

Note: Audio messages cannot be moved from a Building Block to the main Workflow folder or from the main Workflow folder to a Building Block.

To move an audio message:

1. Right-click on the Audio Messages folder or a particular Audio Messages Group folder in the tree view.

A menu appears.

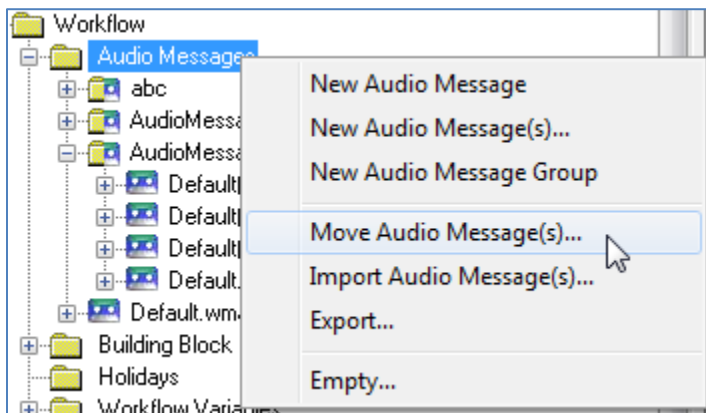

2. Select 'Move Audio Message(s)' from the menu.

If you have any windows open in the detail view of iceAdministrator, a message box appears.

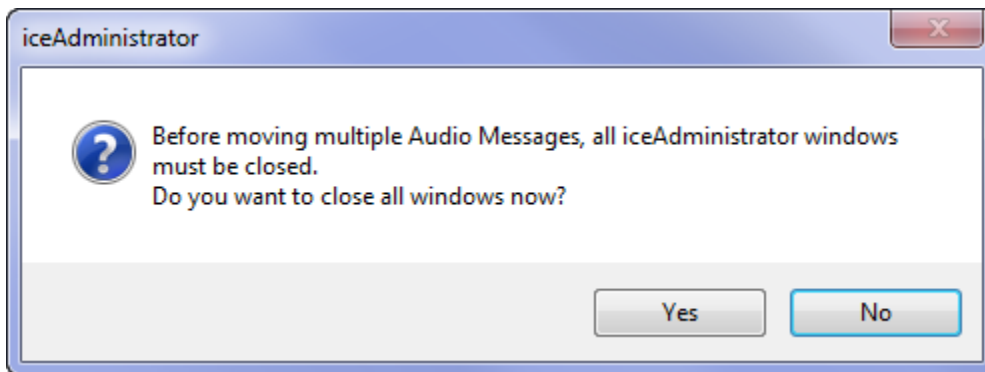

3. Click *Yes* to close all windows in the detail view (or click *No* if you do not want to continue).

Upon clicking *Yes*, the 'Move Audio Messages' dialog box appears:

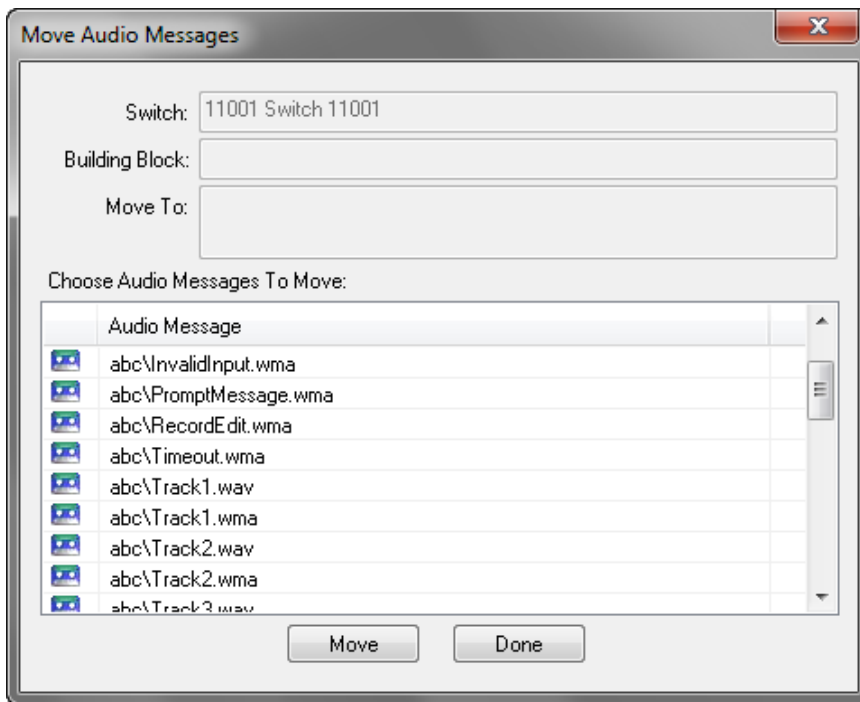

The 'Move Audio Messages' dialog box displays a list of messages that exist in other folders. For example, if you right-clicked on an audio message group in step 1, the list contains messages that belong to other audio message groups, and messages that are part of the main Audio Message folder (i.e., messages that do not belong to an audio message group).

4. Select the audio message(s) you wish to move.

You can select more than one audio message by holding the 'Ctrl' and/or 'Shift' keys on your keyboard while clicking on the messages.

5. Click *Move*.

The selected messages are moved to the folder you selected in step 1, and a confirmation window appears.

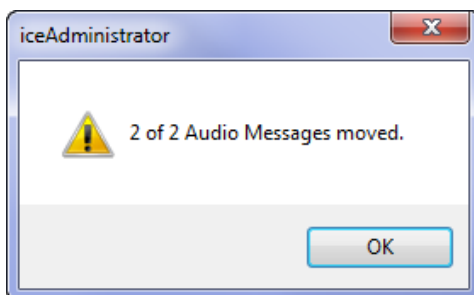

6. Click *OK* to close the confirmation window, and click *Done* to close the 'Move Audio Messages' dialog box.

7. From the File menu, choose 'Save.' (To cancel the save operation, click *Cancel* on the 'Progress' dialog box.)

Recording a Message

System Administration is usually accessed from the main menu for your contact center. This method of recording scripts, which is fully described below, is useful for those who wish to record messages using a phone that is not connected to the ice system.

Recording a Message with System Administration

Access to iceAdministrator is not required to record messages using System Administration. You can access System Administration by dialing the main contact center number and selecting a silent option. Once you access System Administration, you can select a message by entering the five-digit number associated with the message.

Note:

- For more information on accessing System Administration, refer to your training material or the Design Specification for your system.
- The instructions below assume that your contact center is using the standard System Administration application.

To record a message using System Administration:

1. Follow the instructions in your training material to access System Administration.
2. When prompted, press '1' to record scripts.
3. When prompted, press '1' to record English scripts or '2' to record French scripts.
4. When prompted, enter the five-digit message number followed by the # key.

If a message has already been recorded, it is played back over the phone. After the selected message is played back, you are prompted with several options, as described in the table below.

Message Options	
Option	Description
To record this message, press 1.	Press 1 to begin recording the message. Begin recording at the sound of the beep, and press # when you have completed the recording. A prompt message provides you with several options, as described in the table below.
To enter another message number, press 2	Press 2 to enter another message number. Return to Step 4, described above.
To hear this message again, press 3.	Press 3 to hear the message again. After the message is played back, options 1, 2, 3, and 9 are repeated, as described in this table.
To return to the System Administration main menu, press 9.	Press 9 to return to the System Administration main menu.

The table below describes the available post-recording options.

Post-Recording Options	
Option	Description
To save, press 1.	Press 1 to save the recording. When prompted, press 1 to record another message (it will take you to Step 4, as described above), or press 9 to return to the main menu (it will take you to Step 1, as described above).
To cancel, press 2	Press 2 to cancel the recording. When prompted, press 1 to record another message (it will take you to Step 4, described above), or to press 9 to return to the main menu (it will take you to Step 1, as described above).
To review the message, press 3.	Press 3 to hear the message you just recorded. Options 1 through 5 are repeated, as described in this table.

Post-Recording Options	
Option	Description
To start over, press 4	Press 4 to discard the message you just recorded and begin the recording again. Begin speaking after the beep, and press # when you have completed the recording. After you press #, options 1 through 5 are repeated.
To add to the message, press 5.	Press 5 to append a message to the message you just recorded. Begin recording after the beep, and press # when you have completed the recording. After you press #, options 1 through 5 are repeated, as described in this table.

Note:

- If you hang up your phone after a recording without making a selection (e.g., pressing 1 to save the message), the recording is not saved.
- To find the message number, view the message number in the 'File Name' field for each message. This can be found in iceAdministrator. You may also print the audio messages configuration report from iceReporting for a complete list of messages and message numbers.

Deleting an Audio Message

An audio message that is no longer required can be deleted.

To delete an audio message:

1. Navigate to the audio message that you wish to delete.
2. Right-click on the audio message in the tree view.

A menu appears.

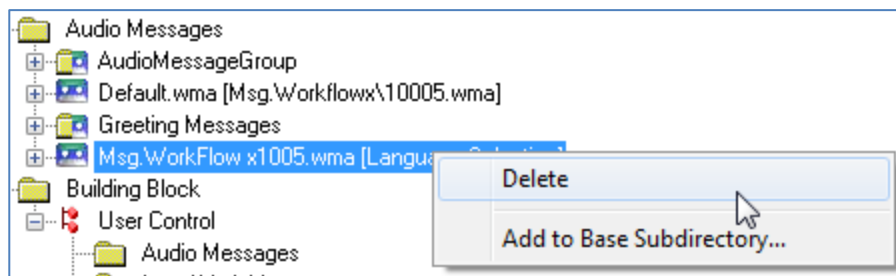

3. Select 'Delete' from the menu.

If this audio message is used in a workflow, a message box appears, indicating the audio message cannot be deleted:

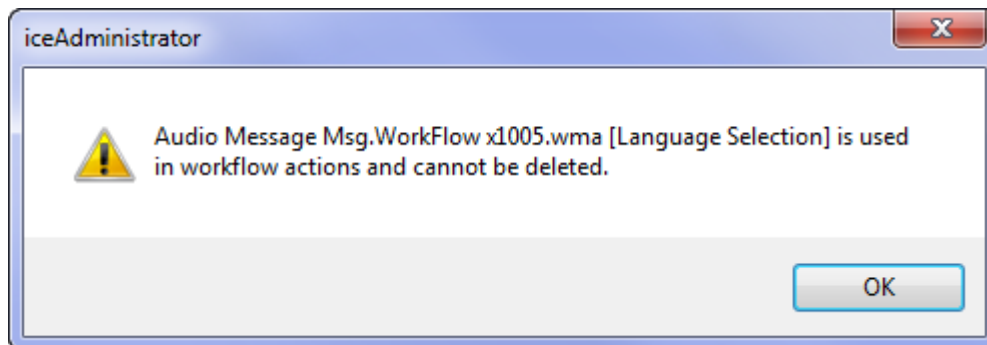

Modify the workflow, so the audio message is no longer used, then repeat Step 2.

4. From the File menu, choose 'Save.' (To cancel the save operation, click *Cancel* on the 'Progress' dialog box.)

Note: When you delete an audio message from iceAdministrator, the file that contains the recording for the message is not deleted from the ice server. If you create an audio message with a file name that has been previously used, the old message can be played.

This section has explained how to delete a single audio message. The following section provides information on deleting an audio message group.

Deleting an Audio Message Group

When you delete an audio message group all associated sub-groups and audio messages are deleted as well.

To delete an audio message group:

1. Navigate to the audio message group that you wish to delete.
2. Right-click on the audio message group in the tree view. A menu appears.
3. Select 'Delete' from the menu.

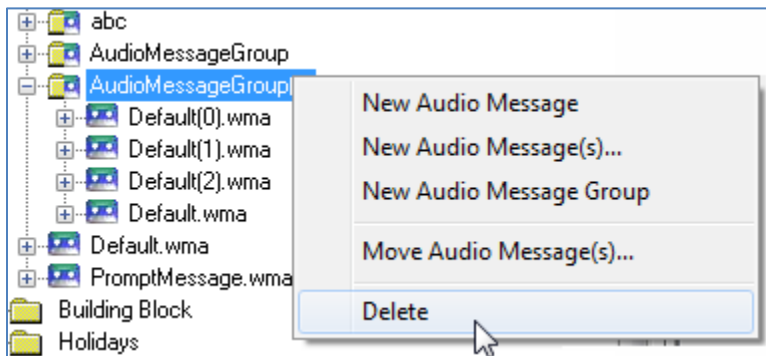

Note: If the audio message group contains audio messages that are used in a workflow, a message box appears.

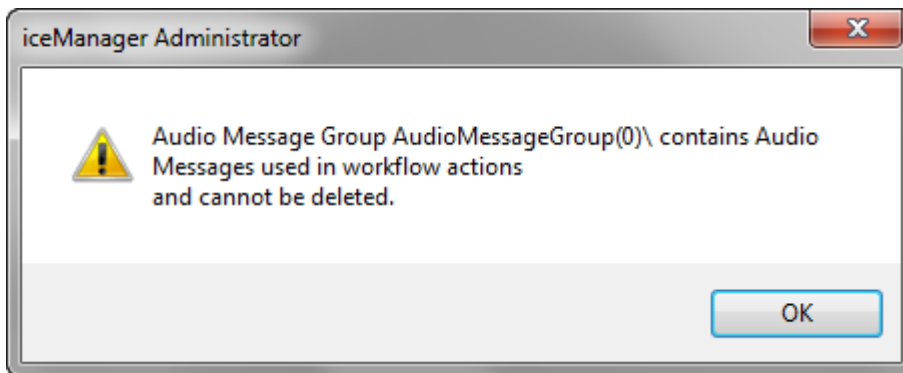

Click OK on the message box. Modify the necessary workflow so that any related audio messages are no longer used and then try the deletion again.

4. A confirmation box appears. Click *Yes* to delete the audio message group. Click *No* to cancel the deletion.

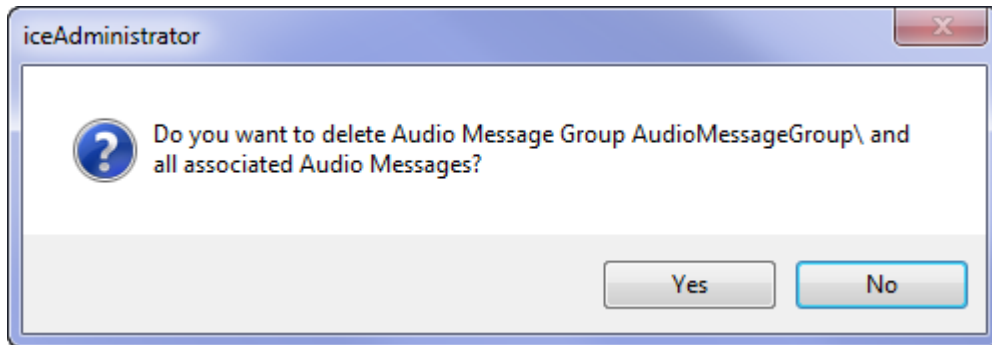

5. From the File menu, choose 'Save.' (To cancel the save operation, click *Cancel* on the 'Progress' dialog box.)

This section has explained how to delete an audio message group. The following section provides information on deleting all audio messages.

Emptying the Audio Messages Folder

You may decide to delete all audio messages to avoid conflict messages when you are importing audio messages.

To delete all audio messages:

1. Right-click on the Audio Messages folder.

A menu appears.

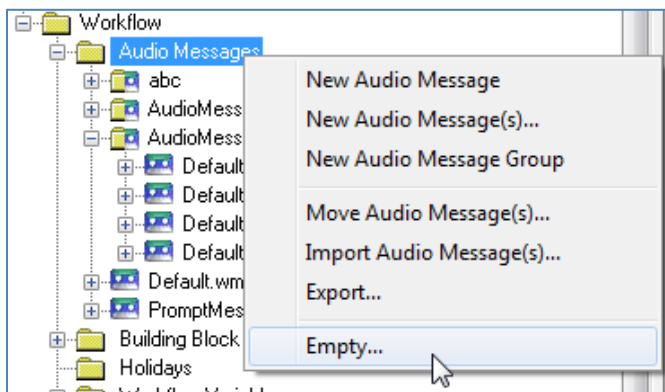

2. Select 'Empty' from the menu.

A warning appears.

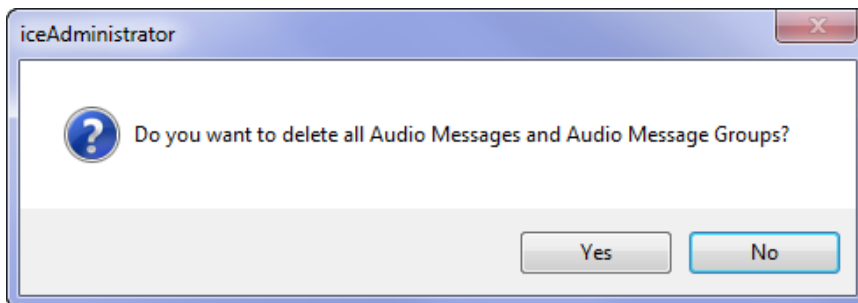

3. Click *Yes* to delete all of the audio messages. Click *No* to cancel the deletion.
4. From the File menu, choose 'Save.' (To cancel the save operation, click *Cancel* on the 'Progress' dialog box.)

Note:

- If the audio message that you delete is used in a workflow, the actions where the message is used will be incomplete – they will show a red background. You must complete the actions before you can save your changes.

- When you delete an audio message from iceAdministrator, the file that contains the recording for the message is not deleted from the ice server. If you create an audio message with a file name that has been previously used, the old message is played unless a new one has been recorded.



Chapter 3: Holidays

Using the Check Time Schedule action, the workflow can be designed to provide special treatment to contacts that arrive on a holiday.

To use holidays:

- A holiday must be added to iceAdministrator, as described on page 75.
- The Check Time Schedule action in iceAdministrator must look for holidays as one of its conditions. For more information on configuring this action, refer to page 177.

The sections that follow describe how to create, use, and delete holidays.

Viewing Holidays

Workflow can provide special treatment to contacts that arrive on a holiday, provided that:

- The days that your contact center considers to be holidays are added to the Holidays folder, and;
- The Check Time Schedule action is used in the workflow to verify the current date against the dates that have been added to the Holidays folder.

To view holidays:

1. Double-click the Workflow folder.

The Holidays folder is displayed along with Audio Messages, Variables, and workflow graphs.

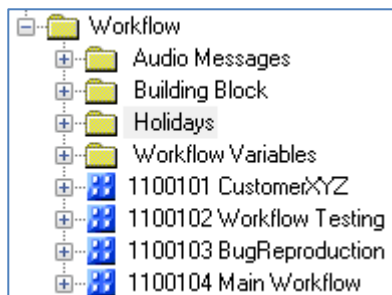

2. Double-click the Holidays folder in the tree view.

The holidays that have been created are displayed.

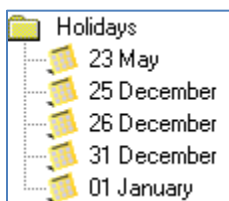

Highlighting a holiday simply shows the same date on the right side of the iceAdministrator window.

Note:

- ice stores the holiday month and date in the database. However, the year is not stored in the database. This is not a concern for holidays that fall on the same day each year (e.g., Canada Day, Independence Day, etc.). However, if the holiday does not have a fixed date (e.g., Easter), you will need to update the holiday each year. iceAdministrator will remind you to update the holiday in the new year.

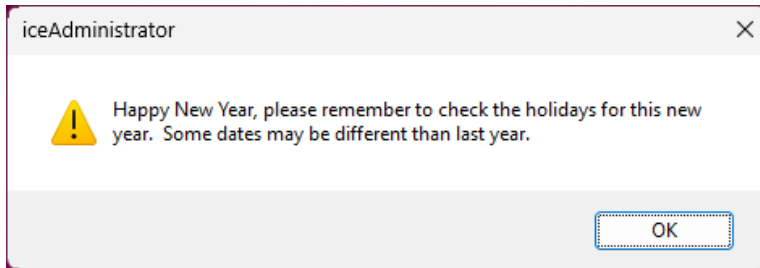

- The Check Time Schedule action allows you to select a specific date, which can include the year. For more information on this action, refer to page 177.

Adding a Holiday

Holidays are used in the Check Time Schedule action. If a contact passes through this action during a day that is defined as a holiday, the contact is routed to 'holiday' workflow (e.g., a workflow that plays a holiday message).

To add a holiday:

1. Right-click on the Holidays folder that is part of the Workflow folder.

A menu appears.

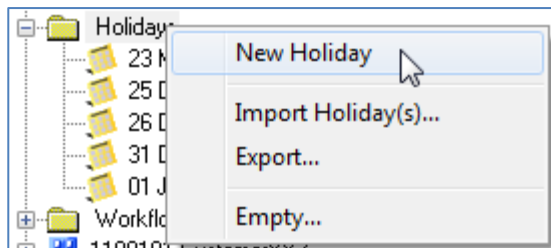

2. Select 'New Holiday' from the menu.

The right side of the iceAdministrator window displays the properties for the new holiday.

3. Use the dropdown calendar that is part of the 'Properties' page to select the holiday

The default value in the calendar is the current date.

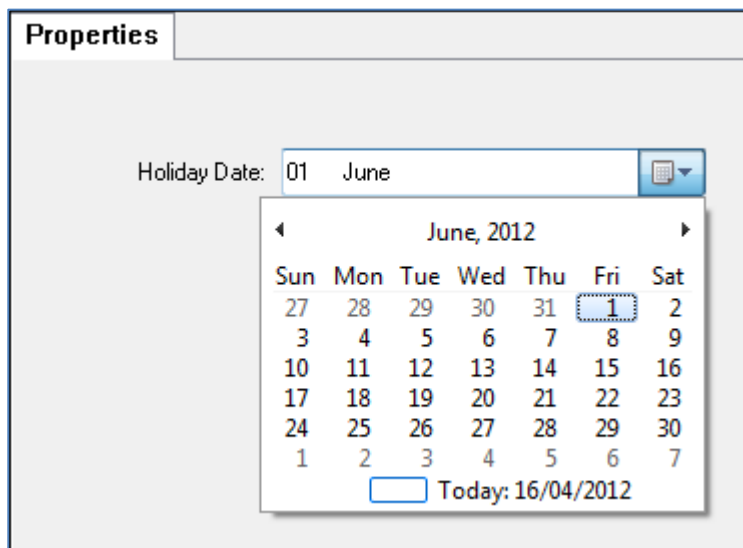

4. From the File menu, choose 'Save.' (To cancel the save operation, click *Cancel* on the 'Progress' dialog box.)

Deleting a Holiday

A holiday can be deleted if it is no longer needed.

To delete a holiday:

1. Navigate to the holiday that you wish to delete.
2. Right-click on the holiday in the tree view.

A menu appears.

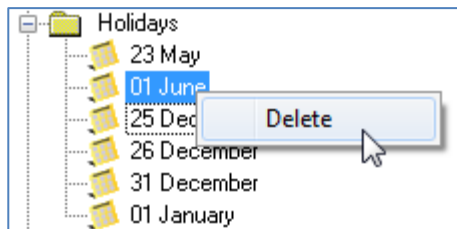

3. Select 'Delete' from the menu that appears.
4. From the File menu, choose 'Save.' (To cancel the save operation, click *Cancel* on the 'Progress' dialog box.)

This section has explained how to delete a single holiday. The following section provides information on deleting all holidays.

Emptying the Holidays Folder

You may decide to delete all holidays to avoid conflict messages when importing holidays.

To delete all holidays:

1. Right-click on the Holidays folder.

A menu appears.

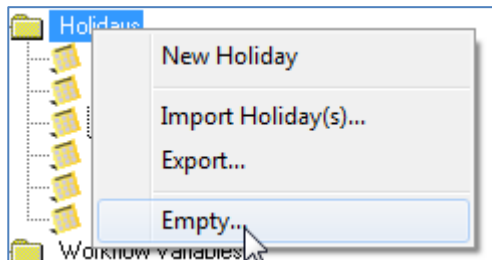

2. Select 'Empty' from the menu.

A warning appears.

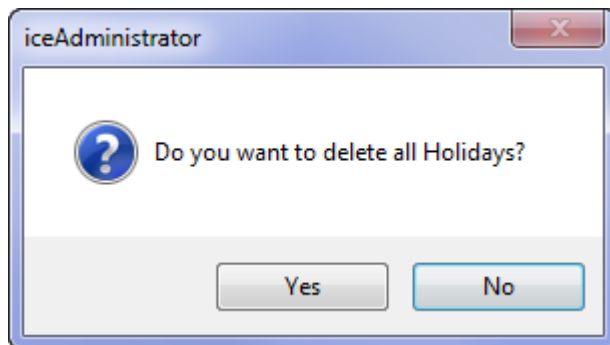

3. Click *Yes* to delete all of the holidays. Click *No* to cancel the deletion.
4. From the File menu, choose 'Save.' (To cancel the save operation, click *Cancel* on the 'Progress' dialog box.)



Chapter 4: Variables

Workflow allows for the creation of user-defined data variables, which hold data such as account numbers, audio message numbers, dates, etc.

You may create variables in the tree view in anticipation of requirements in the workflow. You can also easily create variables from workflow actions if you have not created them beforehand. When variables are no longer required, they can be deleted or purged.

The sections that follow provide information on:

- Variable scope
- How to create, delete, and purge user-defined variables
- Object variables, which are used to represent contacts.
- System variables, which cannot be created or deleted.



User-Defined Variables



Supervisor or Administrators can create two types of user-defined variables:

- **Data Variables** – hold information like account numbers, recorded messages, dates, etc.
- **Object Variables** – represent contacts as they move through the workflow. The value of an object variable is a unique number (also called the Contact ID) used within ice to identify the contact. Workflow requires at least one object variable. Typically @call is used to represent calls, @email is used to represent email messages, @autodial is used for the Create Auto Dial Request action, and @im is used to represent instant messages. Although Object Variables can be user-defined, the object variables that are required for your workflow are typically created for you during the implementation of your system.

Variable Scope

The scope of a user-defined variable depends on where it is created: For example, a variable created at the graph level is available to all pages within the graph, but a variable created at the page level is available to the page only. The table below provides details on variable scope:

Variable Scope			
Variable Icon	Creation Folder	Variable Naming Convention	Variable Scope
	Workflow Folder> Variables	@<VariableName>	Workflow: Accessible to any workflow graph or page that is part of the Workflow folder. These variables are not accessible to building blocks.
	Graph> Variables	@g_<VariableName>	Graph: Accessible to any workflow page that is part of the graph.
	Page> Variables	@p_<VariableName>	Page: Accessible to the workflow page.

Variable Scope			
Variable Icon	Creation Folder	Variable Naming Convention	Variable Scope
	Building Block> Variables	@b_<VariableName>	Building Block: Accessible to any workflow graph or page that belongs to the building block's routines.
	Routine> Variables	@r_<VariableName>	Routine: Accessible to any workflow graph or page that is part of the building block routine.

Note: System variables are accessible from any workflow page, including the workflow pages in building blocks. For more information on the system, variables refer to page 110.

Viewing User-Defined Variables

To view existing user-defined variables:

1. Double-click the Workflow folder.

The Variables folder is displayed along with Holidays, Building Blocks, Audio Messages, and workflow graphs.

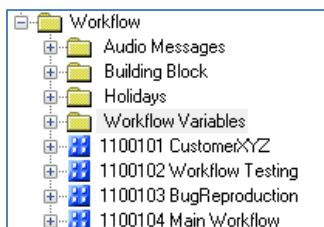

2. Double-click the Variables folder to view existing variables.

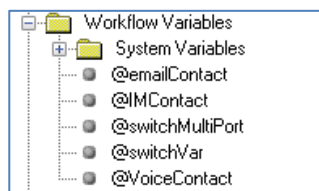

You can also navigate to the variables folder for a specific workflow graph, workflow page, building block, or building block routine.

3. Highlight the variable to see more information about that variable.

The properties of the selected variable are displayed in the detail view. For a complete description of the variable properties, refer to the following section.

The screenshot shows the 'Properties' window with the 'Workflow Use' tab selected. The variable name is '@emailContact'. The Variable ID is '%102'. The Port Scope is set to 'Single-Port'. The Variable Type is 'OBJECT'. There are three checkboxes: 'Read Only' (unchecked), 'Do not log variable value' (unchecked), and 'Set Default Value' (unchecked). The Default Value field is empty. The Summary field is also empty.

4. Click the 'Workflow Use' tab to see the actions that use this variable.

The screenshot shows the 'Properties' window with the 'Workflow Use' tab selected. The 'Used in Actions:' section is visible, along with a 'Go To Workflow Action' button. The table below lists the actions that use the variable.

Assigned	Graph	Page ID	Page	Action ID	Action
<input type="checkbox"/>	1100101 Customer XYZ	1	Start Page	1	Wait for Incoming Call
<input checked="" type="checkbox"/>	1100101 Customer XYZ	1	Start Page	2	Queue Object
<input type="checkbox"/>	1100101 Customer XYZ	2	Email	1	Wait for Instant Message
<input checked="" type="checkbox"/>	1100101 Customer XYZ	2	Email	7	Queue in 6004, Finance and Adm
<input checked="" type="checkbox"/>	1100101 Customer XYZ	2	Email	8	Queue in 6000, Customer Suppor
<input type="checkbox"/>	1100102 Greetings	1	Workflow Greeting	1	Queue Object
<input type="checkbox"/>	1100102 Greetings	1	Workflow Greeting	4	Wait for Incoming Call
<input checked="" type="checkbox"/>	1100102 Greetings	2	French Greeting	1	Queue Object
<input type="checkbox"/>	1100102 Greetings	2	French Greeting	4	Wait for Incoming Call

The Workflow Use tab provides the name and action ID of the action that uses the variable, along with the location of the action (the graph name and page ID). You may need to use the scroll bar or change the size of the columns to view all the information.

The 'Assigned' column serves an informational purpose. A checkmark in this column indicates that the variable is assigned a value. For example, the 'Assigned' column may be helpful if you decide to turn an existing variable into a read only variable. Prior to making the variable 'Read Only' modifications must be made to the workflow so that it is not writing to the variable. The Workflow Use tab provides a link to each section of the workflow that is writing to the variable versus referencing the variable.

You can go directly to the action that uses the variable from this page by highlighting the desired action in the list and clicking the *Go to Workflow Action* button. You can also double-click the action in the list. The appropriate workflow page appears. The target action is selected on the page.

For more information on 'Read Only' and other options for within a variables properties, refer to User-Defined Variable Properties on page 110.

User-Defined Variable Properties

When you click on a variable, you can view its properties in the detail view, as described in the table below.

Variable Properties	
Property	Description
Variable Name	<p>Enter the variable name, which is always preceded by an identifier that begins with '@.' The exact identifier depends on the variable scope, as described in 'Variable Scope' on page 106.</p> <p>The variable name can be up to 40 characters in length (including the identifier).</p>
Variable ID	<p>Displays a unique ID for the variable. This ID is system generated and cannot be modified.</p>
Port Scope	<p>This only applies to 'Data' variables. Select 'Single-Port' or 'Multi-Port.' The default option is 'Single-Port.'</p> <p>A 'Single-Port' variable is available only to the port that particular contact is on. Each port has an independent copy of a single-port variable. For example, consider a single-port variable that has its value changed to 1. Other calls arriving on different ports will not see this change.</p> <p>A 'Multi-Port' variable is visible across all ports. For example, consider a multi-port variable that has a value of Y. The value of the variable may change from Y to N during a call. The next call that arrives on any port sees the new value (i.e., N, and not Y).</p>
Variable Type	<p>Select 'Data' or 'Object.' The default is 'Data.'</p> <p>'Data' variable type represents data, such as a date or an account number. The 'Object' variable type represents contacts.</p>

Variable Properties	
Property	Description
Read Only	<p>This only applies to 'Data' variables. Select this checkbox to indicate the variable is read only.</p> <p>The value of a read only variable can only be modified in the 'Default Value' field in the Properties page for the variable. It cannot be modified through the workflow.</p> <p>When the 'Read Only' checkbox is selected, the 'Set Default Value' checkbox is automatically selected, and a value for the variable must be specified in the 'Default Value' field.</p>
Set Default Value	<p>This only applies to 'Data' variables. Select this checkbox to set a default value for the variable.</p> <p>As long as the 'Read Only' checkbox remains checked, the default value can be changed in the workflow (e.g., with the Assign Value to Variable action).</p> <p>To reset the value of a variable that has been changed in workflow, use the 'Assign Value to Variable' action. For more information on this action, refer to page 166.</p> <p>When the 'Set Default Value' checkbox is selected, the variable value must be specified in the 'Default Value' field.</p>
Do Not Log Variable Value	<p>This only applies to 'Data' variables. This feature allows for increased security on sensitive information, such as credit card numbers or passwords.</p> <p>Select this checkbox to prohibit the value of the variable from being printed to any readable interface. For example, with this option selected, the value of the variable is not displayed in iceDiagnostics or ice log files, and cannot be parsed within the workflow.</p>
Default Value	<p>This only applies to 'Data' variables. Enter the default value for the variable.</p> <p>The 'Set Default Value' checkbox must be selected before you can enter a default value.</p> <p>The value can be up to 5000 characters in length.</p>

Variable Properties	
Property	Description
Summary	<p>A summary, or explanation, of the variable for informational purposes.</p> <p>The summary can be up to 255 characters in length.</p>

System Variables

System variables are populated with general system information or with information that is specific to a voice call, an email message, or an instant message:

- General system variables (e.g., `$System:CurrentTime`) are initiated when the ice server is started or when an event takes place.
- System variables for voice calls (e.g., `$Call:CalledNumber`) are captured as callers pass through the Wait for Incoming Call or Assign DN actions.
- System variables for email messages (e.g., `$Email:SenderAddress`) are captured as email messages pass through the Wait for Incoming Email action.
- System variables for instant messages (e.g., `$IM:SenderAddress`) are captured as instant messages pass through the Wait for Instant Message action.

The table below describes all system variables for voice calls. (Additional tables follow to describe system variables for email messages, instant messages, and general system variables.)

System Variables for Voice Calls	
Variable	Description
<code>\$Call:CalledNumber</code>	Contains the number the caller dialed, i.e., the DNIS, if that information is available.
<code>\$Call:CallerName</code>	Contains the caller's name, i.e., the ANI name, if that information is available.
<code>\$Call:CallerNumber</code>	Contains the caller's number, i.e., the ANI number or the Caller Line ID if that information is available.

System Variables for Voice Calls	
Variable	Description
\$Call:CallReason	<p>Contains a number between 0 and 3.</p> <p>0 indicates the call reached workflow directly from the Wait for Incoming Call action.</p> <p>1 indicates the call reached workflow directly from Assign DN action (the call must proceed to the Wait for Incoming Call action after dialing the appropriate DN for this value to be set).</p> <p>2 indicates the call was transferred to the workflow by a user.</p> <p>3 indicates that workflow created the call (i.e., with the Wait for Call action).</p>
\$Call:PreviousParty	<p>Contains the user ID of the last user to handle the call. If a call arrives and has not yet been handled by a user, the value of this variable will be 0.</p>
\$Call:RedirectNumber	<p>If the call is redirected before it is routed to ice, this variable contains the number of the last party that redirected the call.</p>
\$Call:ReRoutingUser	<p>Contains the ID of the forwarding user when a direct call to a user has been redirected as a result of the user's call forwarding configuration.</p>

System Variables for Voice Calls	
Variable	Description
\$Call:ReRoutingReason	<p>Contains a number between 1 and 4 when a direct call to a user has been redirected as a result of the user's configuration for call forwarding.</p> <p>1 = CFAC – the call overflowed as a result of the Call Forward All Calls setting.</p> <p>2 = CFNA – the call overflowed as a result of the Call Forward No Answer setting.</p> <p>3 = CFPO – the call overflowed as a result of the Call Forward PAQ Overflow setting.</p> <p>4 = CFNL – the call overflowed as a result of the Call Forward No Logon setting.</p> <p>For more information on call forwarding, refer to the <i>iceAdministrator User Manual</i>.</p>
\$Call:ContactGroupName	Contains the name of the contact group that received the call.
\$Call:ContactGroupNumber	Contains the number of the contact group that received the call.

The table below describes all system variables for email messages:

System Variables for Email Messages	
Variable	Description
\$Email:EmailGroupName	Contains the name of the email group on which the email arrived.
\$Email:EmailGroupNumber	Contains the email group number on which the email arrived.
\$Email:IntendedUserID	If a specific user handled the message thread previously, the user's ID is contained in this variable. Otherwise, the value will be 0.
\$Email:ReceivingAddress	Contains the address to which the email has been sent.
\$Email:SenderAddress	Contains the sender's email address.
\$Email:SenderName	Contains the sender's name.
\$Email:Subject	Contains the text the sender has entered into the subject header.
\$Email:TrackingNumber	Contains a system generated tracking number.
\$Email:LastHandlingAgent	Represents the last handling agent for a message thread.
\$Email:OtherHandlingAgents	Represents all other handling agents for a message thread.
\$Email:InternalCCAddresses	Contains a comma-delimited list of addresses that were copied on the previous agent reply message on the thread.
\$Email:ExternalCCAddresses	Contains a comma-delimited list of addresses that were copied by the customer on the last inbound message to ice.

The table below describes all system variables for instant messages:

System Variables for Instant Messages	
Variable	Description
\$IM:IMGroupName	Contains the name of the IM group on which the instant message arrived.
\$IM:IMGroupNumber	Contains the IM group number on which the instant message arrived.
\$IM:ReceivingAddress	Contains the address to which the instant message has been sent.
\$IM:SenderAddress	Contains the sender's IM address.
\$IM:SenderName	Contains the sender's name.

The table below describes all general system variables:

General System Variables	
Variable	Description
\$System:ContactID	Contains a unique identifier for a contact.
\$System:ContactType	Contains the type of contact according to the following list: CONTACT_TYPE_NONE = 0 CONTACT_TYPE_VOICE_CALL = 1 CONTACT_TYPE_IM = 3 CONTACT_TYPE_CALLBACK = 4 CONTACT_TYPE_AUTODIAL_REQUEST = 5 CONTACT_TYPE_EMAIL = 6 CONTACT_TYPE_APPSHARING = 7 CONTACT_TYPE_NON_MCH = 8

General System Variables	
Variable	Description
\$System:CurrentDateTime	<p>Contains the current date in the following string format: YYYY,MM,DD,DW,hh,mm,ss,III</p> <p>Where: YYYY = year, from 1601 to 9999 MM = month, from 1 to 12 DD = day of the month, from 1 to 31 DW = day of the week, from 0 (Sunday) to 6 (Monday) hh = hours, from 0 to 23 mm = minutes, from 0 to 59 ss = seconds, from 0 to 59 III = milliseconds, from 0 to 999</p>
\$System:CurrentTime	<p>Contains the number of seconds that have elapsed since midnight (i.e., 00:00:00) of January first, 1970, co-ordinated universal time, according to the system clock. This value is useful for calculating time differences.</p>
\$System:DialedNumber	<p>If you have implemented an outbound workflow, this variable contains the number a user has dialed.</p> <p>Note: This variable is only available for voice.</p>
\$System:PrintableCurrentDate	<p>Contains the current date in the following format: DD/MM/YYYY.</p>
\$System:PrintableCurrentTime	<p>Contains the current time, based on a twenty-four hour clock, in the following format: HH:MM:SS.</p>
\$System:ResultCode	<p>Contains low-level result codes for action failures and successes. For a complete list of Result Codes, refer to Appendix C: Result Codes</p>

General System Variables	
Variable	Description
\$System:SwitchID	Contains the Switch ID.

The table below describes the building block system variable:

Building Block System Variable	
Variable	Description
\$BuildingBlock:BaseDir	Contains the building block base directory: ' <code>\BBlock\<BuildingBlockName></code> .' This variable is empty outside of the building block.

Adding Variables in the Tree View

You may create variables in the tree view in anticipation of requirements in workflow or to initialize read only variables.

To create variables in the tree view:

1. Right-click on the Variables folder to which you wish to add a variable.

A menu appears.

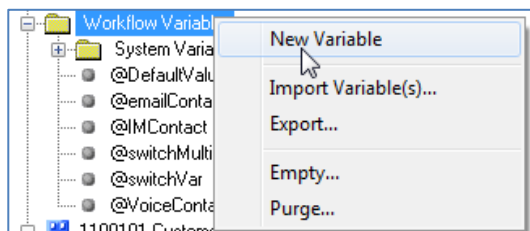

For a complete list of locations where a variable can be created, refer to Variable Scope on page 106.

2. Select 'New Variable' from the menu.

The right side of the iceAdministrator window displays the properties for the new variable.

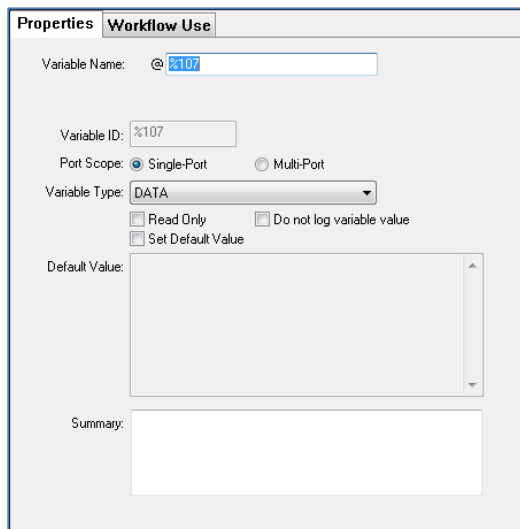

3. Complete the properties of the variable, as described in User-Defined Variable Properties on page 110.

The new variable appears in the tree view.

4. From the File menu, choose 'Save.' (To cancel the save operation, click *Cancel* on the 'Progress' dialog box.)

The variable is not used until an action is configured to refer to it. The next section explains how variables can be created from the properties dialog box of a workflow action.

Adding Variables from the Properties of an Action

Variables can be created from the properties dialog box of certain actions. A variable that you create from a properties dialog box is added to the Variables folder in the tree view when you click *OK*.

There are two methods of creating variables from the 'Properties' page of an action.

- The first method applies to fields that can only contain a variable (for example, the 'Assign to Object' field in the Assign DN properties dialog box). You can type the new variable name directly into the field.
- The second method applies to all fields where you may want to use a variable to represent the data. Some fields allow static values to be entered (for example, the 'Digits to Dial' field in the Dial Digits properties dialog box), so you cannot create a variable by typing directly in the field. If it is available, you can use the '<NEW VARIABLE>' option in the dropdown list.

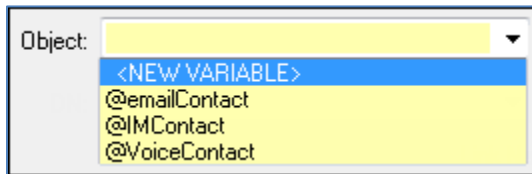

Creating Variables in Variable Fields

The field in which the variable has been created determines its variable type. For example:

- If you create a variable by typing the name of the variable in the 'Assign to Object' field of the properties dialog box for actions such as Wait for Incoming Call, Wait for Email, or Assign DN, the variable is added to the tree view as an 'Object' variable.
- If you create a variable by typing the name of the variable in the 'Variable' field of the Get Queue Status action properties dialog box, the variable is added to the tree view as a 'Data' variable.

Variables you create using these procedures always have the 'Page' level of variable scope and are added to the Variables folder for the page in the tree view when you click *OK* to close the dialog box. For more information on the variable scope, refer to page 106.

Use the table below to determine which action fields can be used to create 'Data' or 'Object' variables.

Variable Fields		
Action	Field	Allows You to Create...
User Control	Assign to Variable	Data Variables
Assign DN	Assign to Object	Object Variables
Assign Value to Variable	Variable	Data Variables
Create Auto Dial Request	Assign to Object	Object Variables
DB Connect	Assign DB Handle to Variable	Data Variables
DB Execute Query	Assign Query Handle to Variable	Data Variables
DB Execute Query	Assign Row Count to Variable	Data Variables
DB Next Record	Variable	Data Variables
Evaluate Expression	Result	Data Variables
Execute Building Block Routine	Result	Data Variables
Execute External Action	Assign Return Value to Variable	Data Variables
Get Caller Input	Store Caller Input In	Data Variables
Get Caller Input	Store Terminating Digit In	Data Variables
Get Object User Data	Store User Data in Variable	Data Variables
Get Queue Status	Variable	Data Variables
Get Speech Recognition Results	Store Recognition Results in Variable	Data Variables
Get Telephony Parameter	Store Parameter Value in Variable	Data Variables

Variable Fields		
Action	Field	Allows You to Create...
Receive Instant Message	Store Message in Variable	Data Variables
Record Audio File	Generate unique File Name and assign it to variable	Data Variables
Wait for Email	Assign to Object	Object Variables
Wait for Instant Message	Assign to Object	Object Variables

To create variables from one of the actions described in the table above:

1. From the workflow page, double-click the action from which you would like to create a variable.

The example below shows the properties dialog box for Assign DN.

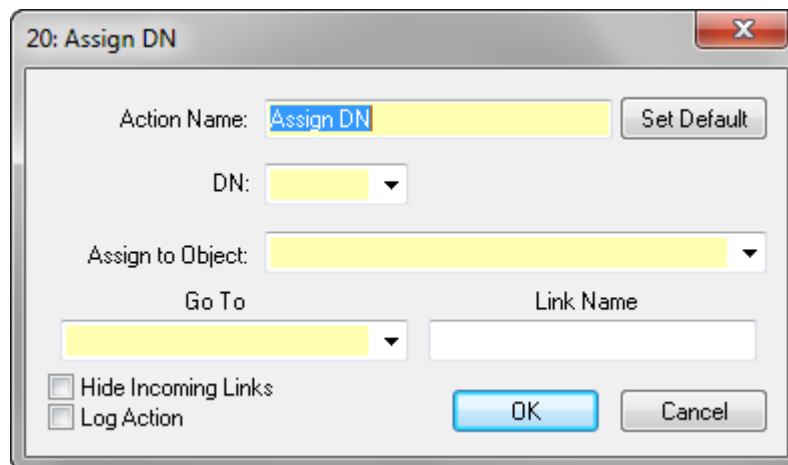

2. Type the name of the new variable in the 'Assign to Object' field.

A variable you create using this procedure always has the 'Page' level of variable scope, and is preceded by the identifier '@p_'. You can simply type the desired variable name, and the identifier will be pre-pended.

3. Click *OK* to close the dialog box and save your changes.

Notice that the new variable appears under the Variables folder for the page in the tree view. The variable type is automatically determined by the action field you used to create the variable. In this case, the variable has an 'object' type.

4. From the File menu, choose 'Save.' (To cancel the save operation, click *Cancel* on the 'Progress' dialog box.)

Creating Variables in Other Fields

To create variables for any fields where the '<NEW VARIABLE>' option is available from the dropdown list:

1. Double-click the action from which you would like to create a variable from the appropriate workflow page.

The example below shows the properties dialog box for Dial Digits.

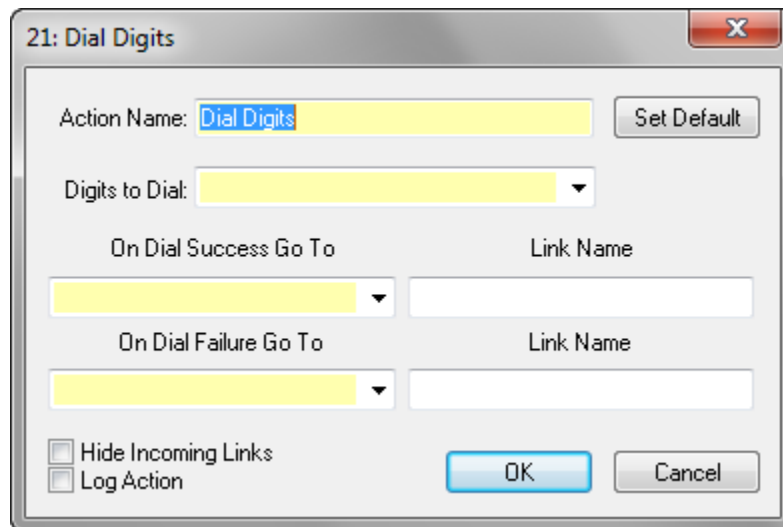

2. Select '<NEW VARIABLE>' from the 'Digits to Dial' dropdown list.

You can also right-click on the arrow in the 'Digits to Dial' dropdown list, and select 'Workflow Variable' from the menu that appears.

The 'Select Workflow Variable' dialog box appears.

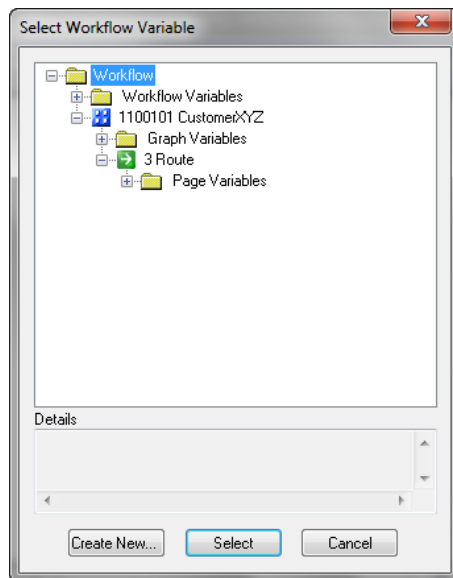

3. Select the Variables folder where you wish to create a new variable.

The folder that you select determines the variable scope. For more information on the variable scope, refer to page 106.

4. Click the *Create New* button.

The 'New Workflow Variable' dialog box appears. This dialog box has the same configuration tabs as the ones that appear when you create a variable from the tree view. For more information, refer to User-Defined Variable Properties on page 110.

5. Click *OK* to close the 'New Workflow Variable' dialog box and add the variable to the tree view.

Notice that the new variable appears under the selected Variables folder in the tree view.

6. From the File menu, choose 'Save.' (To cancel the save operation, click *Cancel* on the 'Progress' dialog box.)

Deleting a Variable

A variable can be deleted if it is no longer required.

To delete a variable:

1. Navigate to the variable that you wish to delete.
2. Right-click on the variable in the tree view.

A menu appears.

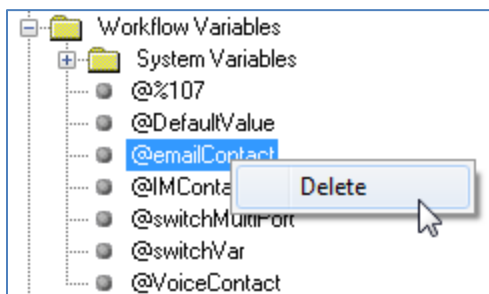

3. Select 'Delete' from the menu that appears.

If the variable is used in a workflow, a message box appears indicating it cannot be deleted.

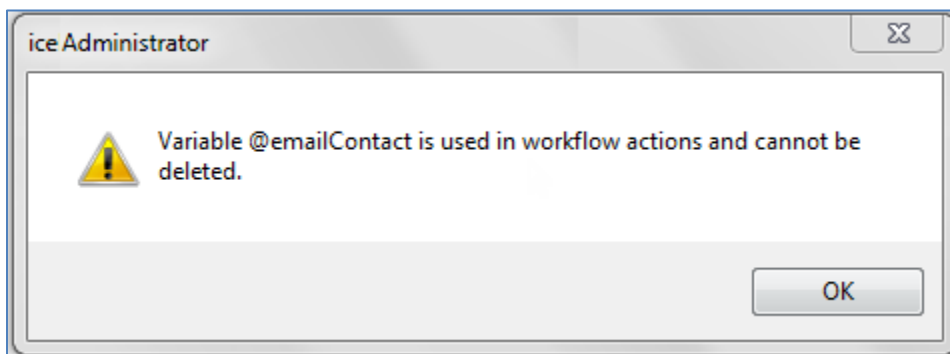

Modify the workflow, so the variable is no longer used, and then repeat Step 2. Use the 'Workflow Use' tab for a list of actions that refer to the variable. For more information, refer to

Viewing User-Defined Variables on page 107.

4. From the File menu, choose 'Save' (To cancel the save operation, click *Cancel* on the 'Progress' dialog box).

This section has explained how to delete a single variable. The following section provides information on deleting all variables.

Emptying a Variables Folder

You may decide to delete all variables to avoid conflict messages when you import files.

To delete all variables in a specific Variables folder:

1. Right-click on the Variables folder from which you wish to delete all variables.

A menu appears.

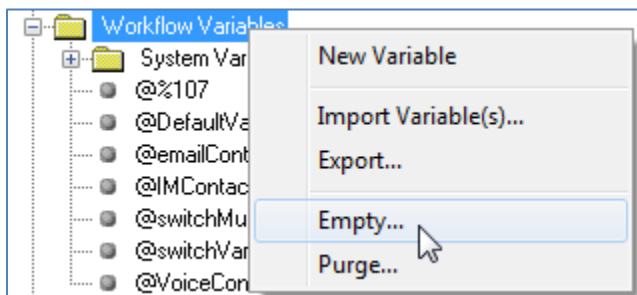

2. Select 'Empty' from the menu.

A warning appears.

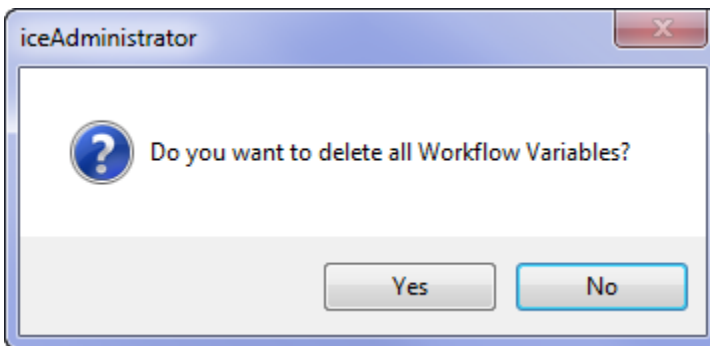

3. Click *Yes* to delete all of the variables. Click *No* to cancel the deletion.
4. From the File menu, choose 'Save.' (To cancel the save operation, click *Cancel* on the 'Progress' dialog box.)

Purging Unused Variables

Purging allows you to clean up Variables folders by deleting variables that are not referenced in the workflow.

To purge variables:

1. Right-click on the Variables folder from which you wish to delete all variables.

A menu appears.

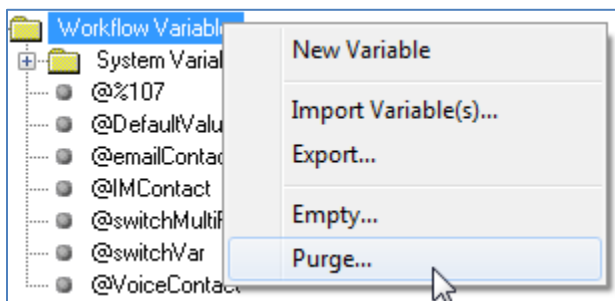

2. Select 'Purge' from the menu.

A warning appears.

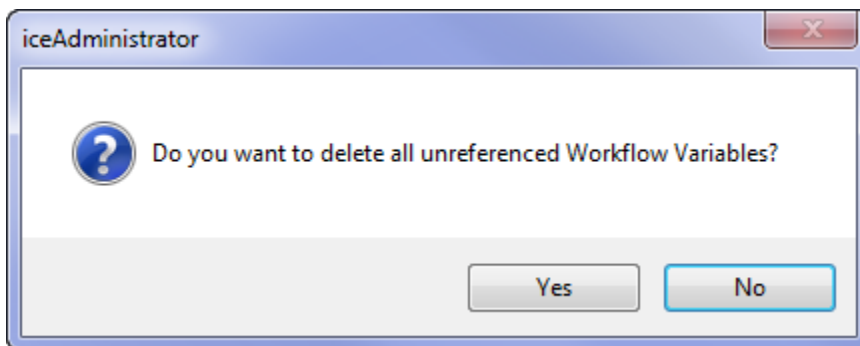

3. Click *Yes* to delete all variables that are not referenced in the workflow. Click *No* to cancel the deletion.
4. From the File menu, choose 'Save.' (To cancel the save operation, click *Cancel* on the 'Progress' dialog box.)



Chapter 5: Building Blocks

Building blocks are designed to contain re-usable workflow that is accessible from other points in the workflow. There may be instances where a contact is sent to a building block routine and then sent back to the workflow it came from. Workflow in a building block can be configured to return a value to the originating workflow, modify a value in the originating workflow, or perform some other operation that does not return or modify a value.

The following sections explain how to view, create, modify, and delete the components of a building block.

Note: This chapter assumes that you are familiar with the topics and features discussed in previous chapters - workflow, audio messages, holiday, and variables.

Viewing Building Blocks

Building blocks are housed in the Building Blocks folder. Each building block contains its own set of audio messages, variables, and one or more routines.

The following sections describe how to navigate to the various components of building blocks.

Navigating to a Building Block

To view a building block:

1. Double-click the Building Block folder in the tree view.

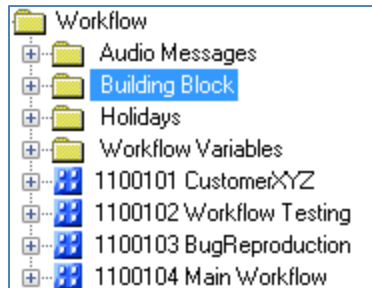

One or more building blocks are displayed.

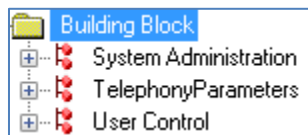

2. Click a building block to view its properties.

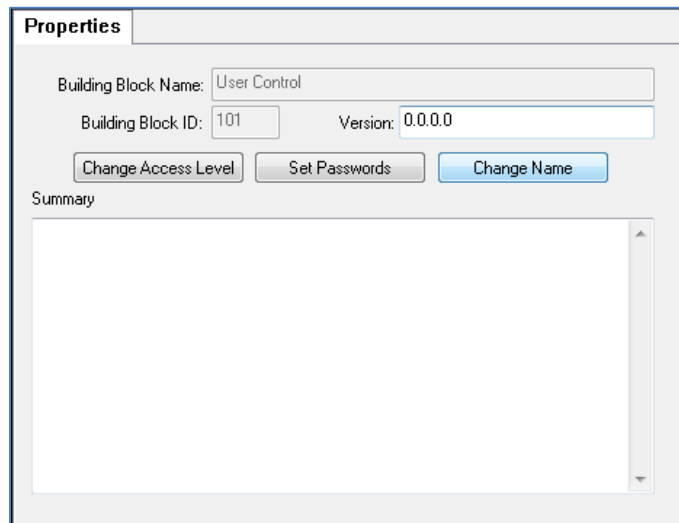

The properties of the selected building block are displayed on the right side of the iceAdministrator window. For a description of the building block properties, refer to Adding a Building Block on page 137.

3. Double-click the building block in the tree view to view its components.

Depending on the configuration of the building block and your level of access, you may see the Audio Messages folder, the Variable folder, and one or more routines. For more information on permissions for building blocks, refer to page 138.

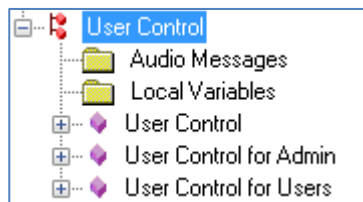

Building Block Audio Messages

Audio messages that have been created in the Audio Messages folder can be used in any routine that is part of the building block. By default, the audio messages are stored in the base directory 'BBlock\<<BuildingBlockName>.'. The exact name of the base directory is stored in a system variable called @BuildingBlock:BaseDir.

Audio messages created outside of the building block cannot be accessed by building block routines. Similarly, audio messages that belong to a building block are not accessible to workflow outside of the building block.

For more information on audio messages, refer to Chapter 2: Audio Messages.

Viewing a Routine

Routines are components of a building block. Each routine contains its own set of variables as well as workflow graphs and pages.

You must have an Administrator user type or higher to view all details for a routine. Depending on the configuration, you may also be required to enter a password in order to view details for the building block's routines. For more information, refer to Changing a Building Block Access Level on page 138.

To view a routine:

1. Click the routine in the tree view.

The properties of the selected routine are displayed on the right side of the iceAdministrator window. For a description of routine properties, refer to page 135.

The screenshot shows a software interface with two tabs: 'Properties' and 'Arguments'. The 'Arguments' tab is active. It contains the following fields and controls:

- Routine Name:** A text box containing 'User Control'.
- Routine ID:** A text box containing '3', with a 'Change Name' button to its right.
- Access:** Two radio buttons, 'Public' (selected) and 'Private'.
- Routine Entry Point:** A section containing three dropdown menus:
 - Graph:** '1 User Control'
 - Page:** '1 User Control Start'
 - Action:** '1 Compare Data'
- Go To Entry Point:** A button located below the dropdown menus.
- Summary:** A large, empty text area at the bottom of the window.

2. Click the 'Arguments' tab to see a list of the arguments for the routine.

An argument is a variable that represents the input required for a routine. For example, a routine may require the queue ID from which the contact originated. For more information on adding arguments to a routine, refer to

Adding Arguments on page 148.

Argument	Pass By	Default Value	Summary
@r_%20000000	Value	<NONE>	
@r_UserID	Reference	<NONE>	
@r_UserType	Reference	<NONE>	Used to determine which options are given to the caller acce:

The value for the argument is set in the originating workflow, using the Execute Building Block Routine action. For more information on configuring this action, refer to page 310.

3. Double-click the routine in the tree view.

Along with the routine's Variables folder, one or more workflow graphs are displayed, depending on the configuration of the routine, and your level of access. For more information refer to Changing a Building Block Access Level on page 138.

4. To view the workflow for the routine, expand the appropriate workflow graph and double-click the workflow page.

When viewing the entry point page for the routine, the action that has been defined as the starting point is displayed with a green background. For more information on viewing workflow, refer to Chapter 1: Introduction to Workflow.

Routine Properties

The routine properties are described in the table below.

Routine Properties	
Property	Description
Routine Name	When a routine is created, it is given a default name that includes the routine ID. For example, 'Default Name (16).'
	For information on changing the name of a routine, refer to page 145.
Routine ID	A unique identifier for the routine. The routine ID cannot be changed.
Change Name	Click this button to change the name of the routine. For more information, refer to page 145.
Access	If a routine is set to Public on the Routine Properties page, it can be accessed from another point in the workflow (i.e., from another routine in the same building block, another routine in a different building block, or from a page in the Workflow folder).
	If a routine is set to Private access, it can only be accessed by other routines within the building block.
Routine Entry Point	A graph, page, and action can be selected as the routine entry point. This determines the starting point for a contact that is directed to this routine. For more information, refer to page 144.
Go To Entry Point	Click <i>Go to Entry Point</i> to view the starting point for the routine.
Summary	A summary of the routine. This summary may include information such as a general description of the routine functionality.
	This field allows up to 799 characters.

Adding a Building Block

You may need to add a building block when you plan to import a routine or when you want to create new, re-usable workflow.

To add a building block:

1. Right-click on the Building Block folder that is part of the tree view.

A menu appears.

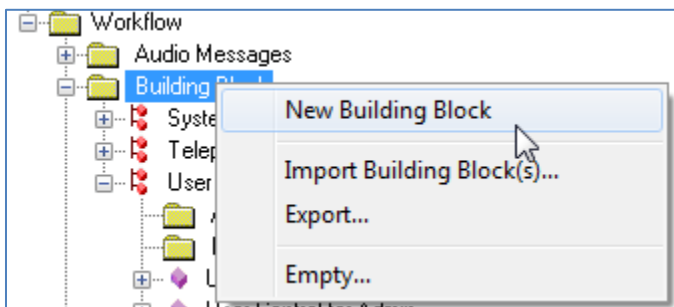

2. Select 'New Building Block' from the menu.

The right side of the iceAdministrator displays the properties for the new building block.

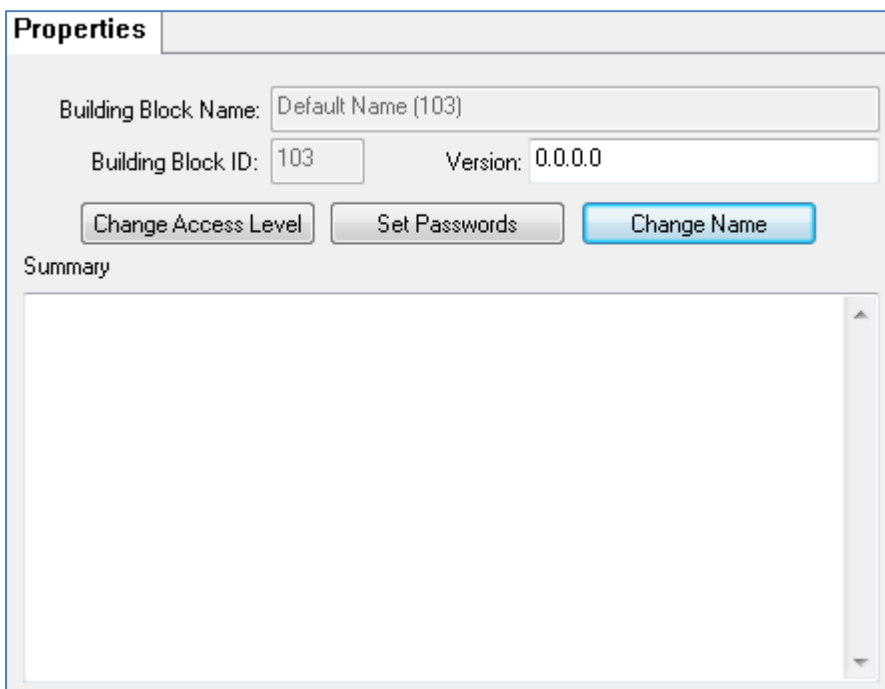

For details on setting passwords, changing the access level, or changing the name of the building block, refer to the sections that follow.

3. From the File menu, choose 'Save.' (To cancel the save operation, click *Cancel* on the 'Progress' dialog box.)

In this section, you have added a new building block. The following sections provide more information on modifying properties of a building block.

Changing a Building Block Access Level

By default, an iceAdministrator user with an Administrator user type (or higher) has full read and write access to building blocks.

If a building block is password protected, an Administrator user type (or higher) will be:

- Able to view the properties for routines that have the 'User' access type, but will not be able to view the variables, graphs, or pages for these routines. For more information routine properties, refer to page 135.
- Unable to view any information for routines that have the 'Private' access type. These routines are not visible in the tree view until a password is entered.
- Required to enter a password to gain read or write access to the building block.

For information on setting passwords for a building block, refer to page 138.

To change the access level:

1. Click *Change Access Level* on the properties page for the building block.

If you already have the highest level of access to the building block, the following message appears:

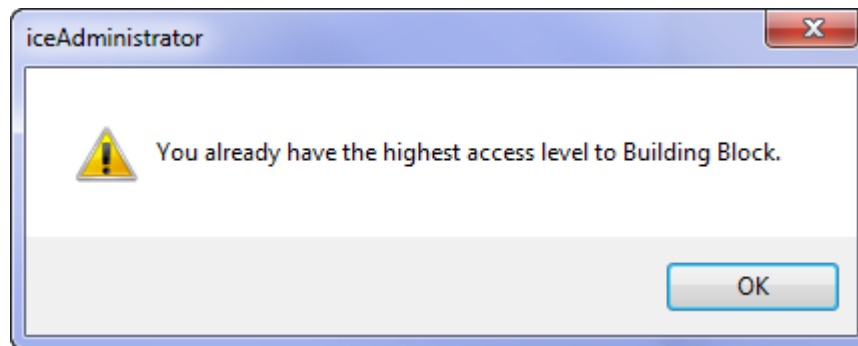

Otherwise, a warning message appears.

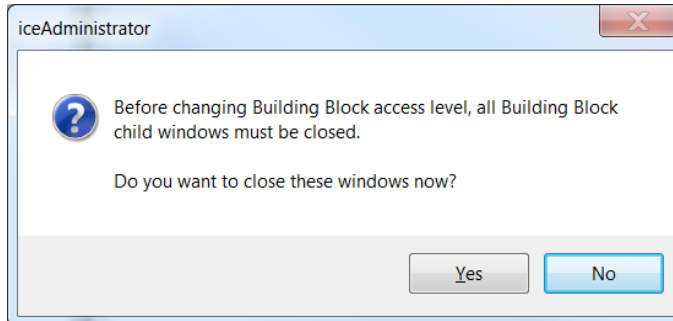

2. Click *No* if you do not want to continue or click *Yes* to close all windows in the detail view.

The 'Upgrade Building Block Access Level' dialog box appears.

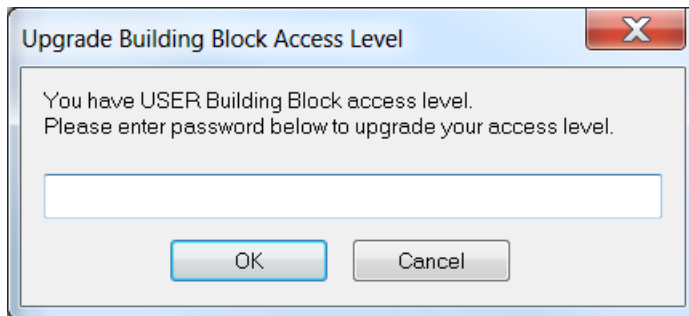

3. Enter either the read or write password, and click *OK*.

If you have entered the read password, a dialog box appears with the following text: 'You have READ access to the <building block name> Building Block now.' With reading access, you can view all components the building block, but cannot make modifications.

If you have entered the write password, a dialog box appears with the following text: 'You have WRITE access to the <building block name> Building Block now.' With write access, you can view and edit all components of the building block.

Setting Passwords

By default, an iceAdministrator user with an Administrator user type or higher can have full read and write access to building blocks. If passwords have been set for a building block, the user must enter a password to gain read or write access to the building block.

If using passwords, both passwords must be set. Once passwords have been set, the user cannot view or modify the workflow for any of the routines in the building block until the password has been entered.

Note: The *Set Passwords* button is not available unless you have writing access to the building block. For information on how to change your level of access for a building block, refer to *Changing a Building Block Access Level* on page 138.

To set passwords for a building block:

1. Click *Set Passwords* on the properties page for the building block.

The 'Set Building Block Password' dialog box appears.

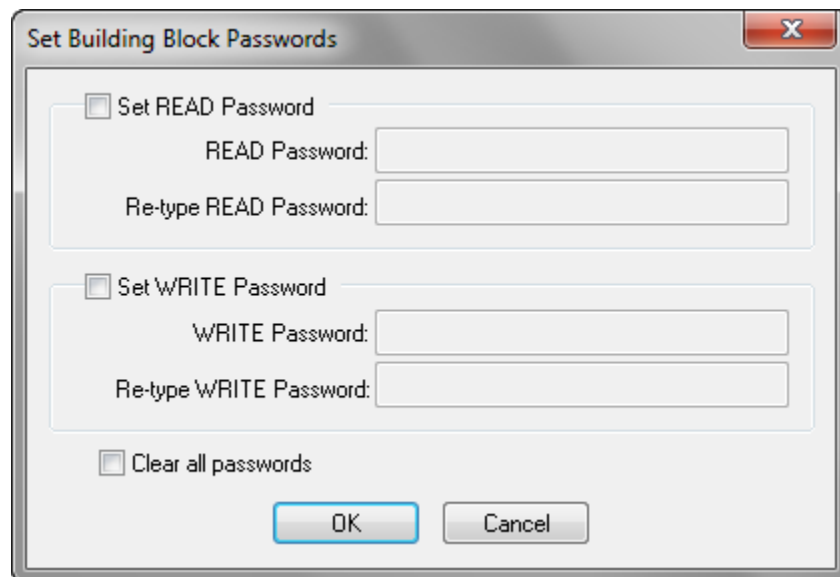

The dialog box is titled "Set Building Block Passwords" and features a close button (X) in the top right corner. It contains three main sections, each with a checkbox and two text input fields:

- Set READ Password: READ Password: [text box], Re-type READ Password: [text box]
- Set WRITE Password: WRITE Password: [text box], Re-type WRITE Password: [text box]
- Clear all passwords

At the bottom of the dialog are two buttons: "OK" and "Cancel".

2. Select the 'Set READ Password' checkbox, and enter the password in the 'READ Password' field. Re-enter the password in the 'Retype READ Password' field.
3. Select the 'Set WRITE Password' checkbox, and enter the password in the 'WRITE Password' field. Re-enter the password in the 'Retype WRITE' Password field.

4. Click OK to set the passwords and close the dialogue box.

If both the read and write passwords have not been set, the following warning appears.

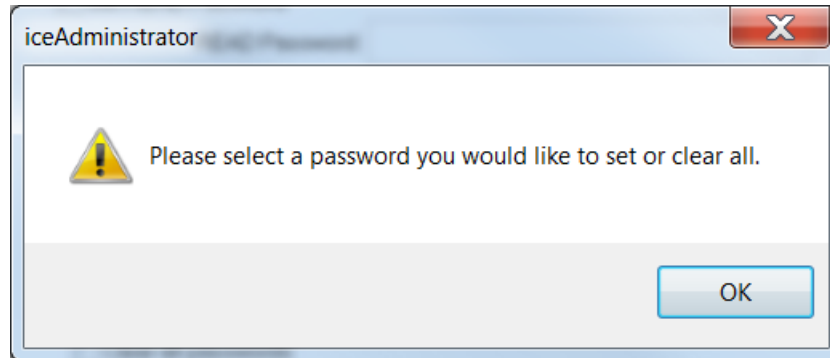

Click *OK* to return to the 'Set Building Block Password' dialog box and enter the appropriate information.

You can clear the passwords for the building block by selecting the 'Clear all passwords' checkbox.

If the read and write passwords have previously been set, you may reset the read and write passwords only by selecting that option.

5. From the File menu, choose 'Save.' (To cancel the save operation, click *Cancel* on the 'Progress' dialog box.).

Changing the Building Block Name

When a building block is created, it is given a default name that includes the building block ID. For example, 'Default Name (101)'. A building block name acts as a unique identifier, so each building block requires a unique name.

You may change a building block name, but if the building block has already been referenced by other points in workflow, you will be required to:

- Update the properties for the Execute Building Block Routine action. For more information on this action, refer to page 310.
- Update any reference to the building block using a variable.

Note: The *Change Name* button is not available unless you have writing access to the building block. For information on how to change your level of access for a building block, refer to Changing a Building Block Access Level on page 138.

To change the name for a building block:

1. Click *Change Name* on the properties page for the building block.

A warning message appears.

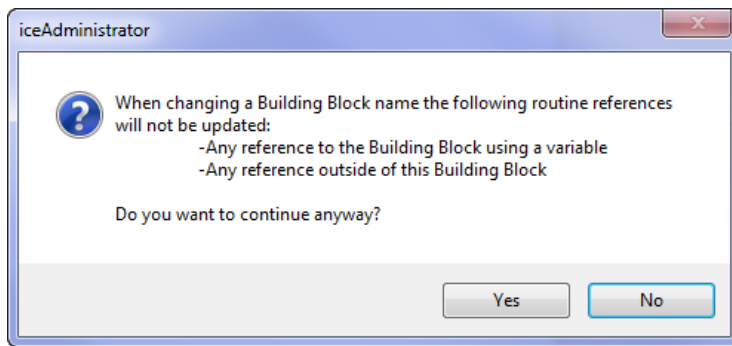

2. Click *Yes* to continue, or click *No* to close this window without making any changes to the building block name.

Upon clicking *Yes*, the 'Change Building Block Name' dialog box appears.

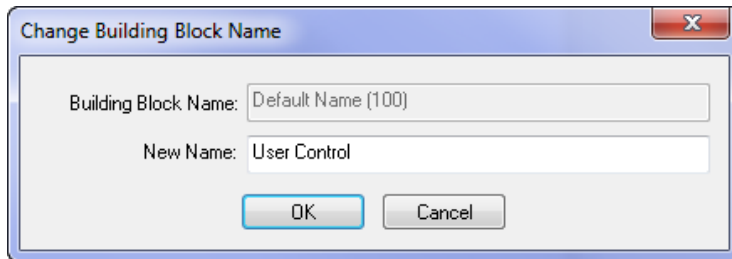

3. Enter the new name for the building block in the 'New Name' field.

The current name for the building block appears in the 'Building Block Name' field.

4. Click *OK* to change the building block name and close the dialog box.

Update other portions of workflow that reference the building block, as required.

5. From the File menu, choose 'Save.' (To cancel the save operation, click *Cancel* on the 'Progress' dialog box.)

Adding a Routine

You might need to add a routine if you are importing new workflow to a building block, or if you want to create a new workflow for a building block.

To add a routine:

1. Right-click on the building block that requires the new routine.

A menu appears.

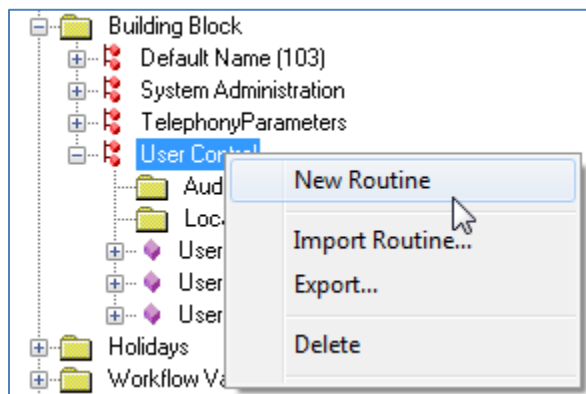

2. Select 'New Routine' from the menu.

The right side of the iceAdministrator displays the properties for the new routine.

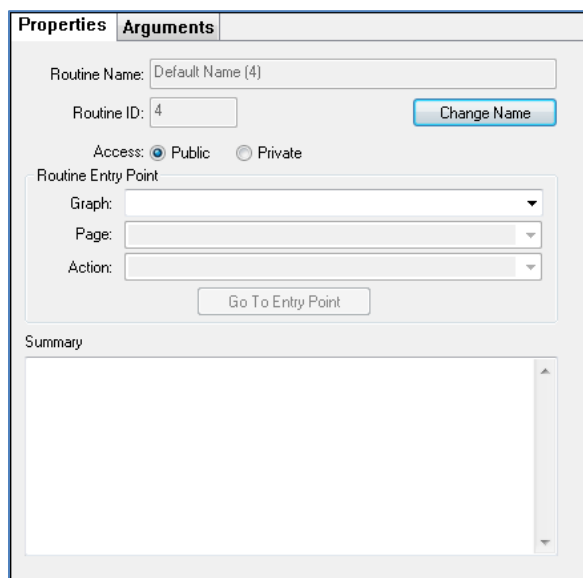
A screenshot of the 'Properties' tab in the iceAdministrator interface. The 'Routine Name' is 'Default Name (4)', 'Routine ID' is '4', and 'Access' is set to 'Public'. The 'Routine Entry Point' section includes dropdowns for 'Graph', 'Page', and 'Action', along with a 'Go To Entry Point' button. A 'Summary' section is visible at the bottom.

For more information on routine properties, refer to page 135. For information on defining the routine entry point, changing the routine name, setting routine access, and adding arguments, refer to the sections that follow.

You cannot save a new routine until you have defined a routine entry point, as described in the following section.

Defining the Routine Entry Point

A graph, page, and action can be selected as the routine entry point. This determines the starting point for a contact that is directed to this routine. You will not be able to save a routine until you have defined a routine entry point.

To specify the routine entry point:

1. Navigate to the routine for which you want to define an entry point.

For this process, you need to work with the 'Routine Entry Point' area that is part of the 'Properties' page.

The screenshot displays the 'Properties' tab of a software interface. At the top, there are two tabs: 'Properties' (selected) and 'Arguments'. Below the tabs, the 'Routine Name' is set to 'Default Name (4)' in a text box. To its right is a 'Change Name' button. Below that, the 'Routine ID' is '4' in a text box. Underneath, there are radio buttons for 'Access', with 'Public' selected and 'Private' unselected. The 'Routine Entry Point' section contains three dropdown menus: 'Graph' (set to '1 Default Name (1)'), 'Page' (set to '1 Default Name (1)'), and 'Action' (empty). A 'Go To Entry Point' button is located below these dropdowns. At the bottom of the form is a 'Summary' section with a large, empty text area.

2. Select the appropriate workflow graph from the 'Graph' dropdown list.

The graph that you select should contain the workflow page you wish to use as the starting point for the routine.

3. Select the appropriate workflow page from the 'Page' dropdown list.

Only the pages belonging to the graph you selected are listed.

4. Select the workflow action from the 'Action' dropdown list.

Only the actions on the workflow page you selected are listed. The selected action is the starting point for the routine.

If you want to verify the location of the routine entry point, click *Go to Entry Point*. The page where the entry point is located opens in the detail view.

5. From the File menu, choose 'Save.' (To cancel the save operation, click *Cancel* on the 'Progress' dialog box.)

This section has explained how to configure the entry point for a routine. The section that follows explains how to change the name of a routine.

Changing the Routine Name

When a routine is created, it is given a default name that includes the routine ID. For example, 'Default Name (16).'

You may change a routine name, but if the routine has already been referenced by other points in workflow, you will be required to;

- Update the properties for the Execute Building Block Routine action. For more information on this action, refer to page 310.
- Update any reference to the routine using a variable.

Note: The *Change Name* button is not available unless you have writing access to the building block. For information on how to change your level of access for a building block, refer to Changing a Building Block Access Level on page 138.

To change the name for a routine:

1. Click *Change Name* on the properties page for the routine.

A warning message appears.

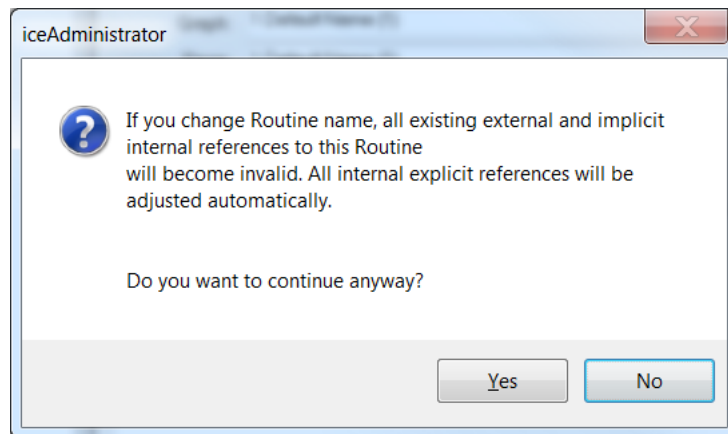

2. Click *Yes* to continue, or click *No* to close this window without making any changes to the routine name.

Upon clicking *Yes*, the 'Change Building Block Routine Name' dialog box appears.

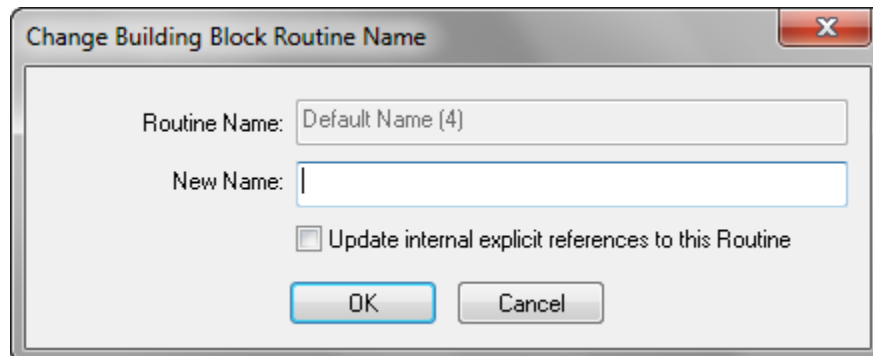

3. Enter the new name for the routine in the 'New Name' field.

The current name for the routine appears in the 'Routine Name' field.

4. Select the 'Update internal explicit references to this Routine' check box if you want to update the explicit references (i.e., not through a variable) to this routine that are found in any Execute Building Block Routine action in this Building Block.

All other references to the routine must be updated manually.

5. Click *OK* to change the routine name and close the dialog box.

Update other portions of workflow that reference the routine, as required.

6. Save your changes From the File menu, choose 'Save.' (To cancel the save operation, click *Cancel* on the 'Progress' dialog box.)

Routine Access: Public or Private

By default, the access to a routine is set to 'Public.'

Public Access:

- A Public routine can be entered from another point in the workflow:
 - From another routine in the same building block,
 - From another routine in a different building block,
 - From a page in the Workflow folder.
- A public routine is entered using the Execute Building Block Routine action.
- For more information on this action, refer to page 310.
- If passwords have been set for the building block:
 - Users with Administrator type or higher can view the properties for routines that have the 'Public' access type,
 - Users cannot view the variables, graphs, or pages for these routines.
 - For more information on building block passwords, refer to page 138.
 - The access to a routine can be changed to 'Private.'

Private Access:

- Private access indicates the routine can only be accessed from other routines within the building block.
- If passwords have been set for the building block:
 - Users are unable to view any information for Private access routines.
 - These routines are not visible in the tree view until a password is entered.
 - For more information on building block passwords, refer to page 138.

Note: You cannot change the access level for a routine unless you have writing access to the building block. For more information, refer to Changing a Building Block Access Level on page 138.

To change the access for the routine:

1. Navigate to the routine that you wish to modify.
2. Click the 'Public' or 'Private' radio button.

The screenshot shows the 'Properties' tab of a dialog box. It contains the following elements:

- Routine Name:** Default Name (4)
- Routine ID:** 4, with a **Change Name** button.
- Access:** Radio buttons for **Public** (selected) and **Private**.
- Routine Entry Point:**
 - Graph:** 1 Default Name (1)
 - Page:** 1 Default Name (1)
 - Action:** (empty dropdown)
- Go To Entry Point** button.
- Summary:** A scrollable text area.

If you changed routine access from the public to private, you might need to update workflow that references the routine.

3. From the File menu, choose 'Save.' (To cancel the save operation, click *Cancel* on the 'Progress' dialog box.)

Adding Arguments

An **argument** is a value that is passed from the originating workflow to the routine. Some examples of values that could be passed to a routine include the originating queue ID, an account number, or an audio message number. Arguments that are required by the routine are added to the routine's Arguments table.

When adding an argument to a routine, you may choose to Pass By Value or Pass By Reference. The default is Pass by Value.

- **Pass by Value:** A copy of the value from the originating workflow is passed to the routine. Changing the value in the routine does not change the value of the originating workflow.
- **Pass by Reference:** A reference to the value from the originating workflow is passed to the routine. Changing the value in the routine also updates the value in the originating workflow.

To add an argument:

The table displays the default value for the variable (if a default value is not set, the 'Default Value' field displays <NONE>) as well as the variable summary. This information is pulled from the variable properties. Double-click a row in the table to jump to the properties for that variable.

Note: All variables in this table are at the Routine level for variable scope.

5. Save your changes From the File menu, choose 'Save.' (To cancel the save operation, click *Cancel* on the 'Progress' dialog box.)

You may need to update workflows that reference the building block routine.

Deleting a Routine

You can delete a routine when it is no longer required. Before deleting the routine, ensure that it is not referenced anywhere else – inside and outside the building block.

Caution: It is highly recommended that you modify workflow outside of regular or peak hours. Place test calls or send test emails or IM messages to your contact center after changes are saved to ensure that workflow is functioning properly.

To delete a routine:

1. Navigate to the routine that you wish to delete and right-click.

A menu appears.

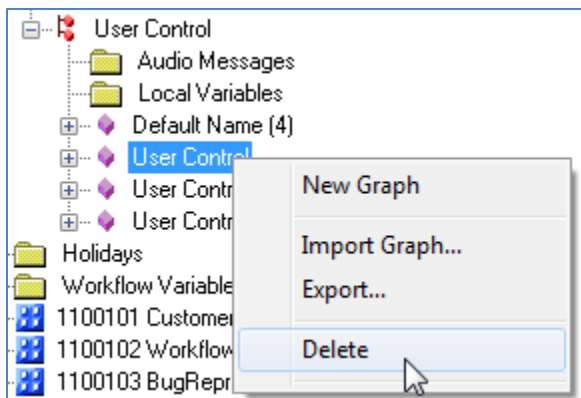

2. Select 'Delete' from the menu.

A message box appears to confirm the removal of the routine.

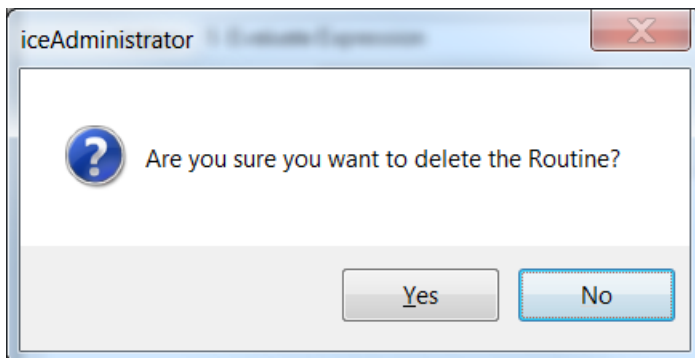

3. Click Yes to delete the routine.

The routine is removed from the building block. Clicking *No* cancels the deletion.

Deleting a Building Block

You can delete a building block when it is no longer required; it can be deleted. Before deleting the building block, ensure that it is not referenced in another building block or anywhere in the workflow.

Caution: It is highly recommended that you modify workflow outside of regular or peak hours. Place test calls or send test emails or IM messages to your contact center after changes are saved to ensure that workflow is functioning properly.

To delete a building block:

1. Navigate to the building block that you wish to delete and right-click.

A menu appears.

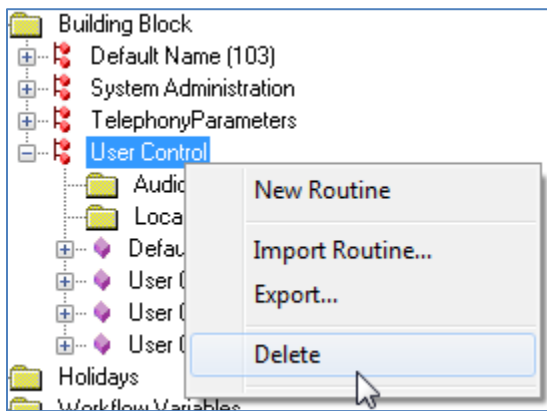

2. Select 'Delete' from the menu.

A message box appears to confirm the removal of the building block.

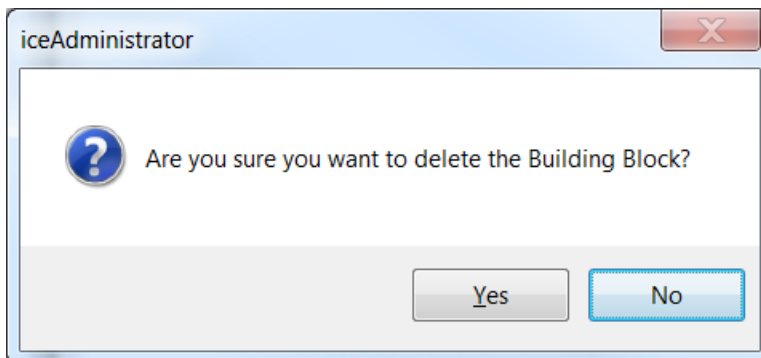

3. Click Yes to delete the building block.

The building block is removed. Clicking *No* cancels the deletion.

Emptying the Building Blocks Folder

You may decide to delete all workflow building blocks to avoid conflict messages when you import building blocks. When you delete all building blocks, you delete all audio messages, variables, and all workflow graphs associated with the building blocks.

Caution: It is highly recommended that you modify workflow outside of regular or peak hours. Place test calls or send test emails or IM messages to your contact center after changes are saved to ensure that workflow is functioning properly.

To delete all building blocks:

1. Right-click on the Building Blocks folder.

A menu appears.

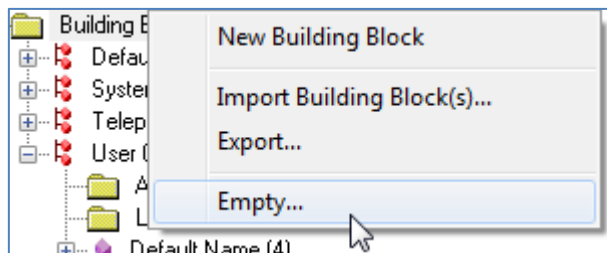

2. Select 'Empty' from the menu.

A message box appears.

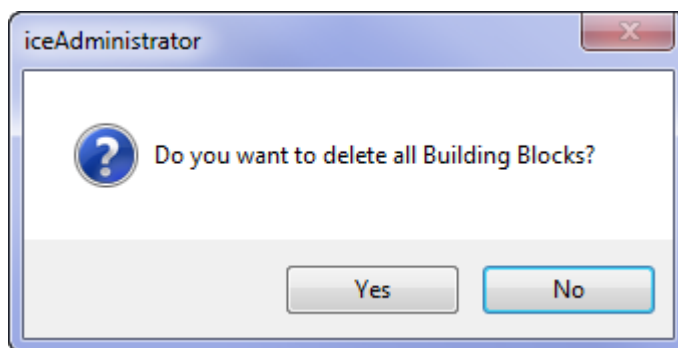

3. Click *Yes* to delete all building blocks. Click *No* to cancel the deletion.
4. From the File menu, choose 'Save.' (To cancel the save operation, click *Cancel* on the 'Progress' dialog box.)



Chapter 6: Standard Actions

Each workflow action has a distinct set of properties that you must complete when you are designing a workflow. When an action is incomplete, its icon appears on the workflow page with a red background. Changes that you have made in iceAdministrator cannot be saved until all actions are completed.





This chapter describes standard workflow actions and their input fields, buttons, checkboxes and radio buttons. Use this chapter as a reference for completing required and optional fields for each standard action type. You may also wish to use this chapter as a reference when modifying standard actions. For more information, refer to the Standard Workflow Actions table for a brief description of each standard action and for a page reference to the appropriate section within this chapter.







This chapter assumes that you are familiar with viewing workflow and that you are working with an existing workflow page. For information on the tasks associated with creating a workflow page and adding actions, refer to Chapter 1: Introduction to Workflow.









Caution: It is highly recommended that you modify workflow outside of regular or peak hours. Place test calls or send test emails or IM messages to your contact center after changes are saved to ensure that workflow is functioning properly.







Standard Workflow Actions Defined

Each ice system comes with standard workflow actions, as described in the table below:

Standard Workflow Actions			
Action	Description	Icon	Page
Assign DN	Assigns a number that can be dialed by a user to enter a particular point in the workflow.		160
Assign Skills to Object	Assigns skills to a contact. Once the contact is queued, it is directed to the user with the best skill set to meet the contact's requirements.		162
Assign Value to Variable	Assigns a value to a variable. You may use this action to initialize a variable or to play a unique message to callers depending on the time of day.		166
Check ANI	Scans for one or more ANI's (Automatic Number Identification), from which the caller has dialed. Callers can be routed to a distinct workflow path based on their ANI. For example, send a caller with a number beginning with 416 (i.e., Toronto callers) to an English queue and send a caller with a number beginning with 514 (i.e., Montreal callers) to a French queue.		171
Check DNIS	Scans for one or more DNIS's (Dialed Number Identification Service) the caller dialed. Callers can be routed to a distinct workflow path based on DNIS. For example, a caller that has dialed (905) 822 5000 is sent to a technical support queue.		174

Standard Workflow Actions			
Action	Description	Icon	Page
Check Time Schedule	Checks the current time against one or more conditions. Contacts can be directed to different workflow paths, based on the result of the check.		177
Comment	Allows a comment to be displayed on a workflow page. This action does not require links to any other action. This action is highlighted in aquamarine on the page so that it is easily visible and distinguishable from other actions.		181
Compare Data	Compares two pieces of data. For example, compare the Estimated Wait Time in two queues to determine the queue to which contacts should be directed.		183
Connector In	Together with Connector Out, this action is used to connect workflow. For example, you can use this to connect workflow on two different pages.		188
Connector Out	Together with Connector In, this action is used to connect workflow. For example, you can use this to connect workflow on two different pages.		190
Dial Digits	This action can 'flash hook' transfer a caller to a number outside of the ice system. This limits the number of lines required if your contact center frequently performs transfers to external numbers. This action can also dial DTMF on the line.		192

Standard Workflow Actions			
Action	Description	Icon	Page
End Workflow Session	Disconnects a caller or creates an end point in workflow for email or instant messages.		226
Evaluate Expression	Evaluates numeric, sting, file or datetime variables (e.g., value z = variable x – variable y). For example, this action can be used to determine a caller's account balance.		194
Get Caller Input	Prompts the caller to enter a series of numbers (e.g., an account number) or a single number (e.g., press 1 for customer service, press 2 for purchasing).		214
Get Queue Status	Stores queue information (e.g., Estimated Wait Time) as a variable. This information can be used later in the workflow to make routing decisions.		221
Link Router	Connects actions on a workflow page.		227
Play Audio File	Plays a message to a caller.		228
Play Music on Hold	Plays standard or custom music to a caller for a specified period of time.		232
Queue Object	Places a contact into a specified queue.		235

Standard Workflow Actions			
Action	Description	Icon	Page
Record Audio File	Prompts a caller to record a message after a tone.		239
Reject Call	Plays ringing, busy tone, or a re-order tone until a caller hangs up. Alternatively, a SIP rejection code can be sent to the SIP phone.		245
Remove Object from Queue	Removes a contact from all queues.		248
Remove Skills from Object	Removes one or all skills from a contact.		250
Route Object	Removes the contact from all queues, and routes that contact to the specified DN. The DN can be a user ID, a number external to ice, or a DN created with the Assign DN action.		252
Set Audio File Base Directory	Sets the Base Directory from which all audio messages should be played from this point in the workflow (e.g., if the caller has selected English, subsequent messages should be played in English).		254
Wait for Incoming Call	Waits for an inbound call. When the call arrives, it is assigned to an object and then routed to the next action. This action is a starting point of workflow for calls.		256

In the section that follows, the options for each of the standard actions are described in detail.

Assign DN

Assign DN creates a number, known as a **DN** (directory number), which acts as an entrance into the workflow. An iceBar user can dial the number to access workflow, or the Route Object action can be used to route contacts to the DN.

The table below provides a description of the fields found on the properties dialog box for Assign DN:

Assign DN	
Option	Description
Action Name	By default, this field shows 'Assign DN.' You can change this by clearing the field and typing a more descriptive name.
Set Default	A button used to generate a new action name based on the properties that you had selected for the action. For Assign DN, the default name is determined by the value of the DN. The action name updates when you click <i>Set Default</i> (e.g., 'DN 6001').
DN	A dropdown list of numbers between 0 and 9999, which can be assigned as the DN. The number selected can be dialed from iceBar. DNs that are in use (i.e., in another Assign DN action or as user IDs) do not appear in the dropdown list.

Assign DN	
Option	Description
Assign to Object	A dropdown list of existing object variables. You can create a new variable by typing the name of the variable directly in to the field or by selecting '<NEW VARIABLE>' from the list. The variable you create is added to the Variables folder in the tree view.
Go To	A dropdown list of all actions that have been placed on the workflow page. Callers are directed to the action selected here when they dial the selected DN.
Link Name	An optional field allowing you to label the link that appears between this action and the action selected from the 'Go To' dropdown list.
Hide Incoming Links	An optional checkbox that allows you to hide the incoming links for this action. For more information, refer to Hiding Incoming Links on page 38.
Log Action	An optional checkbox that allows you to log information about this action. For more information, refer to Logging Activity for an Action on page 44.

Assign Skills to Object

18: Assign Skills to Object

Action Name:

Object:

Skill Type

Level Priority

Skill	Type	Level	Priority
@p_Skill	Discretionary	@p_Level	1

Go To Link Name

Hide Incoming Links
 Log Action

Assign Skills to Object is used to associate skill requirements with a contact. For example, your call center provides support in two languages – English and French. You may want to configure your call center so that callers who make the French language selection to be assigned with the skill French. When the contact is queued, ice finds use that assignment to find the user with the best skill set to handle the contact.

The action allows you to:

- Determine if the skill is Discretionary or Mandatory.
 - At the queue level, thresholds can be enabled that determine when the skill requirement expires (for instances when the queue is busy, and contacts are waiting for a long time).
 - A threshold can be set for discretionary skills, and another threshold can be set for mandatory skills.
 - By default, these thresholds are disabled so that the skill requirement that you set in the Assign Skill action is never removed from the contact.

- **Caution:** Special care must be taken if you disable the discretionary and mandatory skill thresholds at the queue level to ensure that users with the correct skill set are available in the queue.
- Determine the skill level required by the contact.
 - This can be set to a number between 0 and 5, a variable, or to 'Dynamic.'
 - Setting the skill level to 'Dynamic' indicates that, initially, the contact requires the highest level of skill available.
 - At the queue level, a threshold that determines the interval at which ice automatically downgrades the contact's skill requirement by one level can be configured.
 - At each interval, the contact's skill requirement continues to decrease to a minimum of level of 1.
 - If you choose to disable the dynamic downgrade threshold at the queue level, the skill that has been set as dynamic will always require the highest level of skill available in the queue.

In addition to placing the Assign Skills to Object action in workflow, setting up skills-based routing requires:

- 'Ignore Discretionary Skill,' 'Ignore Mandatory Skill,' and 'Dynamic Skill Downgrade' thresholds to be configured at the queue level as required.
- Skills defined in the Skills folder before you add this action to the workflow. All existing skills for your contact center can be found in the 'Skill' dropdown option for Assign Skills to Object.
- Skills assigned to each user. A contact that has been assigned skills is matched to the first available user with the best-matched skill set.

For more information on configuring skill-based routing for your contact center, refer to the *iceAdministrator User Manual*.

The table below describes the fields and buttons found on the properties dialog box for Assign Skills to Object:

Assign Skills to Object	
Option	Description
Action Name	By default, this field shows 'Assign Skills to Object.' You can change this by clearing the field and typing a more descriptive name.
Set Default	A button used to set the default action name. For this action, the name that appears after you click <i>Set Default</i> is 'Assign Skill to Object.'
Object	A dropdown list of existing object variables. Select the object variable that represents the contact to which you wish to assign skills.
Skill	A dropdown list of existing data variables and skills. Select a skill that you wish to assign to the contact from the dropdown list. You may also select a variable that has a skill as a value.
Type	A dropdown list that shows two skill types: discretionary or mandatory.
Level	A dropdown list of data variables, the numbers 0 through 5, and 'Dynamic.' The number selected expresses the minimum level of proficiency that a user must have to answer a contact with a specific skill requirement. Any contact requiring that skill is routed to the user with the best match, provided that the queue's Ignore Skill Threshold has not been reached. A value of 5 represents the highest possible skill level. If you select 'Dynamic,' the contact is simply routed to the user with the highest skill level of all the currently available users in the queues the contact is placed in.
Priority	A number between 0 and 5 expressing the importance of the skill when measured against the skills assigned to the contact. A value of 5 signifies that finding a user who is proficient in this skill is of paramount importance.

Assign Skills to Object	
Option	Description
Add	Once you have created a condition by populating the 'Skill,' 'Type' and 'Level' and 'Priority' fields, use <i>Add</i> to add the condition to the table.
Remove	A button that removes a highlighted skill from the table.
Go To	A dropdown list of all actions that have been placed on the workflow page. Contacts are directed to the action selected here once their skill requirements are assigned.
Link Name	An optional field allowing you to label the link that appears between this action and the action selected from the 'Go To' dropdown list.
Hide Incoming Links	An optional checkbox that allows you to hide the incoming links for this action. For more information, refer to Hiding Incoming Links on page 38.
Log Action	An optional checkbox that allows you to log information about this action. For more information, refer to Logging Activity for an Action on page 44.

Assign Value to Variable

Assign Value to Variable allows you to assign a value to a user-defined variable. Multiple assignments can be made from one Assign Value to Variable action. Consider the following examples:

- You could use this action to initialize a variable. For example, for a contact that has just entered workflow, you might set the value of the variable @badentry to 0. The number of invalid entries the caller makes can then be added to this variable.

Note: The default value for a variable can also be set from the properties of the variable. For more information, refer to page 110.

- You could use this action to set a unique greeting based on the time the call arrives on ice. For example, you can set the value of the variable @greeting to play a morning message to a caller that arrives on ice between 8:00AM and 11:59AM.
- You could use this action to create a data variable containing both text and data from other variables that could be played to a caller, such as a greeting that included the time and the caller's name. For example, in the image above, the variable @Welcome is a greeting variable and is assigned the value "<@NameofCaller> Welcome to XYZ. <@Time>".

The table below describes the fields and buttons found on the properties dialog box for Assign Value to Variable.

Assign Value to Variable	
Option	Description
Action Name	By default, this field shows 'Assign Value to Variable.' You can change this by clearing the field and typing a more descriptive name.

Assign Value to Variable	
Option	Description
Set Default	<p>A button used to generate a new action name based on the properties selected for the action.</p> <p>For this action, the default name is determined by the first row in the Assignments table. The action name is updated when <i>Set Default</i> is clicked. Ellipsis (e.g., 'Set @password to 1234...') indicates that more than one variable is being assigned a value in the Assignments table.</p>
Variable	<p>A dropdown list of existing data variables. You can create a new variable by typing the name of the variable directly in to the field or by selecting '<NEW VARIABLE>' from the list. This variable is added to the Variables folder in the tree view.</p>
Set Default (under the Variable dropdown)	<p>Select this checkbox if you want to reset the value of the variable to the default value. The default value for a variable is set in the properties of the variable. For more information, refer to page 110.</p> <p>The default value does not require initialization by the Assign Value to Variable action and can be changed within the workflow.</p>
Value	<p>The value you are assigning to the variable. This can be a single variable, a string of variables, a static value that you enter, or a combination.</p> <p>This field is not required if the 'Set Default' checkbox has been selected.</p>
Variable/Insert	<p>A dropdown list of existing data variables and system variables. You can create a new variable by selecting '<NEW VARIABLE>' from the dropdown list. Click <i>Insert</i> to add the variable to the 'Value' field above.</p>

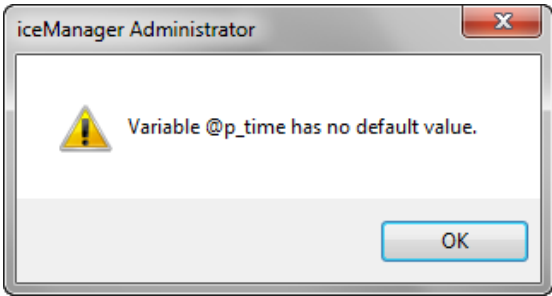
Assign Value to Variable	
Option	Description
Add/Remove	<p>Once you have created the value assignment, click <i>Add</i> to add it to the 'Assignments' table.</p> <p>If you have selected the 'Set Default' checkbox and a default value does not exist for the selected variable, a warning message appears:</p>  <p>Click <i>OK</i> to close the window. The assignment is not added to the table. For information on setting the default value for a variable, refer to page 110.</p> <p>To remove a variable from the list, highlight the desired row, and click <i>Remove</i>.</p>
Up/Down	<p>Buttons used to move a selected row (i.e., an assignment) to a new position in the table. The order of the assignments is important because the assignments are performed from the top down. An assignment in row one may be used to assign a value to a variable in a subsequent row. For example, in the image at the beginning of this section, the variables @p_NameofCaller and @p_time are both assigned values that are used in @p_welcome. @p_welcome must come after @p_NameofCaller and @p_time on the list for the action to work properly.</p>
Go To	<p>A dropdown list of all actions that have been placed on the workflow page. Callers are directed to the action selected here after the specified values have been added to variables.</p>

Assign Value to Variable	
Option	Description
Link Name	An optional field allowing you to label the link that appears between this action and the action selected from the 'Go To' dropdown list.
Hide Incoming Links	An optional checkbox that allows you to hide the incoming links for this action. For more information, refer to Hiding Incoming Links on page 38.
Log Action	An optional checkbox that allows you to log information about this action. For more information, refer to Logging Activity for an Action on page 44.

Check ANI

Automatic Number Identification (ANI) allows ice to see an incoming caller's telephone number or SIP address. Check ANI can give calls a distinct treatment based on a caller's ANI. Consider the following features of the Check ANI action:

- The ANI field is designed to accept an ANI up to 256 characters in length to accommodate dialing patterns in different parts of the world, as well as SIP URIs for VoIP (Voice over IP) calls.
- This action accepts the symbol '?' as a wildcard. For example, you might enter 416??????? in the ANI field if you are scanning for all callers in the Toronto area. The way in which you use wildcards depends on the dialing patterns for your location or the SIP URIs for which you are scanning.

Note: Your contact center's phone lines receive ANI provided that they support ANI/CLID service. Check ANI cannot be used without ANI/CLID service.

30: Check ANI

Action Name:

ANI Go To Link Name

ANI	Go To	Link Name

If No Match Go To: Link Name:

Hide Incoming Links
 Log Action

The table below describes the fields and buttons found on the properties dialog box for Check ANI:

Check ANI	
Option	Description
Action Name	By default, this field shows 'Check ANI.' You can change this by clearing the field and typing a more descriptive name.
Set Default	A button used to set the default action name. For this action, the default name is 'Check ANI.'
ANI	The caller's ANI, or the number they are calling from, can be entered into this field. In North America, ANI is usually ten digits in length, but this field accepts up to 256 digits for SIP URIs. Do not enter spaces, dashes, or brackets when entering the number. The symbol '?' can be used as a wildcard.
Go To	A dropdown list of all actions that have been placed on the workflow page. Callers with the ANI specified in the ANI field are directed to the action selected.
Link Name	An optional field allowing you to label the links that appear between this action and the actions selected from the 'Go To' or the 'If No Match Go To' dropdown lists.
Add	Once you have created a condition by populating the 'ANI' and 'Go To' fields, click <i>Add</i> to add the condition to the table.
Remove	A button used to remove a highlighted condition from the table.
Up /Down	Buttons used to move a selected row (i.e., a condition) to a new position in the table. The order of conditions is important because a search for a matching condition is performed from the top down, and the first matching condition is used to route the caller.
If No Match Go To	A dropdown list of all other actions that are on the same workflow page. Callers are directed to the action you select from this list if their ANI does not match any of the conditions you have added to the table.

Check ANI	
Option	Description
Hide Incoming Links	An optional checkbox that allows you to hide the incoming links for this action. For more information, refer to Hiding Incoming Links on page 38.
Log Action	An optional checkbox that allows you to log information about this action. For more information, refer to Logging Activity for an Action on page 44.

Check DNIS

Dialed Number Identification Service (DNIS) allows ice to see the number or SIP URI (for Voice over IP calls) the caller has dialed. Check DNIS can give calls a distinct treatment based on DNIS.

For traditional calls, DNIS is typically a unique four-digit number that corresponds with the number the caller has actually dialed. For example, if the caller has dialed (905) 882-5500, the DNIS that is passed from the telephone company to ice might be 5500. The DNIS is configurable and may not always match the last four digits of the number actually dialed.

For SIP calls, the DNIS is:

- The SIP URI that the caller has dialed (the 'Request URI'). For example sip:4169878822@icescape.com, or;
- The user portion of the SIP URI. For example, 4169878822.

Consider the following features of the Check DNIS action:

- The 'DNIS' field is designed to accept up to 256 characters. It accepts SIP URI DNISs as well.
- This action accepts the symbol '?' as a wildcard. For example, you might enter 5??? in the 'DNIS' field if you are scanning for callers that dialed a number that passes a DNIS beginning with five, assuming you are expecting to receive a four-digit DNIS.

Note: Your contact center's phone lines receive DNIS provided that they support DNIS service. Check DNIS cannot be used without DNIS service.

The table below describes the fields and buttons found on the properties dialog box for Check DNIS:

Check DNIS	
Option	Description
Action Name	By default, this field shows 'Check DNIS.' You can change this by clearing the field and typing a more descriptive name.
Set Default	A button used to set the default action name. For this action, the default name is 'Check DNIS.'
DNIS	A unique number that corresponds with the number the customer has dialed. The DNIS is often four or ten digits in length, but this field can support up to 256 digits. The DNIS can be typed into this field, or selected from the dropdown list, which displays DNIS's configured in the DNIS folder. Note: It is recommended to select the DNIS from the dropdown list. The DNIS that is added can be tracked in reports. If the DNIS is simply typed into the DNIS field, it will not be included.
Go To	A dropdown list of all actions that have been placed on the workflow page. Callers who dial the DNIS specified in the DNIS field are directed to the action selected here.
Link Name	An optional field allowing you to label the links that appear between this action and the actions selected from the 'Go To' or the 'If No Match Go To' dropdown lists.
Add	Once you have created a condition by populating the 'DNIS,' and 'Go To' fields, click <i>Add</i> to add the condition to the table.
Remove	A button used to remove a highlighted condition from the table.
Up /Down	Buttons used to move a selected row, or condition, to a new position in the table. The order of conditions is important because a search for a matching condition is performed from the top down, and the first matching condition is used to route the caller.

Check DNIS	
Option	Description
If No Match Go To	A dropdown list of all other actions that have been placed on the workflow page. Contacts are directed to the action you select from this list if the number they dialed does not match any of the conditions you have added to the table.
Hide Incoming Links	An optional checkbox that allows you to hide the incoming links for this action. For more information, refer to Hiding Incoming Links on page 38.
Log Action	An optional checkbox that allows you to log information about this action. For more information, refer to Logging Activity for an Action on page 44.

Check Time Schedule

14: Check Time Schedule

Action Name:

On	From	To	Go To	Link Name
Weekday (non-holic)	09:00 AM	05:00 PM		

On	From	To	Go To	Link Name

If No Match Go To:

Hide Incoming Links
 Log Action

Check Time Schedule can give contacts a distinct treatment depending on the day and time that they pass through this action. Consider the following examples of conditions that can be added to the Check Time Schedule table:

- Scan for contacts that arrive on Monday between 8AM and 5PM. Similar conditions can be set up for each day of the week. This option is useful if your contact center has different office hours for each day of the week.
- Scan for contacts that arrive between 7:30AM and 7:30PM on a 'Weekday,' which ice considers as any day between Monday and Friday. This option is useful if your contact center has the same office hours for each day of the week.
- Scan for contacts that arrive between 8AM and 5:30PM on a 'Weekend,' which ice considers as Saturday and Sunday. This option is useful if your contact center has weekend hours that are different from your weekday office hours.
- Scan for contacts that arrive between 6AM and 4:30PM on 'Holidays,' which are days that you have specified in the Holidays folder that is part of the tree view. This option is useful if your contact center wants to handle contacts differently on days that have been defined as holidays.
- Scan for contacts that arrive between 9:30AM and 5:30 PM 'Everyday,' which is any day of the week. This option is useful if your contact center has the same hours of operation regardless of weekday or holidays.

The order of conditions within the Check Time Schedule table is important because a search for a matching condition is performed from the top down, and the first matching condition is used to route the contact.

A default workflow path must be specified if a caller passes through Check Time Schedule at a time that does not match any conditions that you have specified in the Check Time Schedule table.

Special care must be taken when using Check Time Schedule to redirect contacts because of a holiday.

When you add a holiday to the Holidays folder, ice stores the holiday month and date in the database. However, the year is not stored in the database. This is not a concern for holidays that fall on the same day each year (e.g., Canada Day, Independence Day, etc.). However, if the holiday does not have a fixed date (e.g., Easter), you will need to update the holiday each year.

This issue can be resolved by using *Add Date* on the Check Time Schedule action. *Add Date* opens that 'Add Specific Date dialog box, which allows you to add a specific date to the 'On' dropdown list.

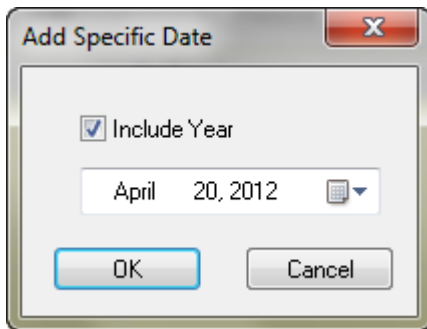

Select the date that you want to add from the dropdown calendar that is part of the dialog box. If you want the year to be saved to the database, check the 'Include Year' checkbox. When you click OK, the date is added to the 'On' dropdown list. You must then add a condition to the 'Check Time Schedule' table for that date, as described in the table below.

Check Time Schedule	
Option	Description
Action Name	By default, this field shows 'Check Time Schedule.' You can change this by clearing the field and typing a more descriptive name.
Set Default	A button used to set the default action name. For this action, the default name is 'Check Time Schedule.'

Check Time Schedule	
Option	Description
On	A dropdown list with the following options: Sunday, Monday, Tuesday, Wednesday, Thursday, Friday, Saturday, Weekday (includes Monday through Friday), Weekend (includes Saturday and Sunday), Everyday (includes every day of the week), and Holiday (holidays are defined in the Holidays folder, as described on page 102).
From	Select a start time.
To	Select an end time.
Go To	A dropdown list of all actions that have been placed on the workflow page. Contacts are directed to this action when they pass through the action on the specified date and time.
Add Date	A button used to add a specific date to the 'On' dropdown list, as described on page 178.
Add	Once you have created a condition by populating the 'On,' 'From,' 'To,' and 'Go To' fields, click <i>Add</i> to add the condition to the table.
Remove	A button that removes a highlighted condition from the table.
Up /Down	Buttons used to move a selected row (i.e., condition), to a new position in the table. The order of conditions is important because a search for a matching condition is performed from the top down, and the first matching condition is used to route the contact.
If No Match Go To	A dropdown list of all other actions that have been placed on the workflow page. Contacts are directed to the action you select from this list if they arrive during a time that does not match any of the conditions you have added to the table.
Link Name	An optional field allowing you to label the links that appear between this action and the actions selected from the 'Go To' or the 'If No Match Go To' dropdown lists.

Check Time Schedule	
Option	Description
Hide Incoming Links	An optional checkbox that allows you to hide the incoming links for this action. For more information, refer to Hiding Incoming Links on page 38.
Log Action	An optional checkbox that allows you to log information about this action. For more information, refer to Logging Activity for an Action on page 44.

Comment

The dialog box titled "20: Comment" contains the following elements:

- Summary:** A text area with a yellow background.
- Comment:** A larger text area for the main comment.
- Applies To:** A dropdown menu.
- Link Name:** A text input field.
- Buttons:** "Add" and "Remove" buttons are positioned between the "Applies To" dropdown and the "Link Name" input.
- Table:** A table with two columns: "Applies To" and "Link Name".
- Footer:** "OK" and "Cancel" buttons.

Comment can be used to insert comments into workflow - comments have no impact on contacts. The action supports outbound links only, which can be used to point to the actions on which you are commenting.

On workflow pages, the Comment action is highlighted in aquamarine so that it is easily visible and distinguishable from other actions:



The table below describes the fields and buttons found on the properties dialog box for Comment:

Comment	
Option	Description
Summary	Enter a summary of the comment in this field, which supports a maximum of 1000 characters. The summary is displayed beneath the action icon on the workflow page.
Comment	Enter the full details of the comment in this field, which supports a maximum of 7000 characters.
Applies To	A dropdown list of all other actions that have been placed on the workflow page. Select the action to which you want to draw a link (e.g., if the action is referenced in the comment).
Add	Once you have selected an action from the 'Applies To' field, click <i>Add</i> to add the action to the table. A link is drawn to each action that is added to the table.
Remove	A button used to remove a highlighted action from the table.
Link Name	An optional field allowing you to label the links that appear between this action and the actions selected from the 'Go To' dropdown lists.

Compare Data

This action compares two pieces of information and uses the result of this comparison to sending a contact on a specific workflow path. Multiple comparisons can be added to the Comparison table, each with its own workflow path.

5: Compare Data

Action Name:

New Comparison

Value Type: Value: Comparison: Value:

Go To: Link Name:

Type	Value	Comparison	Value	Go To	Link Name
Numeric	@bad_entry	equal to	3	4 End Workflow Session	
Numeric	@AccountNumber	greater than	500	6 Play Welcome Message - Regular ...	Regular Customers
Numeric	@AccountNumber	less than	500	2 Play Welcome Message - Priority ...	Priority Customers

Up

If No Match Go To: Link Name:

Hide Incoming Links Log Action

Consider the following examples:

- This action can be used to compare the value of a variable with a static value. For example, you might use this action to determine if the value of variable @bad_entry is equal to 3. Callers who made three “bad entries,” are directed to the End Workflow Session action.
- This action can be used to give special treatment to a caller based on their account number. For example, you can use this action to determine if the caller’s account number is less than 500. Callers with an account number that meets this criterion; they can be directed to a priority queue.

The table below describes the fields and buttons found on the properties dialog box for Compare Data:

Compare Data	
Option	Description
Action Name	By default, this field shows 'Compare Data.' You can change this by clearing the field and typing a more descriptive name.
Set Default	A button used to generate a new action name based on the properties selected for the action. For this action, the default name is determined by the first row in the table. The action name is updated when <i>Set Default</i> is clicked. An ellipsis indicates that more than comparison has been added to the table (e.g., '@bad_entry equal to 3?..').
Value Type	A dropdown list with 'String' or 'Numeric' as the value types. The value type selected determines the type of comparisons available.
Value	Two fields. A dropdown list of existing data variables and system variables. You can create a new variable by selecting '<NEW VARIABLE>' from the list. You may also type a static value in either 'Value' field.
Comparison	A dropdown list of operators that are dependent on the 'Value Type' selected. The operator selected is used to compare the values. For more information, see the tables below.
If Comparison is True Go To	A dropdown list of all other actions that have been placed on the workflow page. The contact is directed to the selected action when the comparison is true.
Add	Once you have created a condition by populating the 'Value Type,' 'Value,' 'Comparison,' and 'If Comparison is True Go To' fields, Click <i>Add</i> to add the condition to the table.
Remove	A button that removes a highlight condition from the table.
Up /Down	Buttons used to move a selected row (i.e., a condition), to a new position in the table. The order of conditions is important because a search for a matching condition is performed from the top down, and the first matching condition is used to route the contact.

Compare Data	
Option	Description
If No Match Go To	A dropdown list of all other actions that have been placed on the workflow page. Contacts are directed to the action you select from this list if there is no match with a comparison in the table (i.e., the comparisons are not true).
Link Name	Optional fields that allow you to label the links that appear between this action and the actions selected from the 'Go To' and 'If No Match Go To' dropdown lists.
Hide Incoming Links	An optional checkbox that allows you to hide the incoming links for this action. For more information, refer to Hiding Incoming Links on page 38.
Log Action	An optional checkbox that allows you to log information about this action. For more information, refer to Logging Activity for an Action on page 44.

When 'Numeric' is the selected value type, the following options are available from the 'Comparison' dropdown list:

Comparison Options for Numeric Value Type	
Comparison	Description
equal to	The first value is equal to the second value. Note: if either value in the comparison is a variable and the variable is not set with a value, the value being compared will be equal to 0. For example: if @varA = 0 and @varB = , then this comparison would pass.
not equal to	The first value is not equal to the second value.
greater than	The first value is greater than the second value.
less than	The first value is less than the second value.
greater than or equal to	The first value is greater than or equal to, the second value.

Comparison Options for Numeric Value Type	
Comparison	Description
less than or equal to	The first value is less than, or equal to, the second value.

When String is the selected value type, the following options are available from the 'Comparison' dropdown list. All comparisons are case sensitive, except where noted:

Comparison Options for String Value Type	
Comparison	Description
equal to	The first value is equal to the second value.
not equal to	The first value is not equal to the second value.
equal to (case-sensitive)	The first value is equal to the second value. This comparison is not case sensitive.
not equal to (case in-sensitive)	The first value is not equal to the second value. This comparison is not case sensitive.
greater than	The first value is greater than the second value.
less than	The first value is less than the second value.
greater than or equal to	The first value is greater than or equal to, the second value.
less than or equal to	The first value is less than, or equal to, the second value.
contains substring	The first value is contained in the second value.
same length as	The first value is equal in length to the second value.
longer than	The first value is longer in length than the second value.
shorter than	The first value is shorter in length than the second value.

Connector In

This action connects workflow that has been created on two workflow pages, or to connect workflow within a page. One 'Connector In' may have links from multiple 'Connector Out's. You can sort the list of 'Connector Outs by graph, page or Connector Out by clicking on the appropriate column heading.

The table below describes the fields and buttons found on the properties dialog box for Connector In:

Connector In	
Option	Description
Action Name	By default, this field shows 'Connector In.' You can change this by clearing the field and typing a more descriptive name.
Set Default	A button used to set the default action name. For this action, the default name is 'Connector In.'
Connected To	This table shows a list of connectors (i.e., Connector Out actions) that terminate on this Connector In.

Connector In	
Option	Description
Go To	A dropdown list of all other actions that are part of the page on which the 'Connector In' has been placed. Contacts are directed to the selected action.
Link Name	An optional field allowing you to label the link that appears between this action and the action selected from the 'Go To' dropdown list.

Connector Out

This action connects workflow that has been created on two workflow pages, or to connect workflow within a page. You must place a 'Connector In' on the workflow page to which you wish to connect. For more information, refer to page 188.

The table below describes the fields and buttons found on the properties dialog box for Connector Out:

Connector Out	
Option	Description
Action Name	By default, this field shows 'Connector Out.' You can change this by clearing the field and typing a more descriptive name.
Set Default	A button used to generate a new action name based on the properties selected for the action. For this action, the default name is determined by ID and name of the workflow page and the ID and name of the Connector In action. The action name updates when <i>Set Default</i> is clicked (e.g., '6 Queue 6001 - 24 To Queue 6001').
Graph	A dropdown list of all other workflow graphs.
Page	A dropdown list of all other workflow pages that are part of the graph you have selected.
Connector In	A dropdown list showing each Connector In that is found on the page you have selected. Contacts will be directed to the selected 'Connector In.'

Connector Out	
Option	Description
Go to Target	Click this button to jump to the selected Connector In. The workflow page opens. The appropriate Connector In action is selected on the workflow page.
Hide Incoming Links	An optional checkbox that allows you to hide the incoming links for this action. For more information, refer to Hiding Incoming Links on page 38.

Dial Digits

Dial Digits can be used to:

- Perform a hook flash transfer. This allows a caller to be transferred to a third party without occupying the second line. The trunks on your system must be configured to allow for a hook flash transfer (e.g., Centrex analogue lines or Robbed Bit T1 that support Hook Flash Transfer). The appropriate access code must be entered when performing a transfer (i.e., 917058287777).
- Dial DTMF. This allows ice to enter in any required DTMF codes when interacting with other automated systems, such as voicemail and IVR units.

The table below describes the characters that can be used with this action:

Dial Digits Characters	
Character	Description
,	Inserts a pause before or between digits.
;	Waits for dial tone before dialing further digits.
!	Dials a flash hook on an analog or Robbed Bit T1 system.

The table below describes the fields and buttons found on the properties dialog box for Dial Digits:

Dial Digits	
Option	Description
Action Name	By default, this field shows 'Dial Digits.' You can change this by clearing the field and typing a more descriptive name.
Set Default	A button used to set the default action name. For this action, the default name is 'Dial Digits.'
Digits to Dial	A dropdown list of existing data variables. You can create a new variable by selecting '<NEW VARIABLE>' from the list. You may also type a static value.
On Success Go To	A dropdown list of all other actions that have been placed on the workflow page. Contacts are directed to the selected action after the specified digits are successfully dialed.
On Dial Failure Go To	A dropdown list of all other actions that have been placed on the workflow page. Contacts are directed to the selected action if the number dialed is invalid.
Link Name	Optional fields that allow you to label the links that appear between this action and the actions selected from the 'On Success Go To' and 'On Dial, Failure Go To' dropdown lists.
Hide Incoming Links	An optional checkbox that allows you to hide the incoming links for this action. For more information, refer to Hiding Incoming Links on page 38.
Log Action	An optional checkbox that allows you to log information about this action. For more information, refer to Logging Activity for an Action on page 44.

Evaluate Expression

This action evaluates numbers, strings, files, or timestamps. Multiple items can be added to the Evaluate Expression table for evaluation.

10: Evaluate Expression

Action Name: Evaluate Expression Set Default

New Expression

Type: Numeric

Action: Generate Random Number between Par1 and Par2

Parameter 1

Parameter 2

Parameter 3

Result

Add Remove

Type	Action	Par1	Par2	Par3	Result

Up Down

Go To Link Name

Hide Incoming Links

Log Action

OK Cancel

Consider the following example of Evaluate Expression in use:

Evaluate Expression might be used to increment a counter. For example, you might use the action to count the number of calls presented to the contact center. Therefore, you must increment a variable each time a call passes through this action (i.e., @numbercalls + 1 = @numbercalls). Each time a caller moves through this action, the @numbercalls variable is increased by one.

The table below describes the fields and buttons found on the properties dialog box for Evaluate Expression:

Evaluate Expression	
Option	Description
Action Name	By default, this field shows 'Evaluate Expression.' You can change this by clearing the field and typing a more descriptive name.
Set Default	A button used to generate a new action name based on the properties selected for the action. For this action, the default name is determined by the first row in the table. The action name is updated when <i>Set Default</i> is clicked. An ellipsis is used to indicate that more than one expression has been added to the table (e.g., "@Balance = @Balance - @Withdrawal..").
Type	A dropdown list with 'String,' 'Numeric,' 'File,' 'Datetime', 'Miscellaneous' as types. The type selected determines operators available in the 'Action' dropdown list.
Action	A dropdown list of operators that are dependent on the 'Type' selected. See the tables below for more information.
Parameter 1 Parameter 2 Parameter 3	A dropdown list of existing data variables, as well as system variables. You can create a new variable by selecting '<NEW VARIABLE>' from the list. You may also type a static value in these fields.
Result	A dropdown list of existing data variables. You can create a new variable by typing the name of the variable directly in to the field or by selecting '<NEW VARIABLE>' from the list. The result of the evaluation is stored in the selected variable.
Add	Once you have created a condition by populating the fields described above, use <i>Add</i> to add the condition to the table.
Remove	A button used to remove a condition from the table. The condition must be highlighted in the table before it can be removed.

Evaluate Expression	
Option	Description
Up/Down	Buttons used to move a selected row (i.e., condition), to a new position in the table. Depending on the use of the action, the order of conditions may be important. For example, you may want to append parameter 2 to parameter 1 before getting the length of the resulting parameter.
Go To	A dropdown list of all other actions that have been placed on the workflow page. The contact is directed to this action after passing through the Evaluate Expression action.
Link Name	An optional field allowing you to label the link that appears between this action and the action selected from the 'Go To' dropdown list.
Hide Incoming Links	An optional checkbox that allows you to hide the incoming links for this action. For more information, refer to Hiding Incoming Links on page 38.
Log Action	An optional checkbox that allows you to log information about this action. For more information, refer to Logging Activity for an Action on page 44.

When 'Numeric' is selected, the following options are available from the 'Action' dropdown list:

Action Options for Numeric Type	
Action	Description
Generate Random Number Between Par1 and Par2	Generates a random number greater or equal to Parameter 1 and less than or equal to Parameter 2.
Integer Result of Par1/Par2	The value of Parameter 1 is divided by the value of Parameter 2, and then the result is truncated to an integer value.

Action Options for Numeric Type	
Action	Description
Is Number (Par 1 – number to validate)	Checks if the value in parameter 1 is numeric.
Maximum (Par1, Par2), Par3 precision	Returns the larger of the two values. Parameter 3 is optionally used to set the number of decimal places the result will be rounded to.
Minimum (Par1, Par2), Par3 precision	Returns the smaller of the two values. Parameter 3 is optionally used to set the number of decimal places the result will be rounded to.
Modulus 10 (Par1 – digits to perform Luhn algorithm on)	Returns the remainder of Parameter 1 after dividing it by 10.
Par1 – Par 2, Par3 precision	The value of Parameter 2 is subtracted from the value of Parameter 1. Parameter 3 is optionally used to set the number of decimal places the result will be rounded to. Examples: If Par1=2.459, Par2=1, and Par3=2 then Result=1.46 If Par1=2.459, Par2=1, and Par3=0 or not set then Result=3
Par1 * Par2, Par3 precision	The value of Parameter 1 is multiplied by the value of Parameter 2. Parameter 3 is optionally used to set the number of decimal places the result will be rounded to.
Par1 / Par2, Par3 precision	The value of Parameter 1 is divided by the value of Parameter 2. This is a floating-point division. Parameter 3 is optionally used to set the number of decimal places the result will be rounded to.
Par1 + Par2, Par3 precision	The value of Parameter 1 is added to the value of Parameter 2. Parameter 3 is optionally used to set the number of decimal places the result will be rounded to.
Par1 Mod Par2	The integer modulus (i.e., the remainder) of Parameter 1 divided by Parameter 2.

Action Options for Numeric Type	
Action	Description
Round Par 1 to Par 2 Decimal Places	<p>The value of Parameter 1 is rounded to the number of decimal places specified in Parameter 2.</p> <p>Examples:</p> <p>If Par1=2.459 and Par2=0, then Result=2</p> <p>If Par1=2.459 and Par2=1, then Result=2.5</p>
Encode Base64 String	<p>Parameter 1 contains the input string to be encoded.</p> <p>Parameter 2 determines if the returned string is the URL safe version. Set Parameter 2 to "1" to enforce URL safe.</p>
Decode Base64 String	<p>Parameter 1 contains the input string to be decoded.</p> <p>Parameter 2 determines if the returned string is the URL safe version. Set Parameter 2 to "1" to enforce URL safe.</p>

When 'String' is selected, the following options are available from the 'Action' dropdown list:

Action Option for String Type	
Action	Description
Append ASCII Character Code in Par 1 to Par 2	<p>ACSCII (American Standard Character Information Interchange) Code provides a numerical representation of a character. The decimal value for the ASCII character is used in Parameter 1. For a list of commonly used characters and the corresponding decimal value, refer to page 204.</p> <p>An example of use in the workflow can be seen in multi-lingual speech recognition applications that use dynamic grammars. For these applications, a grammar string is passed into the Start Speech Recognition action that requires carriage return and line feed. Evaluate Expression can be used to generate the appropriate grammar string.</p> <p>Example for carriage return:</p> <p>If Par1=13, and Par2= RECOGNIZE, then Result=RECOGNIZE <any text that comes after begins on next line>.</p>

Action Option for String Type	
Action	Description
Append Par2 to Par1	<p>Appends Parameter 2 to Parameter 1.</p> <p>Example:</p> <p>If Par1=\$, and Par2=100, then Result=\$100</p>
Convert to Lowercase Par1	<p>Converts all characters to lowercase.</p> <p>Example:</p> <p>If Par1=ABC, then Result=abc</p>
Convert to Uppercase Par 1	<p>Converts all characters to uppercase.</p> <p>Example:</p> <p>If Par1=abc, then Result=ABC</p>
Decode Base64 String	<p>Converts a Base64 encoded string to ASCII string</p>
Encode Base 64 String	<p>Converts an ASCII string to Base64 encoded string.</p>
Escape URL	<p>Converts an ASCII string to URL encoded string.</p>
Get Key	<p>Returns a particular value from a string of key/value pairs that are delimited by a ';' It returns the value of the key specified in Parameter 1. Parameter 2 specifies the instance of the key to return (only useful if the key is repeated in the key/value list). Parameter 3 is the key/value string to be parsed.</p> <p>Example:</p> <p>Par3: firstname=Bob;lastname=Smith;age=12;firstname=Alice;lastname=Bell;age=31</p> <p>If Par1=lastname and Par2=2, then Result=Bell</p>

Action Option for String Type	
Action	Description
Get Length of Par1	<p>Returns the number of characters in a string. For example, can be used to check for valid password length.</p> <p>Examples:</p> <p>If Par1=abc45de, then Result=7</p> <p>If Par1=abc45, then Result=5</p>
Get Substring from Par 1	<p>Returns a substring from Parameter 1. Parameter 2 is used as the starting position, and Parameter 3 determines the length of the substring.</p> <p>Examples:</p> <p>If Par1=Test, Par2=0, and Par3=2, then Result=Te</p> <p>If Par1=Test, Par2=2, and Par3=1, then Result=s</p>
Hash User Password	<p>Returns a password hash value of 32 hexadecimal characters. Parameter 1 is the user's switch ID, parameter 2 is the user's ID, and parameter 3 is the user's password. The result can be compared to the user's actual password, which can be retrieved as a hash value of 32 hexadecimal characters using the User Control action. For more information on this action, refer to page 262.</p> <p>Examples:</p> <p>If Par1=11001, Par2=2001, and Par3=123, then Result= <32 hexadecimal characters stored to variable></p>
Hash User's DTMF Password	<p>Returns a password mapped to a keypad. Non alphanumeric characters are encoded as ' * '.</p>

Action Option for String Type	
Action	Description
Parse Par 1 Using Delimiter from Par 2	<p>Parses Parameter 1 using a delimiter from Parameter 2. (Note: If Parameter 1 is a variable, it is modified to be a new string with the token and the delimiter removed).</p> <p>Examples:</p> <p>If Par1=me;at;here and Par2=; then Result =me and Par1=at;here</p> <p>If Par1=me;at;here and Par 2=* then Result=me;at;here and Par1= <Null></p>

Action Option for String Type	
Action	Description
Parse XML in Par 1 Using an XPath 1.0 query string from Par 2.	<p>Parses Par 1 XML using a Par 2 XPath 1.0 query string. This facilitates parsing of Microsoft Speech Recognition Engine Results in the SML format.</p> <p>Note: The XPath query string provided must return a single item and not a collection of items.</p> <p>XPath samples on available on MSDN: http://msdn.microsoft.com/en-us/library/ms256086.aspx</p> <p>Example:</p> <p>Par1: <SML text=\"Bob Ryan\" utteranceConfidence=\"0.579\" confidence=\"0.579\"> <ext confidence=\"0.472\"> 134 </ext> " <alternate Rank=\"1\" text=\"Bob Ryan\" utteranceConfidence=\"0.579\" confidence=\"0.579\"> \" <ext confidence=\"0.680\"> 134 </ext> " </alternate> " <alternate Rank=\"2\" text=\"Bob Cryan\" utteranceConfidence=\"0.406\" confidence=\"0.406\"> " <ext confidence=\"0.467\"> 135 </ext> " </alternate> " </SML></p> <p>Par2: /SML/alternate[2]/ext/@confidence Result: 0.467</p>
Regular Expression Match	Returns a Boolean '1' or '0' if a direct RegEx match is found.
Regular Expression Replace	Replace all RegEx matches found with provided replacement string.

Action Option for String Type	
Action	Description
Regular Expression Search	Search for all RegEx matches in the provided string. Once a match is found in par2 then par2 is trimmed to contain only the remainder of the string. This allows the subsequent regex search on par2 to find the next match.
Remove Par2 from Par1	Removes Parameter 2 from Parameter 1. Example: If Par1=ababab and Par2=b then Result=aaa
Remove Whitespace from Par 1 from Location Par 2	Removes the whitespace from Parameter 1. Parameter 2 determines how to remove the whitespace, as described below: If Par2=0, then all whitespace is removed If Par2=1, then whitespace to the left is removed. If Par2=2, then whitespace to the right is removed. Examples: If Par1= a b c and Par2=0, then Result =abc If Par1= a b c and Par2=1, then Result=a b c
Search Par 1 for Par 2 and Replace with Par 3	Searches Parameter 1 for Parameter 2 and replace with Parameter 3. Examples: If Par1=ababab, Par2=b, Par3=a, then Result=aaaaaa If Par1=ababab, Par2=ab, Par3=ba, then Result=bababa
Unescape URL	Converts a URL encoded string to an ASCII encoded string.

The following table describes some commonly used ASCII characters and the corresponding decimal value.

ASCII Characters and Decimal Values			
Decimal Value	Character	Decimal Value	Character
010	☐	128	Ç
130	é	131	Â
147	ô	160	Á

When File is selected, the following options are available from the 'Action' dropdown list:

Action Options for File Type	
Action	Description
Check Existence of File Par 1	Verifies the existence of the file specified in Parameter 1. The result equals 0 if the file exists. Otherwise, the result contains a Microsoft Windows® error code.
Copy File Par 1 to Par 2	Copies the file from a directory specified in Parameter 1 to a directory specified in Parameter 2. The result equals 0 if the file is successfully copied. Otherwise, the result contains a Microsoft Windows® error code.
Delete File Par 1	Deletes the file specified in Parameter 1. The result equals 0 if the file is successfully deleted. Otherwise, the result contains a Microsoft Windows® error code.
Find File (Par 1 – directory, Par 2 – pattern)	Queries the file system for the oldest or newest file in a particular directory for a given file-spec.
Get An INI String Value	Retrieve value from INI file for provided section and key combination.
Get Building Block Directory	Retrieves the name of the building block audio message directory based on the building block ID provided. The example shows the result for a building block with ID 100 that is named ConferenceServer. If Par1= 100, then Result = \BBlock\ConferenceServer

Action Options for File Type	
Action	Description
Get File Time	Get file time property. Par1 – file path Par2 – [1=create time, 2=modified time, 3=accesstime]
Get Free Space of Par 1	Retrieves the free space from a drive on the ice server (or another directory on the network to which the ice server has access). The result equals the free space (in bytes). If there is an error in determining the free space, the result equals -1.
Get Size of File Par 1	Determines the size of a file specified in Parameter 1. The result equals the file size (in bytes). If there is an error in determining the file size, the result equals -1.
Make Directory	Makes the directory specified in Parameter 1. The result equals 0 if the directory is successfully created. Otherwise, the result contains a Microsoft Windows® error code.
Read File to Variable	Read string content from a file up to a maximum of 1MB.
Remove Directory	Removes the directory specified in Parameter 1. The result equals 0 if the directory is successfully created. Otherwise, the result contains a Microsoft Windows® error code. Note: The directory must be empty before it can be removed.
Rename File Par 1 to Par2	Renames the file specified in Parameter 1 with the file name specified in parameter 2. The result equals 0 if the file is successfully deleted. Otherwise, the result contains a Microsoft Windows® error code. Note: The new file name (i.e., Parameter 2) must not already exist.

Action Options for File Type	
Action	Description
Save Variable to File	A variable can be appended to an existing file, overwrite the existing file or create a new file with the contents of the variable.
Set An INI String Value	Set value in INI file for provided section and key combination.

When 'Datetime' is selected, the following options are available from the 'Action' dropdown list: For more information about Datetime string as defined for the variable `$System:CurrentDateTime`, refer to page 117.

Action Options for Datetime Type	
Action	Description
Add Datetime	<p>Adds a certain number of units to the provided datetime, where Parameter 1 is the datetime string to be adjusted, Parameter 2 is the duration to be added, and Parameter 3 is the specified unit. (See the 'Add/Subtract Datetime' table on page 212 for a list of the characters used to specify datetime units.)</p> <p>Parameter 1 can be the system variable <code>@System:CurrentDateTime</code>, or a string similarly formatted (yyyy,mm,dd,HH,MM,SS,LLL).</p> <p>Example:</p> <p>Par1=2005,05,24,02,11,26,19,532 Par2=10 Par3=d</p> <p>Resulting in 10 days being added to the date: 2005,06,03,05,11,26,19,532</p>

Action Options for Datetime Type	
Action	Description
Convert C Time	<p>Converts Parameter 1 (C Time, which is the system time and is defined as the number of seconds that have elapsed since midnight on January 1, 1970) to a datetime string in the form:</p> <p>yyyy,mm,dd,dw,HH,MM,SS,LLL</p> <p>Note:</p> <p>Milliseconds will always be set to 000.</p> <p>C Time is represented by the system variable @System:CurrentTime</p>
Create Datetime	<p>Creates a datetime string based on values (Parameter 1) for specified datetime units (Parameter 2). (See the 'Create Datetime' table on page 209 for a list of the characters used to specify datetime units.)</p> <p>Example:</p> <p>Par1=03 24 2005 Par2=%m%d%y</p> <p>Result: 2005,03,24,04,00,00,00,000</p>

Action Options for Datetime Type	
Action	Description
Datetime Difference	<p>Returns the difference between two dates (Parameter 1 and Parameter 2) using the units specified in Parameter 3.</p> <p>Example:</p> <p>Par1=2005,03,01,02,12,00,00,000 Par2=2005,03,14,01,17,45,30,000 Par3=M (where M represents the total difference in minutes)</p> <p>Result: 19065</p> <p>See the 'Datetime Difference' table on page 210 for a list of the characters used to specify datetime units. The 'Example Results' column lists the results that would be expected for each Parameter 3 unit based on the above example.</p>
Format Datetime	<p>Formats a datetime string (Parameter 1) using the format specified in Parameter 2. (See the 'Format Datetime' table on page 211 for a list of the characters used to specify datetime units.)</p> <p>Example:</p> <p>Par1=2005,03,24,04,16,26,19,532 Par2=%B (where %B = full month name)</p> <p>Result: March</p>
Get Current Date/Time	<p>Returns current C time (seconds elapsed since January 1st, 1970 UTC).</p> <p>Par2 indicates whether Daylight Savings is in effect.</p>

Action Options for Datetime Type	
Action	Description
Subtract Datetime	<p>Subtracts a certain number of units from the provided datetime, where Parameter 1 is the datetime string to be adjusted, Parameter 2 is the duration to be subtracted, and Parameter 3 is the specified unit. (For a list of the characters used to specify datetime units, refer to page 212.)</p> <p>Example:</p> <p>Par1=2005,05,24,02,11,26,19,532 Par2=10 Par3=d</p> <p>Resulting in 10 days being subtracted from the current date:</p> <p>2005,05,14,06,11,26,19,532</p>

The following tables describe the characters used to specify units or to format units in the datetime string.

The 'Create Datetime' table lists the characters used to create datetime strings. The Example column lists the units that are created for the following date: Wednesday, March 24, 2012, at 4:26PM (with seconds and milliseconds).

Create Datetime		
Character	Definition	Example
%y or %Y	Year. Note: For the Create Datetime action, the year should always be entered in 4-digit format.	2005
%m	Month.	03
%d	The day of the month.	24

Create Datetime		
Character	Definition	Example
%H	The hour, using 24 hr clock.	16
%M	Minutes.	26
%S	Seconds.	02
%L	Milliseconds.	567

The 'Example' column in the 'Datetime Difference' table below lists the expected result for each Par3 unit (character) based on the following Par1 and Par2 parameters:

Par1=2005,03,01,02,12,00,00,000

Par2=2005,03,14,01,17,45,30,000

Datetime Difference		
Character	Definition	Example
L	Total milliseconds.	1143930000
S	Total seconds.	1143930
M	Total minutes.	19065
H	Total hours.	317
D	Total days.	13
l	The difference in millisecond units only.	0
s	The difference in second units only.	30
m	The difference in minute units only.	45
h	The difference in hour units only	5

The 'Format Datetime' table lists the characters used to specify datetime units for formatting purposes. The 'Example' column shows the resulting format for each unit based on the following datetime string: 2005,08,17,03,16,45,40,000

Format Datetime		
Character	Definition	Example
%a	The abbreviation for the day of the week	Wed
%A	The day of the week.	Wednesday
%b	The abbreviation for the month.	Aug
%B	The name of the month.	August
%c	The date and time format for the locale. For example, mm/dd/yy hh:mm:ss for the United States.	08/17/05 16:45:40
%d	The day of the month in decimal format, ranging from 01 to 31.	17
%H	An hour in 24-hour format The hour of the day, using a 24-hour format.	16
%I	An hour in 12-hour format The hour of the day, using the 12-hour format.	04
%j	The day of the year in decimal format, ranging from 001 to 366.	229
%m	The month of the year in decimal format, ranging from 01 to 12.	08
%M	The minutes in the hour in decimal format, ranging from 00 to 59.	45
%p	The am or pm indicator for the date of the current locale if it is in 12-hour format.	PM
%S	The seconds in the minute in decimal format, ranging from 00 to 59.	40

Format Datetime		
Character	Definition	Example
%U	The week in the year in decimal format, using Sunday as the first day of the week, and ranging from 00 to 53.	33
%w	The day of the week in decimal format, ranging from 0 to 6, where Sunday is 0.	3
%W	The week in the year in decimal format, using Monday as the first day of the week, and ranging from 00 to 53	33
%x	The date formatted for the locale. For example, mm/dd/yy for the United States.	08/17/05
%X	The time formatted for the locale.	16:45:40
%y	The year in decimal format, not including the century, and ranging from 00 to 99.	05
%Y	The year in decimal format, including the century, and ranging from 0000 to 9999.	2005
%z	The time zone.	Eastern Daylight Time
%Z	The abbreviated time zone.	EDT

The 'Add/Subtract' datetime table lists the characters used to specify the datetime units you want to add or subtract.

Add/Subtract Datetime	
Character	Definition
l	Milliseconds.
s	Seconds.
m	Minutes.
h	Hours.

Add/Subtract Datetime	
Character	Definition
d	Days.
d:h:m:s:l	Days:Hours:Minutes:Seconds:Milliseconds Note: The different units can be combined in any order to add or subtract from a datetime string.

When 'Miscellaneous' is selected, the following options are available from the 'Action' dropdown list:

Action Options for Miscellaneous Type	
Action	Description
Decrypt AES	Decrypt AES encrypted string back to plain text.
Encrypt AES	Encrypt plain text string into AES encrypted string.
Generate GUID	Generates a new 128-bit unique identifier. Example: 7fb1185a-ab13-476a-99b4-e331d2fc2c65
GSpeak	Replace the gspeak.dll. Determine the scripts to use when playing back data values like dates, times, amounts, and alphanumeric strings.
Read Server Variable	Retrieves a server variable configured through iceManager or Workflow.
Save Server Variable	Set a server variable given a category and variable name combination.
Sleep	Sleeps current execution for Par1 interval provided in milliseconds.

Get Caller Input

Get Caller Input can be used to prompt callers to enter multiple digits or single digits. Consider the following examples:

- This action can prompt callers to enter multiple digits. You may prompt callers to enter their account number (e.g., "Please enter your 8 digit account number"). The account number entered is saved to the variable that you specify.
- This action can prompt callers to enter single digits. You may prompt callers to make a language selection (e.g., "Press 1 for English, 2 for French"). Based on the digit entered, callers are routed to a distinct workflow path.

6: Get Caller Input X

Action Name: Set Default

General

First Message: Store Caller Input In:

Prompt Message: Intro DTMF Abort Clear Digit Buffer

Digits

Minimum Digits: Terminating Digits:

Maximum Digits: On Terminating Digit Go To:

Valid Digits: Link Name:

Store Terminating Digit In:

Single Digit Response

Digit	Go To	Link Name	Digit	Go To	Link Name	Digit	Go To	Link Name
1	<input type="text"/>	<input type="text" value="1"/>	2	<input type="text"/>	<input type="text" value="2"/>	3	<input type="text"/>	<input type="text" value="3"/>
4	<input type="text"/>	<input type="text" value="4"/>	5	<input type="text"/>	<input type="text" value="5"/>	6	<input type="text"/>	<input type="text" value="6"/>
7	<input type="text"/>	<input type="text" value="7"/>	8	<input type="text"/>	<input type="text" value="8"/>	9	<input type="text"/>	<input type="text" value="9"/>
*	<input type="text"/>	<input type="text" value="*"/>	0	<input type="text"/>	<input type="text" value="0"/>	#	<input type="text"/>	<input type="text" value="#"/>

Invalid Input & Timeout

Number of Retries: Invalid Input Message:

On Invalid Input Go To: Link Name:

First Digit Timeout (ms): Timeout Message:

Inter Digit Timeout (ms): Error DTMF Abort

On Timeout Go To: Link Name:

On Failure Go To: Link Name:

Hide Incoming Links Log Action

Completing General Properties

The general information required for this action is very similar when the action is used to get multiple digit responses or single digit responses from the caller.

The table below describes the fields for the 'General' properties of Get Caller Input:

Get Caller Input General Properties	
Option	Description
Action Name	By default, this field shows 'Get Caller Input.' You can change this by clearing the field and typing a more descriptive name.
Set Default	A button used to generate a new action name, based on the properties selected for the action. For this action, the default name is determined by the first and prompt messages. The action name is updated when <i>Set Default</i> is clicked (e.g., '10000.wav (Greeting), 10005.wav (Prompt)').
First Message	A dropdown list of messages and data variables. A greeting message is usually enabled as the first message (i.e., "You have reached the XYZ Company"). This message is never repeated. If no greeting is required, select '(No Message).'
Prompt Message	A dropdown list of messages and data variables. This message should prompt the caller to enter their selection (i.e., "Please enter your five digit account number after the tone"). If the caller has made no selection or an invalid selection, the caller is prompted with this message again, until the maximum retries threshold is reached. If no prompt is required, select '(No Message).'
Store Caller Input In	A dropdown list of existing data variables. You can create a new variable by typing the name directly in to the field or by selecting '<NEW VARIABLE>' from the list. The digits entered are stored in the specified variable.
Intro DTMF Abort	Enable this feature if you want to allow callers to "key through" the first and prompt messages by entering any DTMF (Dual Tone Multi Frequency) on the telephone. If this feature is disabled, callers must wait until the message is complete before they can begin entering their selection.

Get Caller Input General Properties	
Option	Description
Clear Digit Buffer	Enable this feature to clear any digits that might have been entered in a previous action.
Hide Incoming Links	An optional checkbox that allows you to hide the incoming links for this action. For more information, refer to Hiding Incoming Links on page 38.
Log Action	An optional checkbox that allows you to log information about this action. For more information, refer to Logging Activity for an Action on page 44.

In this section, you have learned to complete the 'General' properties of Get Caller Input. The following section explains how to complete properties when the caller is expected to enter multiple digits.

Completing Properties for Multiple Digit Responses

Get Caller Input can be used to gather multiple digit responses from a caller. For example, you may want callers to enter their account number. If you wish to configure this action for single digit responses, refer to the next section, 'Completing Properties for Single Digit Responses.'

The table below describes the fields and buttons when Get Caller Input requires multiple digit input from the caller:

Get Caller Multiple Digit Responses Properties	
Option	Description
Minimum Digits	Specify the minimum digits the caller can enter (for multiple digit responses, this is greater than 1). When callers enter fewer than the minimum number of digits, they hear the invalid input message.
Maximum Digits	Specify the maximum digits the caller can enter. Additional digits entered by the caller are ignored.

Get Caller Multiple Digit Responses Properties	
Option	Description
Valid Digits	Specify valid digits. By default, this field shows the following digits: '1234567890#*.' When a caller enters an invalid digit, they hear the invalid input message.
Terminating Digits	<p>A dropdown list of existing data variables. You can create a new variable by selecting '<NEW VARIABLE>' from the list. You may also type a static value in this field. The default value is #. No further digits are accepted after the caller has entered the terminating digit(s).</p> <p>Note: The terminating digit fields are only available once a value greater than 1 has been selected for the minimum/maximum digit fields.</p>
On Terminating Digit Go To	A dropdown list of all other actions that have been placed on the workflow page. Contacts are directed to the selected action when they have entered a valid response.
Link Name	An optional field allowing you to label the link that appears between this action and the action selected from the 'On Terminating Digit Go To' dropdown list.
Store Terminating Digit In:	An optional field is allowing you to store the terminating digit that the caller has entered as a variable. You can select a variable from the dropdown list or create a new variable by typing the name of the variable in the field or by selecting '<NEW VARIABLE>' from the list.

In this section, you have learned to complete the properties of Get Caller Input for multiple digit input. For information on completing property options when callers are expected to enter single-digit responses, continue to page 219.

Completing Single Digit Responses Properties

Get Caller Input can be used like a basic auto attendant that requires single digit input from the caller. For example, you may want callers to press 1 for technical support and 2 for customer service.

The table below provides a description of the fields found on the properties dialog box for Get Caller Input when configuring the action for single digit responses:

Get Caller Single Digit Response Properties	
Option	Description
Minimum Digits	This field must be set to 1 to configure single digit responses. Additional digits entered by the caller will be ignored.
Maximum Digits	This field must be set to 1 to configure single digit responses.
Valid Digits	Allows you to specify valid digits. The possible valid digits are displayed by default: '1234567890#*.' When a caller enters an invalid digit, they hear the invalid input message.
Go To	Each valid single digit response has its own 'Go To' dropdown list showing all other actions that have been placed on the workflow page. Callers are directed to the corresponding action when they enter a valid digit. For example, if you prompt the caller to press 1 for support, then you might select an action from the 'Go To' dropdown for this digit that sends the caller to a support queue. If the digit is not valid, the corresponding 'Go To' dropdown list is greyed out.
Link Name	Optional fields that allow you to label the links that appear between this action and the actions selected from the 'Go To' dropdown lists.

In this section, you have learned to complete the 'Single Digit Responses' properties of Get Caller Input. The following section explains how to complete 'Invalid Input & Timeout' properties.

Completing Properties for Invalid Input & Timeout

When a caller enters an invalid response or does not respond, Get Caller Input can be configured to play a message prompting the caller to try again. Get Caller Input allows you to specify the number of times callers are allowed to retry before they are routed to another action.

The table below describes the fields found on the properties dialog box for Get Caller Input for Invalid Input and Timeout:

Get Caller Invalid Input & Timeout Properties	
Option	Description
Number of Retries	Specify the number of times a caller can timeout or make an invalid selection.
Invalid Input Message	A dropdown list of messages and data variables. The message selected should inform the caller that they have made an invalid selection. If no invalid input message is required, select '(No Message).'
On Invalid Input Go To	A dropdown list of all other actions that have been placed on the workflow page. The caller is directed to the selected action when the maximum number of retries has been met, and the last retry was invalid input.
Timeout Message	A dropdown list of messages and data variables. The message selected should inform the caller that their selection was not received. If no timeout message is required, select '(No Message).'
On Timeout Go To	A dropdown list of all other actions that have been placed on the workflow page. The caller is directed to the selected action when the maximum number of retries has been met, and the last retry was a timeout.
On Failure Go To	A dropdown list of all other actions that have been placed on the workflow page. The caller is directed to the action selected from this dropdown list if any of the messages enabled in the action fail to play (e.g., if the message is not recorded).
Link Name	Optional fields that allow you to label the links that appear between this action and the actions selected from the 3 'Go To' dropdown lists in this Properties dialog box.

Get Caller Invalid Input & Timeout Properties	
Option	Description
First Digit Timeout	Specify the number of milliseconds after the prompt message that ice waits for the caller to enter the first digit. The default is 5000ms (i.e., 5 seconds). If the caller does not enter a digit within this time frame, the timeout message is played.
Inter Digit Timeout	Specify the number of milliseconds ice waits between each digit entered for the next digit. The default is 2000ms (i.e., 2 seconds). If numbers already entered constitute valid input, the caller is directed to the action specified in the 'On Terminating Digits Go To' field. Otherwise, the caller hears the 'Invalid Message.'
Error DTMF Abort	Enable this feature if you want to allow callers to key through the invalid and timeout messages by entering any DTMF on their touch-tone telephone.

Get Queue Status

Get Queue Status is used to retrieve information about a queue. This information may then be used to make a decision in the workflow. For example, the information retrieved using Get Queue Status may be used in the workflow to determine if a contact should continue to wait in a queue. For example, if the number of contacts currently waiting in the queue is high, you might try registering the next contact in a different queue).

The table below describes the fields and buttons found on the properties dialog box for Get Queue Status:

Get Queue Status	
Option	Description
Action Name	By default, this field shows 'Get Queue Status.' You can change this by clearing the field and typing a more descriptive name.

Get Queue Status	
Option	Description
Set Default	<p>A button used to generate a new action name based on the properties selected for the action.</p> <p>For this action, the default name is determined by the first row in the table. The action name is updated when <i>Set Default</i> is clicked. An ellipsis indicates that more than one row has been added to the table (e.g., '@Position = 6001 Customer Service, Position in Queue...').</p>
Object	<p>A dropdown list of existing object variables you have already created. Select the object variable that represents the contact that you wish to queue.</p> <p>Caution: It is important to select the correct active object.</p>
Variable	<p>A dropdown list of existing data variables. You can create a new variable by typing the name of the variable into the field or by selecting '<NEW VARIABLE>' from the list. The information retrieved from the queue is stored in the selected variable.</p>
Queue	<p>A dropdown list of existing queues. The workflow looks to the selected queue to retrieve information.</p>
Parameter	<p>A dropdown list of parameters. The parameter selected determines the type of information workflow retrieves from the queue. For more information, refer to the 'Get Queue Status Properties Parameters' table below.</p>
Add	<p>Once you have created a condition by populating the 'Variable,' 'Queue' and 'Parameter' fields, click <i>Add</i> to add the condition to the table.</p>
Remove	<p>A button that removes a highlighted row from the table.</p>
Go To	<p>A dropdown list of all other actions that have been placed on the workflow page. Contacts are directed to the action after the values of variables have been returned.</p>
Link Name	<p>An optional field allowing you to label the link that appears between this action and the action selected from the 'Go To' dropdown list.</p>

Get Queue Status	
Option	Description
Hide Incoming Links	An optional checkbox that allows you to hide the incoming links for this action. For more information, refer to Hiding Incoming Links on page 38.
Log Action	An optional checkbox that allows you to log information about this action. For more information, refer to Logging Activity for an Action on page 44.

The table below describes the parameters available for Get Queue Status:

Get Queue Status Properties Parameters	
Parameter	Description
Age of oldest call	The number of seconds the oldest caller has been waiting in the queue.
Estimated wait time	<p>Estimated wait time (EWT) is equal to the last handled contact's wait time in the queue. However, if the number of users logged on to the queue has changed since this contact was handled, then the following equation is used to determine the EWT:</p> $\text{EWT} = X \text{ multiplied by } (Y \text{ divided by } Z).$ <p>Where X = the last handled contact's wait time.</p> <p>Where Y = the number of users logged on when the last contact was handled.</p> <p>Where Z = the number of users currently logged on.</p>
Estimated wait time (AHT)	<p>Estimated wait time AHT (Average handle time) is calculated using the following equation:</p> $\text{EWT_AHT} = \text{AHT} * (\text{CIQ} - \text{READY_AGENTS}) / \text{BUSY_AGENTS}$ <p>(determined in a sliding window, defaults to 1 hour)</p> <p>where the parameters are defined as follows:</p> <ul style="list-style-type: none"> • CIQ = calls in queue waiting for an agent

Get Queue Status Properties Parameters	
Parameter	Description
	<ul style="list-style-type: none"> AHT = the total time an agent is occupied because of a given contact (call time + hold time + consult time + wrap-up time) READY_AGENTS = agents who are logged on to the queue and ready and idle BUSY_AGENTS = agents logged in to the queue minus READY_AGENTS <p>For a couple of special cases, the formula works as follows:</p> <ol style="list-style-type: none"> If there are more agents in a ready state than calls queued in that queue, then it will return 0. If there are no busy agents (BUSY_AGENTS = 0), then it will return -1.
Grade of Service 1	The Grade of Service 1 for the queue, as determined by the Target ASA 1 selected for the queue.
Grade of Service 2	The Grade of Service 2 for the queue, as determined by the Target ASA 2 selected for the queue.
Number of users logged on	The number of users logged on to the queue.
Number of available users	The number of users logged on to the queue and in the ready state.
Position in Queue	<p>The position of the contact in the queue (e.g., 1st, 2nd, 3rd, etc.). A number is returned to reflect the position in the queue. For example, a value of 1 is returned if the contact is in the first position in the queue. A contact's position number in the queue may decrease if the contact is queued with priority. For more information on priority, refer to the <i>iceAdministrator User Manual</i>.</p> <p>Note: The 'Position in Queue' parameter should not be used in contact centers that deploy skill-based routing. Position in the queue is based on the contact's time in</p>

Get Queue Status Properties Parameters	
Parameter	Description
	queue and is not related to any assigned skills or the availability of qualified users.
Queue size	The number of contacts waiting in the queue.
Queue status	The status of the queue (night, day, or busy). This information is stored in the corresponding variable in the form of a number. The variable contains 1 when the queue is in night mode, 2 when the queue is in day mode, 3 when the queue is in busy mode and 4, if agents are logged on to the queue on a different server, provided the "If Logged On Elsewhere" queue COS is enabled.
Time in Queue	The number of seconds the contact has been waiting in the queue.

End Workflow Session

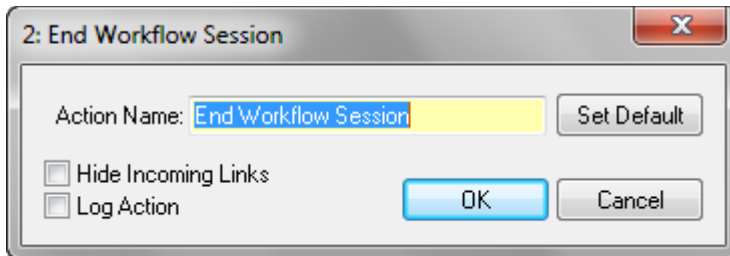

This action disconnects the caller from the system and creates an end point in email and IM workflow. Because this action has no unique properties, it requires no configuration – you simply place the action on the workflow page and create links between other actions and the End Workflow Session action.

The table below describes the fields found on the properties dialog box for End Workflow Session:

End Workflow Session	
Option	Description
Action Name	By default, this field shows 'End Workflow Session.' You can change this by clearing the field and typing a more descriptive name.
Set Default	A button used to set the default action name. For this action, the default name is 'End Workflow Session.'
Hide Incoming Links	An optional checkbox that allows you to hide the incoming links for this action. For more information, refer to Hiding Incoming Links on page 38.
Log Action	An optional checkbox that allows you to log information about this action. For more information, refer to Logging Activity for an Action on page 44.

Link Router

This action facilitates the linking of other actions on a workflow page. Link Router itself has no impact on the contact. The action helps to keep links straight, which is a recommended practice when creating a workflow.

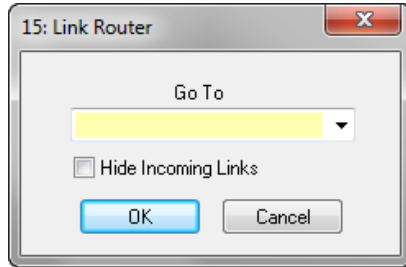

For more information on Link Router, refer to page 40.

The table below describes the fields found on the properties dialog box for Link Router:

Link Router	
Option	Description
Go To	Displays a dropdown list of all other actions that have been placed on the workflow page. Contacts are directed to the selected action.
Hide Incoming Links	An optional checkbox that allows you to hide the incoming links for this action. For more information, refer to Hiding Incoming Links on page 38.

Play Audio File

Play Audio File allows you to play a message to callers. This is usually a message you have already created in the Audio Messages folder, but could also be a variable that has been assigned an audio message as a value.

The table below provides a description of the fields and buttons found on the properties dialog box for Play Audio File:

Play Audio File	
Option	Description
Action Name	By default, this field shows 'Play Audio File.' You can change this by clearing the field and typing a more descriptive name.

Play Audio File	
Option	Description
Set Default	<p>A button used to generate a new action name based on the properties selected for the action.</p> <p>For this action, the default name is determined by the name and description of the message selected. The action name is updated when <i>Set Default</i> is clicked (e.g., '60001.wav (First Queue Message)').</p>
Audio Message	<p>Select an existing message or data variable you have created with a message as the value of the variable. You can create a new audio message or variable by selecting <NEW AUDIO MESSAGE> or <NEW VARIABLE> from the dropdown list.</p> <p>Note: ice supports the playback of WAV, WMA, and MP3 files. Files can also be played using HTTP or HTTPS URLs.</p>
Clear Digit Buffer	<p>Clears any digits that might have been entered in a previous action.</p>
Enable DTMF Abort	<p>Enable this feature if you want to allow callers to "key through" a message. When ice detects DTMF (Dual Tone Multi Frequency), the caller is automatically directed to the action selected in the "Go To" field.</p> <p>Note: DMTF Abort only works if the user presses a key that is not defined as a playback control key in the enable playback control options.</p>
Enable Playback Controls	<p>Enable this checkbox if you want to allow users to control the playback of the audio file. You can let them pause the message, adjust its volume and speed, as well as skip forward and back through it.</p>

Play Audio File	
Option	Description
Speed	<p>The speed changes by 25% each time users press the specified DTMF key. You can select the keys for speed control from the 'Decrease,' 'Reset,' and 'Increase' dropdown lists as necessary. The default for each of these fields is 'NONE' (no user adjustment).</p> <p>Note: Speed control is only available for local (non-HTTP) WMA playback and requires extra telephony resources. This feature must be enabled on your ice system. Please contact ComputerTalk if speed control is not enabled on your ice system.</p>
Skip/ Pause/ Resume	<p>Allows users to adjust their playback position in the audio file. By default, the playback skips forward or backward by 5000ms each time users press the specified DTMF keys, but you can use the scrolling list to select a different skip period. You can select the keys for position control from the 'Skip Backward,' 'Pause/Resume,' and 'Skip Forward' dropdown lists as necessary. The default for each of these fields is 'NONE' (i.e., no user adjustment allowed).</p>
Go To	<p>A dropdown list of all other actions that have been placed on the workflow page. Contacts are directed to the selected action after the message has finished playing.</p>
On Play, Failure Go To	<p>A dropdown list of all other actions that have been placed on the workflow page. Contacts are directed to the selected action if the audio file fails to play (e.g., if the message has not been recorded).</p>
Link Name	<p>Optional fields that allow you to label the links that appear between this action and the actions selected from the 'Go To' dropdown lists.</p>
Hide Incoming Links	<p>An optional checkbox that allows you to hide the incoming links for this action. For more information, refer to Hiding Incoming Links on page 38.</p>

Play Audio File	
Option	Description
Log Action	An optional checkbox that allows you to log information about this action. For more information, refer to Logging Activity for an Action on page 44.

Play Music on Hold

This action plays music to callers, typically after they have been queued with the Queue Object action. In this scenario, the action plays music to callers while they wait in queue for the first available user.

The table below describes the fields and buttons found on the properties dialog box for Play Music on Hold:

Play Music on Hold	
Option	Description
Action Name	By default, this field shows 'Play Music on Hold.' You can change this by clearing the field and typing a more descriptive name.
Set Default	A button used to generate a new action name based on the properties selected for the action. For this action, the default name is determined by the value selected for the duration on hold. The action name is updated when <i>Set Default</i> is clicked (e.g., 'Play Music – 20s').

Play Music on Hold	
Option	Description
Play Music from Broadcaster	<p>By default, this option is selected, and ice's standard on hold music is played to callers when they are presented to this action. When compared to specifying a message to play when callers are presented to Play Music on Hold, enabling 'Play Music from Broadcaster' reduces the use of dynamic resources.</p> <p>Uncheck this option if you plan to use customized music. If not playing from a broadcaster, then the music file must be a WAV, WMA, or MP3 file. The file will play from start to finish and repeat if necessary.</p>
Message Name	If 'Play Music from Broadcaster' is disabled, a WAV, WMA, or MP3 file must be specified from this dropdown list. The file will play from start to finish and repeat if required.
Duration on Hold	A dropdown list allows you to select the number of milliseconds the action plays music to the caller. Selecting 'Infinite' from the list allows music to continue playing until a user answers the caller, or until the caller hangs up. You can also select a variable to represent the length of time the music is played. Select '<NEW VARIABLE>' to create a variable.
Go To	A dropdown list of all other actions that have been placed on the workflow page. Contacts are directed to the action you select from this list after the number of seconds specified in the 'Duration on Hold' field. If the 'Duration on Hold' is set to infinite, this field is greyed out.
Link Name	An optional field allowing you to label the link that appears between this action and the action selected from the 'Go To' dropdown list.
Hide Incoming Links	An optional checkbox that allows you to hide the incoming links for this action. For more information, refer to Hiding Incoming Links on page 38.

Play Music on Hold	
Option	Description
Log Action	An optional checkbox that allows you to log information about this action. For more information, refer to Logging Activity for an Action on page 44.

Note: If Play Music is the first media operation after Wait for Incoming Call and the trunk type is SIP, ringing is heard by the caller instead of music. The next time the action is used in the same workflow (after any other media operation), the caller hears the music.

Queue Object

Queue Object is used to register a contact in a queue, which is a holding place where the caller waits for the first available user. Three distinct workflow paths can be specified based on the status of the queue:

- Day Mode is automatically activated when at least one user logs on to a queue. Alternatively, a queue can be forced into Day Mode when the 'Force Day' feature has been enabled on the queue's properties page. When the queue is in Day Mode, the contact is queued and is directed to the next action.
- Night Mode is automatically activated when all users log out of a queue, provided that the 'Force Day' feature has not been enabled for the queue. When the queue is in Night Mode, the contact is **not** queued and is directed to another action.
- Busy Mode is activated when the number of contacts in the queue is equal to the 'Busy Queue Threshold' that is set on the queue's properties page. When the queue is in Busy Mode, the contact is **not** queued and is directed to another action.

This action can register a contact in one queue at a time, OR when multiple Queue Object actions are used, it can register in multiple queues. Consider the following examples:

- This action can be used to register the caller in a technical support queue. If the queue is in Night Mode or Busy Mode, the action can direct the caller to a second Queue Object action that registers the contact in a technical support backup queue.
- This action can be used to register the caller in a specific queue (e.g., the purchasing queue). After listening to music on hold for thirty seconds, the caller can be directed to a second Queue Object action (e.g., customer service queue). The first available user in either the order desk queue or the customer service queue answers the contact.

The table below describes the fields and buttons found on the properties dialog box for Queue Object:

Queue Object	
Option	Description
Action Name	By default, this field shows 'Queue Object.' You can change this by clearing the field and typing a more descriptive name.
Set Default	A button used to generate a new action name based on the properties selected for the action. For this action, the default name is determined by the queue. The action name is updated when <i>Set Default</i> is clicked (e.g., 'Queue in 6001 Technical Support').
Object	A dropdown list of existing object variables you have already created. Select the object variable that represents the contact that you wish to queue. Caution: It is important to select the correct active object.
Queue	A dropdown list of queues and data variables. Select the queue in which the contact is to be queued.

Queue Object	
Option	Description
With Priority	<p>Allows you to select a level of priority for the contact, which helps determine the contact's position in the queue. The dropdown list allows you to choose a number between 0 and 3600, or an existing data variable. The data variable selected should contain a number that represents the contact's priority level. Note that the value of the variable cannot be greater than 3600.</p> <p>The value you select is used in an equation with 'Priority Weight,' a value that is set on the properties page for each queue. (Priority level) multiplied by (Priority Weight) = Priority (secs), which is the number of seconds that are added to the contact's actual wait time.</p> <p>The contact achieves priority because it appears that they have been waiting for a longer period of time in the queue. For more information, refer to the <i>iceAdministrator User Manual</i>.</p>
Interrupt Workflow/ Do not Interrupt Workflow	<p>Radio buttons allow you to select from two options. The default setting, 'Interrupt Workflow session as soon as the user becomes available,' removes the contact from workflow as soon as a user becomes available.</p> <p>Selecting 'Do not interrupt workflow session unless waiting' directs contacts to an available user only if the contacts are in the Play Music on Hold action.</p>
On Day Mode To	A dropdown list of all other actions that have been placed on the workflow page. Contacts are directed to the action you select when they are successfully registered in the queue.
On Night Mode Go To	A dropdown list of all other actions that have been placed on the workflow page. Contacts are directed to the action you select when the queue is in Night mode.
On Busy Mode Go To	A dropdown list of all other actions that have been placed on the workflow page. Contacts are directed to the action you select when the queue is in Busy mode.

Queue Object	
Option	Description
Link Name	Optional fields that allow you to label the links that appear between this action and the actions selected from the 'Go To' dropdown lists.
Hide Incoming Links	An optional checkbox that allows you to hide the incoming links for this action. For more information, refer to Hiding Incoming Links on page 38.
Log Action	An optional checkbox that allows you to log information about this action. For more information, refer to Logging Activity for an Action on page 44.

Record Audio File

Record Audio File can be used to allow a caller to re-record an audio file that you specify, or to create a new audio file and assign it to a variable. The sections that follow explain how to complete the properties of this action.

28: Record Audio File

Action Name:

Prompt Options

Prompt:

Clear Digit Buffer Enable DTMF Abort

Record Options

Generate unique File Name and assign it to variable:

Use the following File Name:

Maximum Record Time (ms): Abort Tone:

Default Exit Action: Save Cancel

Record Timeout (ms): Silence Time (ms):

Edit Options

Allow Caller to Edit Message

Edit Prompt:

Action	Key	Go To	Link Name
Save:	<input type="text"/>		
Cancel:	<input type="text"/>	<input type="text"/>	<input type="text"/>
Playback:	<input type="text"/>		
Re-record:	<input type="text"/>		

Edit Timeout (msec):

Edit Retries:

	Go To	Link Name
On Success:	<input type="text"/>	<input type="text"/>
On Failure:	<input type="text"/>	<input type="text"/>
On No Voice:	<input type="text"/>	<input type="text"/>

Hide Incoming Links

Log Action

Completing General Properties

'Prompt Options' and other general properties of the Record Audio File action are used to prompt the caller to begin recording and route the caller when the recording is complete.

The table below describes the fields found in the 'Prompt Options' and other general properties for Record Audio File. For information about Record Options and Edit Options, refer to page 90.

Record Audio File Prompt Options Properties	
Option	Description
Action Name	By default, this field shows 'Record Audio File.' You can change this by clearing the field and typing a more descriptive name.
Set Default	A button used to generate a new action name based on the properties selected for the action. For this action, the default name is determined by the name and description of the prompt message selected. The action name is updated when <i>Set Default</i> is clicked (e.g., '10015.wma (Prompt Message)').
Prompt	A dropdown list of messages and data variables. The selected message should prompt the caller to begin recording after the tone. If no prompt is required, select '(No Message).'
Clear Digit Buffer	Enable this feature to clear any digits that might have been entered in a previous action.
Enable DTMF Abort	Enable this feature if you want to allow callers to "key through" the prompt message. When ice detects DTMF (Dual Tone Multi Frequency), the caller hears a beep and can begin recording immediately.
On Success	A dropdown list of all other actions that have been placed on the workflow page. Depending on the configuration of the action, the caller can be directed to the selected action upon entering the abort tone, saving the message, meeting the maximum number of allowable retries, or exceeding the maximum record time.
On Failure	A dropdown list of all other actions that have been placed on the workflow page. The caller is directed to this action if any of the messages fail to play.

Record Audio File Prompt Options Properties	
Option	Description
On No-Voice	A dropdown list of all other actions that have been placed on the workflow page. A contact is directed to this action if a voice is not detected after the prompt message.
Link Name	Optional fields that allow you to label the links that appear between this action and the actions selected from the 'Go To' dropdown lists.
Hide Incoming Links	An optional checkbox that allows you to hide the incoming links for this action. For more information, refer to Hiding Incoming Links on page 38.
Log Action	An optional checkbox that allows you to log information about this action. For more information, refer to Logging Activity for an Action on page 44.

In this section, you have learned to complete the 'Prompt Options' of Record Audio File. The following section explains how to complete the 'Record Options.'

Completing Properties for Record Options

Completing 'Record Options' of the action involves determining how the message is saved, and specifying the maximum length of the recording. The default values of additional 'Record Options' reflect industry standards and are not usually changed.

The table below describes the fields found in the 'Record Options' for Record Audio File:

Record Audio File Record Options Properties	
Option	Description
Generate unique File Name	When this option is selected, a unique File Name is created, and assigned to the variable that you select from the dropdown list. You can create a new variable by typing the name of the variable directly in to the field or by selecting '<NEW VARIABLE>' from the list.

Record Audio File Record Options Properties	
Option	Description
Use the following File Name	Specify an audio message that you have already created or a variable that has been assigned an audio message as its value.
File Type	Specify the file type. Messages are recorded in .wma format. It is recommended that you use the default settings listed here.
Maximum Record Time	Specify the maximum length of a message. The default setting is INFINITE. You can specify the time in seconds or select a variable from the dropdown list. Select '<NEW VARIABLE>' to create a variable. When the maximum record time is exceeded, the caller is directed to the action specified in the 'On Success' dropdown list.
Abort Tone	<p>By default, the abort tone is #. When a caller presses the abort tone, the recording is stopped, and the caller is directed to the action specified in the 'On Success Go To' dropdown list, or to the edit menu if 'Edit Options' are enabled.</p> <p>The dropdown list also allows you to select from the following options: digits 1 through 9, *, or #; ANY; or NONE. Selecting ANY allows the caller to press any digit to stop the recording. Selecting NONE indicates that there is no abort tone. In this scenario, the recording stops when the Record Timeout or Max Record Time is met.</p>
Default Exit Action	Select save or cancel. The selected action is used when callers hang up, or the Edit Timeout is met.
Record Timeout	Specify a maximum number of seconds that ice waits to hear a voice. The default is 5000ms (i.e., 5 seconds). If no voice is detected before the timeout value is reached, the contact is directed to the action specified in the 'On No Voice Go To' dropdown list.

Record Audio File Record Options Properties	
Option	Description
Silence Time	The length of time of silence to allow after a voice has been detected. When this time has expired, the contact is directed to the action specified in the 'On Success Go To' dropdown list. The default value is 'USE DEFAULT,' which is the silence time set in the Record Settings of the Configuration folder in iceAdministrator. This feature can be disabled by selecting 'DISABLE' from the dropdown list.

In this section, you have learned to complete the 'Record Options' of Record Audio File. The following section explains how to complete the optional edit feature of this action.

Completing Properties for Edit Options

This optional feature of Record Audio File can allow callers to edit the message they have just recorded.

Enabling 'Edit Options' affects the functionality of this action. Consider the following:

- When callers enter the abort digit, they hear the prompt message for 'Edit Options.' When 'Edit Options' are disabled, callers are directed to the success action upon entering the abort digit.
- Callers are routed to the success action when they choose to save the recording. Callers are also routed to the success action when they reach the maximum 'Edit Retries' specified for 'Edit Options,' provided that the default exit action is 'Save.'
- Callers are routed to an action you specify when they choose to cancel the recording. Callers are also routed to the 'Cancel' action when they reach the maximum 'Edit Retries' specified for 'Edit Options,' provided that the default exit action is 'Cancel.'
- The recorded message is played back for callers when they select to playback the message. The caller then hears the edit prompt again and can make another selection from the five options.
- Callers hear a beep to indicate they should begin recording again when they select to re-record the message. When finished recording, callers hear the edit prompt again.

- The caller hears a beep to indicate they should begin recording again when they select to append to the message. When finished recording, callers hear the edit prompt again.

The table below describes the fields found in the 'Edit Options' for Record Audio Data:

Record Audio File Edit Options Properties	
Option	Description
Allow Caller to Edit Message	When selected, the caller has the option to edit the message, and the fields described below must be completed.
Edit Prompt	Select a message or a variable that has been assigned an audio file as its value. This message should prompt the caller to save, cancel, play back, re-record, or append to the message (i.e., Press 1 to save, 2 to cancel, etc.). If no edit prompt message is required, select '(No Message)'. If you do not want to give the caller a key option for a particular action, select "NONE" from the dropdown list for that action.
Action/Key	Select a number from the corresponding dropdown lists for each function the caller can use (Save, Cancel, Playback, Re-record, and/or Append). The option to cancel requires that you specify an action from the corresponding 'Go To' dropdown list, which shows all actions that have already been placed on the workflow page. Callers are directed to the selected action when they select the option to Cancel.
Edit Timeout	Specify the number of milliseconds after the prompt message that ice waits for the caller to enter their selection. The default is 2000ms (i.e., 2 seconds). If the caller does not enter a digit within this time, the prompt message is played again.
Edit Retries	Specify the number of times a caller can make an invalid selection and/or timeout. The caller is directed to the action selected from the 'On Success Go To' when the number of retries is met.

Reject Call

Reject Call can play a specific tone to the caller. This action is usually used to prompt the caller to hang up:

- Ringing can be played to callers until they hang up.
- A busy tone can be played to callers until they hang up.
- A re-order tone, or a fast busy, can be played to callers until they hang up.
- A SIP rejection code can be sent from ice to your SIP phone. The SIP phone settings determine the action taken when the rejection code is detected. The call might be ended, or the caller might be transferred to another number.
- For SIP calls, you can specify a 300-level rejection code and specify a URI to which rejected calls are redirected.
- For email messages, you can specify an email address to which rejected emails are redirected.

The table below describes the fields found in the properties dialog box for Reject Call:

Reject Call	
Option	Description
Action Name	By default, this field shows 'Reject Call.' You can change this by clearing the field and typing a more descriptive name.

Reject Call	
Option	Description
Set Default	A button used to set the default action name. For this action, the default name is 'Reject Call.'
Ring until caller hangs up	The caller will hear ringing until he or she hangs up.
Busy until caller hangs up	Play a busy tone until the caller hangs up.
Re-order tone until caller hangs up	Play a re-order tone, or fast busy, until the caller hangs up.
Advanced Rejection	When selected, you must specify a corresponding rejection code.
Rejection Code	A dropdown list of rejection codes that can be sent to the SIP phone, as appropriate. When the SIP phone detects this code, the call is treated accordingly. This field is not available unless 'Advanced Rejection' has been selected above. For email, set this to Advanced Rejection only if you want to terminate the email session via a custom email resolution code.
Custom Code	When '(Custom Reject Reason Code)' is selected from the Rejection Code dropdown list, a number can be selected or typed in this field. For email, you must specify an existing custom email resolution code. If you do not specify an existing custom email resolution code this action will not be complete.

Reject Call	
Option	Description
Redirect Address (SIP URI or e-mail address)	<p>If you have selected 'Advanced Rejection' above, you can specify an email address or SIP URI to which to redirect contact emails or SIP calls.</p> <p>You can type in an address, select a variable from the dropdown list, or create a new variable by selecting '<NEW VARIABLE>' from the list. This field is not available unless 'Advanced Rejection' has been selected above.</p> <p>If you want to redirect SIP calls, select one of the SIP-Redirection rejection codes (in the 300 range) in the 'Rejection Code' dropdown list. If you do not, the 302 rejection code is used by default.</p> <p>If an email address is specified in this field, then any resolution code specified above is ignored. Leave this field empty, if you want the email to be resolved with a custom resolution code.</p>
Hide Incoming Links	<p>An optional checkbox that allows you to hide the incoming links for this action. For more information, refer to Hiding Incoming Links on page 38.</p>
Log Action	<p>An optional checkbox that allows you to log information about this action. For more information, refer to Logging Activity for an Action on page 44.</p>

Remove Object from Queue

Remove Object from Queue is used to remove contacts from all queues in which they are currently waiting.

The table below describes the fields and buttons found on the properties dialog box for Remove Object from Queue:

Remove Object from Queue	
Option	Description
Action Name	By default, this field shows 'Remove Object from Queue.' You can change this by clearing the field and typing a more descriptive name.
Set Default	A button used to generate a new action name based on the properties selected for the action. For this action, the default name is determined by the object. The action name is updated when <i>Set Default</i> is clicked (e.g., 'Remove Object @call from Queue').
Object	A dropdown list of object variables you have already created. Select the object variable that represents the contact you wish to remove from queue.
Go To	A dropdown list of all other actions that have been placed on the workflow page. Contacts are directed to the action you select from the list after being removed from all queues.
Link Name	An optional field allowing you to label the link that appears between this action and the action selected from the 'Go To' dropdown list.

Remove Object from Queue	
Option	Description
Hide Incoming Links	An optional checkbox that allows you to hide the incoming links for this action. For more information, refer to Hiding Incoming Links on page 38.
Log Action	An optional checkbox that allows you to log information about this action. For more information, refer to Logging Activity for an Action on page 44.

Remove Skills from Object

Remove Skills is used to remove one or all skills that have been assigned earlier in the workflow. Contacts with fewer skill requirements have a greater chance of being presented to an available user, but the user may not have the skill set that was originally required. This trade-off might be appropriate for contacts, especially callers, which have been waiting in queue for a long time.

For more information on configuring skills, refer to the *iceAdministrator User Manual*.

The table below describes the fields and buttons found on the properties dialog box for Remove Skills:

Remove Skills from Object	
Option	Properties
Action Name	By default, this field shows 'Remove Skills from Object.' You can change this by clearing the field and typing a more descriptive name.
Set Default	A button used to generate a new action name based on the properties selected for the action. For this action, the default name is determined by the skill that is being removed. The action name is updated when <i>Set Default</i> is clicked (e.g., 'Remove All Skills').
Object	A dropdown list of existing object variables. Select the object variable that represents the contact from which you want to remove skills.

Remove Skills from Object	
Option	Properties
All Skills/Skills	Radio buttons are allowing you to select either 'All Skills' or one 'Skill.' When 'Skill' is selected, you must select a specific skill from the corresponding dropdown list.
Go To	A dropdown list of all other actions that have been placed on the workflow page. Contacts are directed to the action you select from this list after skills are removed.
Link Name	An optional field allowing you to label the link that appears between this action and the action selected from the 'Go To' dropdown list.
Hide Incoming Links	An optional checkbox that allows you to hide the incoming links for this action. For more information, refer to Hiding Incoming Links on page 38.
Log Action	An optional checkbox that allows you to log information about this action. For more information, refer to Logging Activity for an Action on page 44.

Route Object

This action removes contacts from queues they are waiting in and sends the contact to a user, a workflow DN, or an external DN. If the contact is not already queued, then they are simply directed to the specified user or DN.

The table below describes the fields and buttons found on the properties dialog box for Route Object:

Route Object	
Option	Description
Action Name	By default, this field shows 'Route Object.' You can change this by clearing the field and typing a more descriptive name.
Set Default	A button used to generate a new action name based on the properties selected for the action. For this action, the default name is determined by the selected DN. The action name is updated when <i>Set Default</i> is clicked (e.g., 'Route to 4169671111').
Object	A dropdown list of existing object variables. Select the object variable that represents the contact you wish to route or create a new variable by selecting '<NEW VARIABLE>' from the list.

Route Object	
Option	Description
DN	A dropdown list of existing data variables, DNs and user IDs. You may also enter a telephone number in this field.
If DN Not Valid Go To	<p>A dropdown list of all other actions that have been placed on the workflow page. Contacts are directed to the action you select from this list if the Directory Number is not valid or cannot be dialed.</p> <p>If the contact is an email, the contact is directed to this action if the user is not logged on.</p> <p>If the contact is a direct call and that user has 'Disable PAQ Queuing' class of service enabled, the contact is directed to this action if the user is in any state other than Ready.</p>
Link Name	Optional fields that allow you to label the links that appear between this action and the actions selected from the 'If DN Not Valid Go To' dropdown lists.
Hide Incoming Links	An optional checkbox that allows you to hide the incoming links for this action. For more information, refer to Hiding Incoming Links on page 38.
Log Action	An optional checkbox that allows you to log information about this action. For more information, refer to Logging Activity for an Action on page 44.

Note: "," will insert a pause before or between digits.

Set Audio File Base Subdirectory

This action is used in workflow applications that require a particular set of messages.

Consider an application that requires messages to be played in either English or French, depending on the caller's language selection. When creating the messages for the application, you must ensure that each message is added to both base subdirectories. You can then use the Set Audio File Base Subdirectory action to tell workflow which set of messages to use.

For more information on creating audio messages, refer to page 75.

The table below describes the fields and buttons found on the properties dialog box for Set Audio File Base Subdirectory:

Set Audio File Base Subdirectory	
Option	Description
Action Name	By default, this field shows 'Set Audio File Base Subdirectory.' You can change this by clearing the field and typing a more descriptive name.
Set Default	A button used to generate a new action name based on the properties selected for the action. For this action, the default name is determined by the value selected for the base subdirectory. The action name update when <i>Set Default</i> is clicked (e.g., 'Set English').

Set Audio File Base Subdirectory	
Option	Description
Base Subdirectory	A dropdown list of data variables and base subdirectories already created. The base subdirectory you select determines the messages that are played from this point forward in workflow.
Go To	A dropdown list of all other actions that have been placed on the workflow page. Contacts are directed to the action you select from this list.
Link Name	An optional field allowing you to label the link that appears between this action and the action selected from the 'Go To' dropdown list.
Hide Incoming Links	An optional checkbox that allows you to hide the incoming links for this action. For more information, refer to Hiding Incoming Links on page 38.
Log Action	An optional checkbox that allows you to log information about this action. For more information, refer to Logging Activity for an Action on page 44.

Wait for Incoming Call

This action is a starting point for workflow designed for voice calls. This action gathers the information about the caller that is stored in system variables. Captured information can include the number the caller has dialed, the number from which the caller has dialed, and much more. For more information on system variables, refer to page 15.

The table below describes the fields and buttons found on the properties dialog box for Wait for Incoming Call:

Wait for Incoming Call	
Option	Description
Action Name	By default, this field shows 'Wait for Incoming Call.' You can change this by clearing the field and typing a more descriptive name.
Set Default	A button used to set the default action name. For this action, the default name is 'Wait for Incoming Call.'
Assign to Object	A dropdown list of existing object variables. You can create a new variable by typing the name of the variable into the field or by selecting '<NEW VARIABLE>' from the list. The selected object variable will represent each call that passes through this action.
On Success Go To	A dropdown list of all other actions that have been placed on the workflow page. Callers are directed to the action you select from this list.
On Timeout Go To	A dropdown list of all other actions that have been placed on the workflow page. This field is available if you have selected 'Wait for time of' as the wait option.

Wait for Incoming Call	
Option	Description
Link Name	Optional fields that allow you to label the links that appear between this action and the actions selected from the 'On Success Go To' and 'On Timeout Go To' dropdown lists.
Hide Incoming Links	An optional checkbox that allows you to hide the incoming links for this action. For more information, refer to Hiding Incoming Links on page 38.
Log Action	An optional checkbox that allows you to log information about this action. For more information, refer to Logging Activity for an Action on page 44.



Chapter 7: Advanced Actions

Each workflow action has a distinct set of properties that you must complete when designing workflow. When an action is incomplete, its icon appears on the workflow page with a red background. Changes that you have made in iceAdministrator cannot be saved until all actions are completed.







This chapter describes advanced workflow actions and their input fields, buttons, checkboxes and radio buttons. Use this chapter as a reference for completing required and optional fields for each advanced action type. You may also wish to use this chapter as a reference when modifying advanced actions. For more information, refer to the Advanced Workflow Actions table for a brief description of each standard action and for a page reference to the appropriate section within this chapter.









This chapter assumes that you are familiar with viewing workflow and that you are working with an existing workflow page. For information on the tasks associated with creating a workflow page and adding actions, refer to Chapter 1: Introduction to Workflow.

Caution: It is highly recommended that you modify workflow outside of regular or peak hours. Place test calls or send test emails or IM messages to your contact center after changes are saved to ensure that workflow is functioning properly.

Advanced Workflow Actions Defined

Advanced actions are premium actions. Many of them used in Integrated Voice Response (IVR) applications:

Advanced Workflow Actions			
Action	Description	Icon	Page
User Control	Retrieves user settings, sets user properties, and controls user state.		262
Call Web Service	Calls a Web service, which executes a particular operation. The results of the operation can be stored in data variables.		296
Create Auto Dial Request	Creates a new contact and assigns a DN. When a user receives the contact, they automatically dial the DN. This action can be used for applications such as queued voice mail and call back queuing.		302
Get Object User Data	Retrieves information that has been set for the contact.		305
Get Telephony Parameter	Retrieves a low-level telephony parameter.		307
Execute Building Block Routine	Creates an exit point from workflow to a building block routine. This action allows you to set values for the arguments passed into the routine.		322
Execute External Action	Integrates executables, command files or Dynamic-Link Library (DLL) functions into the workflow. For example, you might execute function calls from a DLL to query a database or retrieve information from an initialization file.		313

Advanced Workflow Actions			
Action	Description	Icon	Page
Exit Building Block Routine	Creates an exit point from a building block routine to the originating workflow. This action allows you to set a return value.		322
Make Call	Initiates an outbound call (either as a transfer or as a placed call) and activates call progress monitoring.		323
Obtain Lock	Locks a multi-port variable so that it may be updated before it is accessed by other ports.		323
Output Debug String	Writes a debug string to iceDiagnostics Manager.		323
Release Lock	Releases the lock on a multi-port variable so that it may be accessed by other ports.		335
Set Object User Data	Sets information that can be sent to any CRM application. For example, Execute External Action can be used to retrieve a caller's account number from a database. Set Object User Data can then be used to associate this data with the caller.		340
Set Telephony Parameter	Sets a low-level telephony parameter. For example, set voice recognition telephony parameters.		342
Virtual Workflow	Allows you to initiate and execute workflow applications without an incoming call, email, or IM.		260

User Control

User Control can be used to retrieve user settings (Get Property), set user properties (Set Property), and control a user's state (Issue Command).

The screenshot shows a dialog box titled "26: User Control". It has a close button in the top right corner. The main area contains the following elements:

- Action Name:** A text input field containing "User Control" and a "Set Default" button to its right.
- User ID:** A dropdown menu.
- Action:** A dropdown menu.
- Four additional dropdown menus, each with a downward arrow.
- On Success Go To:** A dropdown menu.
- On Failure Go To:** A dropdown menu.
- Link Name:** Two text input fields, one for each of the "On Success" and "On Failure" dropdowns.
- Hide Incoming Links:** A checkbox.
- Log Action:** A checkbox.
- OK** and **Cancel** buttons at the bottom right.

Consider the following examples:

- **Get Property:** when a caller is transferred to a user's voicemail, User Control can retrieve the user's email address. Workflow can then use this information to send an email notification to inform the user that a caller has been directed to voice mail.
- **Set Property:** to account for instances where users wish to change their properties, User Control allows users to set their passwords and call forwarding settings. It is also used in conjunction with a standard ice voicemail application to set the voicemail count for users.
- **Issue Command:** a workflow application can use User Control to allow you to log users off.

User Control's properties depend on the 'Action' that has been selected (i.e., Get Property, Set Property, or Issue Command). The sections that follow describe the general properties for User Control, and the properties that are specific to Get Property, Set Property, and Issue Command.

General Properties

The table below describes the general fields and buttons found on the properties dialog box for User Control:

User Control General Properties	
Option	Description
Action Name	By default, this field shows 'User Control.' You can change this by clearing the field and typing a more descriptive name.
Set Default	A button used to generate a new action name based on the properties selected for the action. For this action, the default name is determined by the values selected. The action name is updated when <i>Set Default</i> is clicked (e.g., '1000-Logoff').
User ID	A dropdown list of system variables, existing data variables, and existing user IDs. Select the user for which you want to Get Property, Issue Command, or Set Property.
Action	A dropdown list allowing you to select 'Get Property,' 'Issue Command,' or 'Set Property.'
On Success Go To	A dropdown list of all other actions that have been placed on the workflow page. Contacts are directed to the selected action when the properties have been retrieved or set, or the command issued. Note: When issuing a command, the success path is followed when the command is successfully issued to the user's port. Issue Command does not verify that the user's state has actually changed, so workflow must query the user state (using Get Property) sometime, but not immediately after to verify the user is in the desired state.
On Failure Go To	A dropdown list of all other actions that have been placed on the workflow page. Contacts are directed to the selected action if the properties cannot be retrieved or set, or the command is not successfully issued.

User Control General Properties	
Option	Description
Link Name	Optional fields that allow you to label the link that appears between this action and the action selected from the 'On Success Go To' and 'On Failure Go To' dropdown lists.
Hide Incoming Links	An optional checkbox that allows you to hide the incoming links for this action. For more information, refer to Hiding Incoming Links on page 38.
Log Action	An optional checkbox that allows you to log information about this action. For more information, refer to Logging Activity for an Action on page 44.

Get Property

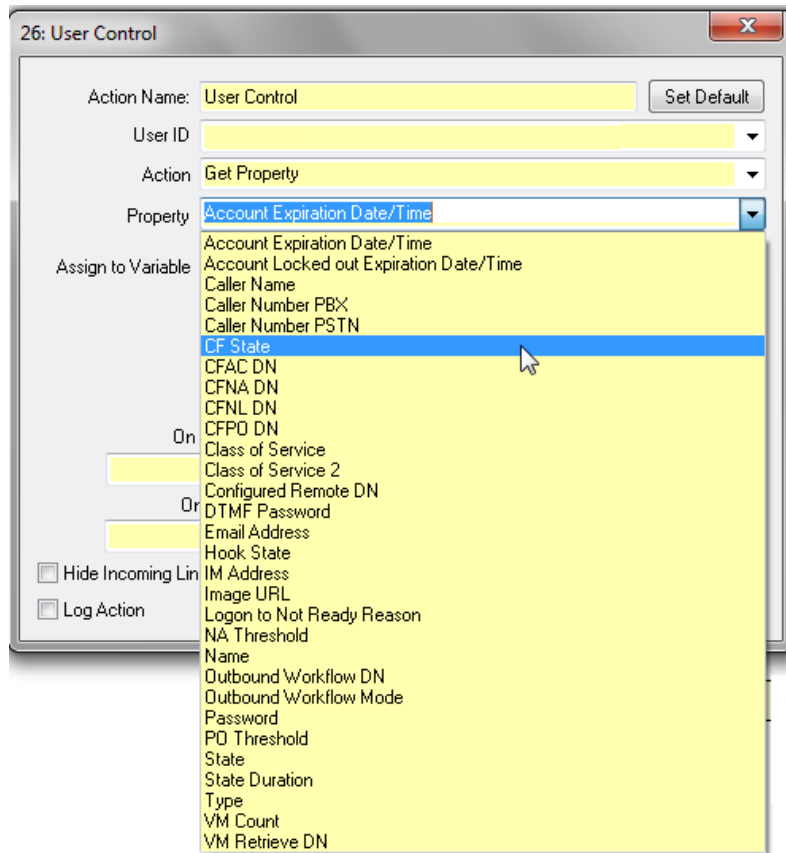

The table below describes the fields that are available when 'Get Property' has been selected for User Control:

Get Property Fields	
Option	Description
Property	A dropdown list of properties that can be retrieved for the selected user. For more information, refer to the Values for Property Field table below.

Get Property Fields	
Option	Description
Assign to Variable	A dropdown list of existing data variables. You can create a new variable by typing the name of the variable directly in to the field or by selecting '<NEW VARIABLE>' from the list. The information retrieved from the queue is stored in the selected variable.

The table below describes the properties that can be selected from the 'Property' field.

Values for Property Field	
Property	Description
Account Expiration Date/Time	Returns the user's account expiration date and time. For more information, refer to the <i>iceAdministrator User Manual</i> .
Account Locked Out Expiration Date/Time	Returns the time when a user is released from an account lockout. For more information, refer to the <i>iceAdministrator User Manual</i> .
Caller Name	Returns 'Name to Send' to PBX or PSTN.
Caller Name PBX	Returns 'Caller Number sent to PBX' for the user's Unified Numbering Plan class of service. For more information, refer to the <i>iceAdministrator User Manual</i> .
Caller Name PSTN	Returns 'Caller Number sent to PSTN/SIP URI' for the user's User Has Direct Inward Dial (DID) Number/SIP URI class of service. For more information, refer to the <i>iceAdministrator User Manual</i> .
CF State	Returns the Call Forward State for a contact that has been call forwarded because of the specified user's call forwarding configuration. This is a bit flag field, meaning that each of the possible values is represented by a hexadecimal number. The value returned is the decimal equivalent of this number.

Values for Property Field	
Property	Description
	<p>The values returned for each call forward state are:</p> <p>1 – Call forwarded as a result of 'Call Forward All Calls.' 16 – Call forwarded as a result of 'Call Forward All Calls.'</p> <p>This code is returned when the VM checkbox has been checked for 'All Calls' in the Call Forwarding configuration for the user.</p> <p>2 – Call forwarded as a result of 'Call Forward No Answer.' 32 – Call forwarded as a result of 'Call Forward No Answer.'</p> <p>This code is returned when the VM checkbox has been checked for 'No Answer' in the Call Forwarding configuration for the user.</p> <p>4 – Call forwarded as a result of 'Call Forward PAQ Overflow.' 64 – Call forwarded as a result of 'Call Forward PAQ Overflow.'</p> <p>This code is returned when the VM checkbox has been checked for 'PAQ Overflow' in the Call Forwarding configuration for the user.</p> <p>8 – Call forwarded as a result of 'Call Forward No Logon.' 128 – Call forwarded as a result of 'Call Forward No Logon.'</p> <p>This code is returned when the VM checkbox has been checked for 'No Logon' in the Call Forwarding configuration for the user.</p>
CFAC DN	Returns the 'Call Forward All Calls' dial number specified for the user. For more information, refer to the <i>iceAdministrator User Manual</i> .
CFNA DN	Returns the 'Call Forward No Answer' dial number specified for the user. For more information, refer to the <i>iceAdministrator User Manual</i> .
CFNL DN	Returns the 'Call Forward No Logon' dial number specified for the user. For more information, refer to the <i>iceAdministrator User Manual</i> .

Values for Property Field	
Property	Description
CFPO DN	Returns the 'Call Forward PAQ Overflow' dial number specified for the user. For more information, refer to the <i>iceAdministrator User Manual</i> .
Class of Service and Class of Service 2	This is a bit flag field. Returns a number that represents the decimal equivalent of the sum of all the hexadecimal numerical codes representing each class of service that has been enabled. For more information, refer to Class of Service on page 278.
Configured Remote DN	Returns the remote dial number configured for the remote user. For more information, refer to the <i>iceAdministrator User Manual</i> .
DTMF Password	Enables users to change the password they would use to log on from their phone.
Email Address	Returns the email address specified for the user. For more information, refer to the <i>iceAdministrator User Manual</i> .
Hook State	Returns the 'Hook State' for the user: 0 – Indicates the user's set is on hook. 1 – Indicates the user's set is off hook.
Image URL	Returns the Image URL that is specified for the user. For more information, refer to the <i>iceAdministrator User Manual</i> .
Logon to Not Ready Reason	Returns the code for the selected Not Ready Reason that is associated with the Logon to Not Ready class of service feature. The default not ready reason codes are: 0 – No Reason 1 – Comfort Break 2 – Post Call Admin Break 3 – Approved Admin Break 4 – Other

Values for Property Field	
Property	Description
	For more information, refer to the <i>iceAdministrator User Manual</i> .
NA Threshold	Returns the 'No Answer Threshold' that is configured for the user. For more information, refer to the <i>iceAdministrator User Manual</i> .
Name	Returns the name configured for the user. For more information, refer to the <i>iceAdministrator User Manual</i> .
Outbound Workflow DN	Returns the outbound workflow DN for the user. For more information, refer to the <i>iceAdministrator User Manual</i> .
Outbound Workflow Mode	Returns the outbound workflow mode for the specified user. The following values are returned for each of the modes: 0 = Disabled 1 = All Calls Placed 2 = All Calls Except Calls to Users 3 = External Calls Only For more information, refer to the <i>iceAdministrator User Manual</i> .
Password	Returns the password configured for the user as a hash value of 32 hexadecimal characters. For more information, refer to the <i>iceAdministrator User Manual</i> .
PO Threshold	Returns the 'PAQ Overflow Threshold' configured for the user. For more information, refer to the <i>iceAdministrator User Manual</i> .
State	Returns a number representing the current state of the user. For a complete list of user states, refer to the 'User States' table below.

Values for Property Field	
Property	Description
State Duration	Returns the total amount of time the user has been in their current state. For more information, refer to the <i>iceAdministrator User Manual</i> .
Type	Returns the user's user type: 1 = User 2 = Team Leader 3 = Supervisor 4 = Administrator 5 = Node Administrator 6 = Site Administrator 7 = Global Administrator
VM Count	Returns the Voicemail count, if it has been configured using the Set Property feature of the User Control action.
Voicemail Retrieve DN	Returns the Voicemail Retrieval DN that is configured for the user. For more information, refer to the <i>iceAdministrator User Manual</i> .

The table below describes each user state and the number that is returned for each state.

User States		
User State	Description	Number Returned
Unknown	User state is unknown. Indicates a possible communication problem between iceBar and the ice server.	0
Logged On	The user is logged on to ice. A user is placed into the Ready or Not Ready state immediately upon logging on, so the duration spent in the Logged On state is minimal.	15

User States		
User State	Description	Number Returned
Logged Off	The user is logged off from ice.	25
Ready	The user is in the Ready state, indicating he or she is available to handle calls from the queue.	35
Not Ready	<p>The user is in the Not Ready state, indicating he or she is unavailable to take calls from the queue.</p> <p>If your contact center uses Not Ready Reasons, the User Not Ready state is returned with the same number, regardless of the Not Ready Reason selected by the user.</p>	55
Wrapup	The user is in the Wrapup state, which occurs after queued calls provided the user has the Wrap Up class of service feature. For more information on Wrapup, refer to the <i>iceAdministrator User Manual</i> .	65
Alerting	A contact is alerting at the user's workstation.	75
Placing Call	The user is initiating a call.	85
On Call	The user is either handling an inbound or outbound call.	105
Consulting	The user is on a consultation call. This allows the user to put his or her caller into a holding state while the user places a call to a third party.	115
Transferring Call	The user is transferring a call.	135
Holding Call	The user has placed a caller on hold.	145
Held	The user is currently on hold (i.e., the user is placed on hold while on a user-to-user call).	165

User States		
User State	Description	Number Returned
Conferencing	The user is on a conference call. This allows the user to have a three-way conversation with the caller and a third party.	175
In Workflow	The user has called a workflow DN.	185
In PAQ	The user is waiting (either alerting or parked) in another user's Personal Access Queue (PAQ).	195
Fast Busy	The user has received a fast busy tone because of a dialing error or other user error.	215
Monitoring	The user is performing Silent Monitoring.	225
On Email	The user is currently in the Email state. A user enters the Email state upon receiving an email message through ice. For more information on handling email messages through iceBar, refer to the <i>iceBar User Manual</i> .	305
On IM	The user is currently in the IM state. A user enters the IM state upon receiving an instant message through ice. For more information on handling IM messages through iceBar, refer to the <i>iceBar User Manual</i> .	315
Picking Ringing Call	The user is using the Pick Ring feature on iceBar to pick a call that is ringing at another iceBar workstation.	405
Picking Held Call	The user is using the Pick Held feature on iceBar to pick a call that has been placed on hold by another iceBar user.	415
Picking Queued Call	The user is using the Pick Queued Call feature on iceBar to retrieve a call that is waiting in a queue from which he or she does not normally take calls.	425

User States		
User State	Description	Number Returned
Picking PAQ Call	The user is using the Pick PAQ feature on iceBar to pick a call out of a PAQ.	435
Swapping PAQ Call	The user is swapping the call he or she is currently handling for a call that is waiting in his or her PAQ.	475
Re-Routing Call	The user is being re-routed. For example, the user is re-routed if he or she calls another user and is then call-forwarded to voicemail.	535

Set Property

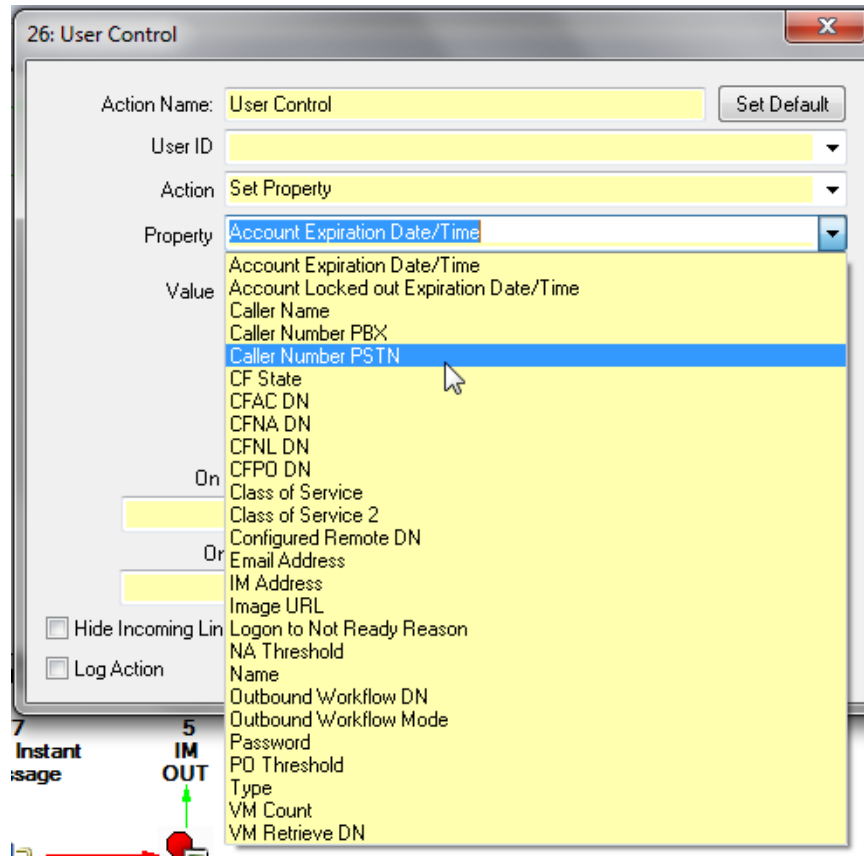

The table below describes the fields that are available when 'Set Property' has been selected for User Control.

Set Property Fields	
Option	Description
Property	A dropdown list of the properties that can be set for the selected user. For a description of these properties, refer to the Values for Property table below.
Value	A dropdown list of existing data variables. You can create a new variable by selecting '<NEW VARIABLE>' from the dropdown list. You can also type in a static value.

The table below describes the properties that can be selected from the 'Property' dropdown list.

Values for Property Field	
Option	Description
Account Expiration Date/Time	Returns the user's account expiration date and time.
Account Locked Out Expiration Date/Time	Returns the time when a user is released from an account lockout. For more information, refer to the <i>iceAdministrator User Manual</i> .
Caller Name	Sets the name to send to PBX or PSTN.
Caller Number PBX	Sets the 'Caller Number sent to PBX' for the user's Unified Numbering Plan class of service.
Caller Number PSTN	Sets the 'Caller Number sent to PSTN/SIP URI' for the user's User Has Direct Inward Dial (DID)/SIP URI Number class of service.
CF State	<p>Enables or disables the Call Forward Calls settings for the specified user. The values used to enable the settings are as follows:</p> <p>1 = All Calls (hexadecimal = 1) 16 = All Calls, Voice Mail enabled (hexadecimal = 10) 8 = No Logon (hexadecimal = 8) 128 = No Logon, Voice Mail enabled (hexadecimal = 80) 2 = No Answer (hexadecimal = 2) 32 = No Answer, Voice Mail enabled (hexadecimal = 20) 4 = PAQ Overflow (hexadecimal = 4) 64 = PAQ Overflow, Voice Mail enabled (hexadecimal = 40)</p> <p>Note: This is a bit flag field. To set more than one CF State at a time, you need to add the hexadecimal equivalents of the values you want to enable and then convert the result back to decimal. For example, to enable 'No Logon, Voice Mail enabled' and 'PAQ Overflow, Voice Mail enabled,' you would add 0x00000080 to 0x00000040, and get C0. 192 is the decimal equivalent. For more information on setting multiple values using hexadecimal numbers, see page 278.</p>

Values for Property Field	
Option	Description
CFAC DN	Sets the Call Forward All Calls DN for the user.
CFNA DN	Sets the Call Forward No Answer DN for the user.
CFNL DN	Sets the Call Forward No Logon DN for the user.
CFPO DN	Sets the Call Forward PAQ Overflow DN for the user.
Class of Service and Class of Service 2	<p>Enables class of service properties for the user. This is a bit flag field. The number you need to enter in the 'Value' field is the decimal equivalent of the hexadecimal sum of all the hexadecimal codes of the properties you want enabled and that is already enabled. If you are only enabling one setting, and no other setting is enabled, you simply use the decimal equivalent of its hexadecimal code. To disable a setting, you must subtract its hexadecimal code from the total of the enabled codes, and enter the decimal equivalent of the result. See page 278 for more information.</p> <p>Note: Some of the class of service settings, such as Email User and Remote User, are found on the user's Properties tab rather than Class of Service tab.</p>
Configured Remote DN	Returns the remote dial number configured for the remote user. For more information, refer to the <i>iceAdministrator User Manual</i> .
Email Address	Sets the email address for the specified user.
IM Address	Sets the IM address for the specified user.
Image URL	Sets the Web Chat image URL for the specified user.
Logon to Not Ready Reason	<p>Sets the Not Ready Reason that is specified when the user logs on to iceBar. You can choose a reason that has been configured or select a variable from the dropdown list.</p> <p>Note: The user must 'Logon to Not Ready' class of service enabled to logon to the selected Not Ready Reason.</p>
NA Threshold	Sets the 'No Answer Threshold' for the specified user.
Name	Sets the name of the user.

Values for Property Field	
Option	Description
Outbound Workflow DN	Sets the outbound workflow DN for the user.
Outbound Workflow Mode	<p>Sets the outbound workflow mode for the specified user. The following values are used for each of the modes:</p> <p>0 = Disabled 1 = All Calls Placed 2 = All Calls Except Calls to Users 3 = External Calls Only</p>
Password	<p>Sets the specified user's password. The password is numeric and must have a minimum of 3 digits and a maximum of 32 digits.</p> <p>To set a new password, click Reset Password. Enter the new password in the 'New Password' field. Re-enter the password in the 'Re-type New Password' field, and click <i>OK</i>.</p>
PO Threshold	Sets the 'PAQ Overflow Threshold' for the specified user.
Type	<p>Allows you to set the user 'Type' configured for the user:</p> <p>1 = User 2 = Team Leader 3 = Supervisor 4 = Administrator 5 = Node Administrator 6 = Site Administrator 7 = Global Administrator</p>
VM Count	Sets the Voice Mail count for a user. It is used in conjunction with the iceVoicemail application.
VM Retrieve DN	Sets the DN for Voice Mail retrieval for the user.

Class of Service

The 'Class of Service' property is available for both the Set Property and the Get Property action.

It is a bit flag field. The value that either you set or that the action returns can represent different settings on the user's 'Properties' tab and 'Class of Service' tab in iceAdministrator. The following table lists the class of service properties that can be set by using the 'Class of Service' property for the Get Property or the Set Property action, as well as the hexadecimal numbers and decimal equivalents that represent them.

To enable a particular setting:

1. Find the hexadecimal number associated with that setting.
2. Add that number to the list of settings (presented in hexadecimal numbers) that are enabled for the user.
3. Add the decimal equivalent of that setting to the 'Value' field on the 'User Control' dialog box.

To disable a particular setting:

1. Subtract the hexadecimal number associated with the setting from the total.
2. Take the decimal equivalent.

The possible combinations are virtually limitless and cannot be listed here.

Note: The decimal numbers for individual properties are only used if you are enabling that one setting and no other settings have been enabled for the user.

The table below provides values for Class of Service.

Class of Service Reference Table		
Class of Service	Hexadecimal Number	Decimal Number
Allow Multiple IM Handling	0x80000000	2147483648
Auto Answer Calls	0x00000800	2048

Class of Service Reference Table		
Class of Service	Hexadecimal Number	Decimal Number
Auto Answer Email or IM	0x40000000	1073741824
Auto Logon	0x04000000	67108864
Disable Auto Not Ready	0x00000080	128
Disable PAQ Queuing	0x00010000	65536
Emergency Contact	0x02000000	33554432
Enable Cleardown	0x00080000	524288
Drop ice User Line Between Calls	0x00800000	524288
Logon to NOT READY	0x00000020	32
Play Dialtone When Off-hook	0x08000000	134217728
Play Call Waiting Tone	0x00000002	2
Remote User	0x10000000	268435456
Password Callback	0x20000000	536870912
Send Name to PBX	0x00004000	16384
Send Name to PSTN/SIP Display Name	0x00008000	32768

Class of Service Reference Table		
Class of Service	Hexadecimal Number	Decimal Number
Silent Monitoring Notification	0x00000200	512
Silent Monitoring Privilege	0x00000100	256
Unified Numbering Plan	0x00001000	4096
User has Direct Inward Dial (DID) Number/SIP URI	0x00002000	8192
Virtual User	0x00000001	1
Wrapup After Placed Call	0x00000040	64
Wrapup After Queued Call	0x00000400	1024

Issue 'Logoff' Command

The Logoff command is used to log the specified user off of one or more queues. When this command is selected, you must select a queue from which to log the user off. The Queue ID dropdown list allows you to select:

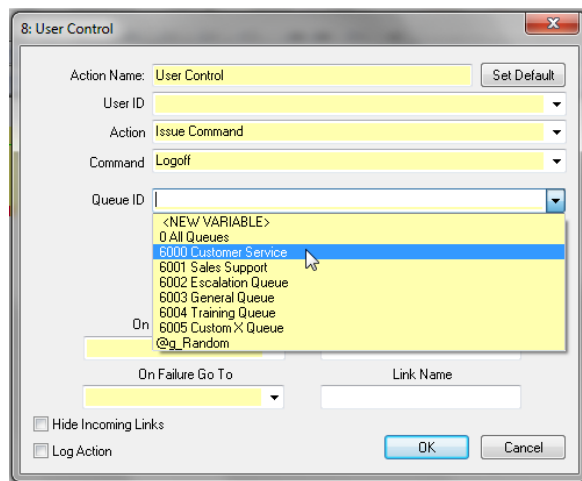

- 0 All Queues: the user will be logged off from all queues upon the success of this action.
- An individual queue that has been created in the Queues folder (e.g., 6001 Technical Support).
- A data variable that has already been created in the Variables folder. A selected variable's value must be a queue ID.

Issue 'Logon' Command

The screenshot shows the '1: User Control' dialog box. The 'Command' dropdown is open, showing a list of commands. 'Logon' is selected. The 'Queue ID' field is empty. The 'On Success Go To' and 'On Failure Go To' fields are also empty. The 'Link Name' fields are empty. The 'Log Action' checkbox is unchecked.

The Logon command is used to log the specified user on to one or more queues. When this command has been selected, the fields described in the table below must be completed.

Logon Command	
Option	Description
Queue ID	A dropdown list allowing you to select '0 All Queues' or one of the existing queues. The user is logged on to the queue that you select. If you select '0 All Queues,' the user is logged on to all queues to which he or she is assigned. You may also select a data variable from the dropdown list, provided that its value is a queue ID.
Password	Enter the user's password, which is required for logon. You may also select a data variable from the dropdown list, provided it has the user's password as its value.

Logon Command	
Option	Description
Remote DN	<p>An optional field allowing you to enter the Remote DN for a remote user. You may also select a data variable from the dropdown list, provided it has the user's Remote DN as its value. A DN entered here overrides the Remote DN configured in the user's profile.</p>
Address ID	<p>Enter the user's address ID. You may also select a data variable from the dropdown list, provided it has the Address ID as its value.</p> <p>For local user workstations, the address ID is a seven-digit number (e.g., 1120021) associated with the station port on ice that is wired to the workstation. If required, press *41 while the ice line is off hook to hear ice read back the address ID for the workstation. You may have to change this number if you are moving your PC to a new workstation.</p> <p>For remote users, the address ID is always 0.</p> <p>For users without a telephone set (i.e., users that receive email only), the address ID is always 1.</p>

Issue 'Place Call' Command

The screenshot shows a dialog box titled "1: User Control" with a close button (X) in the top right corner. The dialog contains the following fields and controls:

- Action Name:** A text box containing "User Control" and a "Set Default" button to its right.
- User ID:** A dropdown menu.
- Action:** A dropdown menu with "Issue Command" selected.
- Command:** A dropdown menu with "Place Call" selected.
- Number to Dial:** A dropdown menu.
- On Success Go To:** A dropdown menu and a "Link Name" text box.
- On Failure Go To:** A dropdown menu and a "Link Name" text box.
- Hide Incoming Links
- Log Action
- OK** and **Cancel** buttons at the bottom right.

The Place Call command is used to initiate a call from the specified user to the number entered in the 'Number to Dial' field. You may also select a data variable from the dropdown list, provided it has the number to dial as its value.

If the user is unavailable to place the call, the action fails and follows the 'On Failure Go To' link.

Note: Local users must be off hook for the Place Call command to be successful.

Issue 'Quick Text' Command

The Quick Text command is used to initiate a quick text message from the user specified in the 'Sending User ID' field to the user specified in the 'User ID' field. When this command has been selected, the fields described in the table below must be completed.

Quick Text Command	
Option	Description
Text	Enter the text to be sent to the selected user. A maximum of 357 characters can be entered in this field. You may also select a data variable from the dropdown list, provided it has the text to be sent as its value.

Quick Text Command	
Option	Description
Priority	<p>A dropdown list allowing you to select the priority of the messages: Emergency (red text), High (blue text), Low (purple text), Normal (black text). The priority selected determines the color of the text when the user receives the Quick Text message. You may also select a data variable that contains a number representing the priority:</p> <p>0 = Normal Priority 1 = Low Priority 2 = High Priority 10 = Emergency Priority</p>
Sending User ID	<p>A dropdown list of user IDs and data variables. Select the user ID that will appear as the sender of the message.</p>

Issue 'Set LOB' Command

1: User Control [X]

Action Name:

User ID

Action

Command

LOBs

On Success Go To

On Failure Go To

Hide Incoming Links

Log Action

The 'Set LOB' command allows the user to tag a Line of Business (LOB) code to a contact in iceWorkflow. Similarly to an agent initiated 'LOB,' issuing the 'LOB' code in iceWorkflow is recorded, and the data is viewable in iceReporting.

2: User Control X

Action Name: Set Default

User ID

Action

Command

LOBs

On

Or

Hide Incoming Lin

Log Action

<NEW VARIABLE>
@%177
@AimAppName
@AppName
@AT_SYMBOL
@BadEntryCounter
@Choice
@CreateAutoDialRequestType
@dialed
@DSN
@FALSE
@G_Cur1BroadcastKeyThruFlag
@G_Cur1BroadcastMsgNumber
@G_Cur2BroadcastKeyThruFlag
@G_Cur2BroadcastMsgNumber
@G_Cur3BroadcastKeyThruFlag
@G_Cur3BroadcastMsgNumber

Issue 'Silent Monitoring' Command

1: User Control [X]

Action Name:

User ID

Action

Command

User ID to Monitor

On Success Go To Link Name

On Failure Go To Link Name

Hide Incoming Links

Log Action

The Silent Monitoring command allows the user specified in the 'User ID' field to Silently Monitor the user entered in the 'User ID to Monitor.' You may also select a data variable from the 'User ID to Monitor' dropdown list, provided it has the user ID of the user to be monitored as its value.

1: User Control

Action Name:

User ID:

Action:

Command:

User ID to Monitor:

On

Or

Hide Incoming Link

Log Action

- <NEW VARIABLE>
- 1001 Team Leader
- 1002 Supervisor
- 1003 Administrator
- 1004 Node Administrator
- 1005 Site Administrator
- 5001 Training Agent 1
- 5002 Training Agent 2
- 5003 Training Agent 3
- 5004 Training Agent 4
- 5005 Training Agent 5
- 9999 Global Admin
- @AimAppName
- @AppName
- @AT_SYMBOL
- @BadEntryCounter
- @Choice
- @CreateAutoDialRequestType
- @dialed
- @DSN
- @FALSE
- @G_Cur1BroadcastKeyThruFlag
- @G_Cur1BroadcastMsgNumber
- @G_Cur2BroadcastKeyThruFlag
- @G_Cur2BroadcastMsgNumber
- @G_Cur3BroadcastKeyThruFlag
- @G_Cur3BroadcastMsgNumber
- @G_Cur4BroadcastKeyThruFlag
- @G_Cur4BroadcastMsgNumber
- @G_Cur5BroadcastKeyThruFlag

If the user specified in the 'User ID' field is unavailable to initiate the monitoring, the action fails and follows the 'On Failure Go To' link.

Note:

- The user specified in the 'User ID' field must have the Silent Monitoring class of service feature enabled, and must be assigned to at least one queue to which the 'User ID to Monitor' is assigned.
- Local users must be off hook for the Silent Monitoring command to be successful.

Issue 'Toggle Ready State' Command

1: User Control [X]

Action Name:

User ID

Action

Command

Not Ready Reason

On Success Go To

Link Name

On Failure Go To

Link Name

Hide Incoming Links

Log Action

The Toggle Ready State command allows the Ready state of the specified user to be toggled. If the user is in the Not Ready state, his or her state is changed to Ready. If the user is in the Ready state, then his or her state is changed to Not Ready.

For users that are toggled from Ready to Not Ready, you have the option of entering a specific number into the 'Not Ready Reason' field, representing the Not Ready state in

which the user should be placed. The numbers that correspond to the default Not Ready Reasons are described below:

- 0 = No Reason
- 1 = Comfort Break
- 2 = Post Call Admin Break
- 3 = Approved Admin Break
- 4 = Other Break

You may also select a data variable, provided it has the number for the Not Ready Reason as its value. If a Not Ready Reason is not specified, then the user is placed in the Not Ready state with "No Reason."

Validate DTMF Password

1: User Control [X]

Action Name:

User ID

Action

Command

Password

On Success Go To

Link Name

On Failure Go To

Link Name

Hide Incoming Links

Log Action

The Validate DTMF Password authenticates values the user enters when logging in from a phone set (i.e., with a touch-tone keypad) against the value or variable in the Password field.

You can also click *Reset Password* to change the password in the workflow to any combination of alphanumeric values that follows the security policies for this switch.

This verifies that the user account meets the following conditions:

- The user is able to logon from a phone set
 - This is configured under the Properties tab for that each user.
- The user account is not locked.
- The user account is not expired.

This command will also track the number of failed attempts to login. This number is sent to the server, so the account can be locked if the maximum attempts have been reached.

The table below provides the Hexadecimal and Decimal numbers that represent different error cases.

Validate the DTMF Password Reference Table		
Error Type	Hexadecimal Number	Decimal Number
Invalid Password Provided	0x01030008	16973832
Account locked	0x01030023	16973859
Password expired	0x01030024	16973860
Password failed, last attempted before account is locked	0x01030025	16973861
Maximum login attempts has been reached	0x01030026	16973862
User not authorized to login from this device	0x01030029	16973865

Validate Password

The screenshot shows a dialog box titled "1: User Control" with a close button (X) in the top right corner. The dialog contains the following fields and controls:

- Action Name:** A text input field containing "User Control". To its right is a "Set Default" button.
- User ID:** A dropdown menu.
- Action:** A dropdown menu containing "Issue Command".
- Command:** A dropdown menu containing "Validate Password".
- Password:** A password input field containing "xxxxxxx". To its right is a "Reset Password" button.
- Below the Password field are three empty dropdown menus.
- On Success Go To:** A dropdown menu.
- On Failure Go To:** A dropdown menu.
- Link Name:** Two empty text input fields, one above the other.
- At the bottom left are two checkboxes: Hide Incoming Links and Log Action.
- At the bottom right are "OK" and "Cancel" buttons.

The Validate Password authenticates values the user enters when logging in against the value or variable in the Password field.

You can also click *Reset Password* to change the password in the workflow to any combination of alphanumeric values that follows the security policies for this switch.

This verifies that the user account meets the following conditions:

The user account is not locked.

The user account is not expired.

This command will also track the number of failed attempts to login. This number is sent to the server, so the account can be locked if the maximum attempts have been reached.

The table below provides the Hexadecimal and Decimal numbers that represent different error cases.

Validate Password Reference Table		
Error Type	Hexadecimal Number	Decimal Number
Invalid Password Provided	0x01030008	16973832
Account locked	0x01030023	16973859
Password expired	0x01030024	16973860
Password failed, last attempted before account is locked	0x01030025	16973861
Maximum login attempts has been reached	0x01030026	16973862

Call Web Services

4: Call Web Services X

Action Name: Set Default

URI:

Credentials

User Name: Password: Use Variable

Domain:

URI	User Name	Password	Domain

Routine Name:

Inputs

Name: Value:

Name	Value

Outputs

Name: Variable:

Name	Variable

Timeout (ms):

Go To: Link Name:

On Failure Go To: Link Name:

Hide Incoming Links Log Action

Call Web Services allows you to connect to, post information to, and receive information from a Web service.

Example: you may want to call a Web service that retrieves caller information from a customer's business database using the function that the customer's Web server would use to get this information. You can create any custom programming logic required for a customer by using Web services, and you can access Web services by using this action. The information that you either send or receive is stored in data variables.

The Call Web Services action allows you to enter input values and then store the output received from the Web service into variables.

Example: the Web service in question can be designed to calculate the sum of two numbers – ‘Number1’ and ‘Number2,’ and return the answer, ‘Sum.’ You could enter two numbers into the ‘Inputs’ section: The first number as ‘Number1’ and with a value of 2, and the second number as ‘Number2’ with a value of 5. The Web service would perform the calculation and return the number 7. You would need to create an entry in the ‘Outputs’ section to hold this value. In this example, you would name it ‘Sum’ and then assign a variable to the value returned from the Web service.

Note:

- WSDL (Web Service Description Language) is used to describe the functions/methods exposed by a Web service, and the input and output parameters of each of these methods.
- If you have access to the Web service URI during workflow development, you can use the ‘Parse WSDL’ feature in order to obtain this information from the Web service.
- The fields in the Call Web Service properties dialog box will be populated based on this information.
- Flattened, segmented, and single WSDL files are supported.
- Complex types and output types are supported.
- WCF Services based on BasicHttpBinding is supported. Specifically, it supports WS-Basic Profile conformant Web services, for example, ASP.NET Web services (ASMX)-based services. The BasicHttpBinding uses HTTP as the transport and text/XML as the default message encoding.
- WSHTTP binding and RESTful services are not supported in this release.

You can provide a list of URIs for the Web Service for redundancy. If ice cannot contact the first URI in the list, it attempts to contact the second, and so on.

Call Web Services	
Option	Description
Action Name	By default, this field shows ‘Call Web Service.’ You can change this by clearing the field and typing a more descriptive name.
Set Default	A button used to set the default action name. For this action, the default name is ‘Call Web Service.’

Call Web Services	
Option	Description
URI	The URI (Universal Resource Identifier) of the Web service WSDL file. You can type in the name, select a variable from the dropdown list or create a new variable by selecting '<NEW VARIABLE>' from the list.
User Name	The user name for the Web service, if required. You can type in the user name, select a variable from the dropdown list or create a new variable by selecting '<NEW VARIABLE>' from the list.
Domain	The domain for the Web service, if required. You can type in the domain, select a variable from the dropdown list or create a new variable by selecting '<NEW VARIABLE>' from the list.
Password	The password for the Web service, if required. You can type in the password, or select the user variable checkbox. When using a variable, you can select from the dropdown list or create a new variable by selecting '<NEW VARIABLE>' from the list.
Add/Remove	Once you have entered a value in the URI field, click <i>Add</i> to add it to the URI list. To remove a variable from the list, highlight the desired row, and click <i>Remove</i> .
Up/Down	Buttons used to move a selected row, or condition, to a new position in the table. Make sure you list the URIs in order of preference. The order of conditions is important because each WSDL file is called from the top of the list down. Example: If the attempt to call the first URI times out, an attempt is made to call the second "backup" URI in the list.

Call Web Services		
Option	Description	
Parse WSDL	<p>Click on a URI in the list so that it is highlighted, and click this button to retrieve routine names, and input and output fields for the WSDL file in question.</p> <p>The available selections are added to:</p> <ul style="list-style-type: none"> • Routine Name • Inputs: Name dropdown list • Outputs: Name dropdown list <p>Note: The selections available in the Inputs: Name and Outputs: Name lists depend on the routine name chosen. Therefore, if you parse a WSDL file, it is recommended that you make your routine name, and input/output name selections in that order.</p>	
Routine Name	<p>The name of the routine, or operation, you wish to execute. You can type in the name, select a variable from the dropdown list or create a new variable by selecting '<NEW VARIABLE>' from the list. If you have clicked <i>Parse WSDL</i> for the WSDL file in question, the available routine names for the file are listed just under the '<NEW VARIABLE>' selection once you have made your port name selection above.</p>	
Inputs	Name	Type in a name for the input value. You can also select a variable from the dropdown list or create a new variable by selecting '<NEW VARIABLE>' from the list. If you clicked <i>Parse WSDL</i> for the WSDL file in question, the available input names for the routine are listed just under the '<NEW VARIABLE>' selection once you have made your routine name selection above.
	Value	Type in the input value. You can also select a variable from the dropdown list or create a new variable by selecting '<NEW VARIABLE>' from the list.

Call Web Services		
Option	Description	
	Add/Remove	Once you have entered a name and assigned it a value, click <i>Add</i> to add it to the 'Inputs' table. To remove a name from the table, highlight the desired row, and click <i>Remove</i> .
Outputs	Name	Type in a name for the output value. You can also select a variable from the dropdown list or create a new variable by selecting '<NEW VARIABLE>' from the list. If you clicked <i>Parse WSDL</i> for the WSDL file in question, the available output names for the routine are listed just under the '<NEW VARIABLE>' selection once you have made your routine name selection above.
	Variable	Select a variable from the dropdown list or create a new variable by selecting '<NEW VARIABLE>' from the list. The output value from the Web service call is assigned to the variable.
	Add/Remove	Once you have entered a name and assigned it a variable, click <i>Add</i> to add it to the 'Outputs' table. To remove a name from the table, highlight the desired row, and click <i>Remove</i> .
Timeout	The number of milliseconds that pass before the action's attempt to call the URI times out and moves on to the next URI in the list. The default is 5000 milliseconds.	
Go To	A dropdown list of all the other actions that have been placed on the page. Select the action that is next in the workflow sequence.	

Call Web Services	
Option	Description
On Failure Go To	A dropdown list of all the other actions that have been placed on the page. Select the action that is next in the workflow sequence should an error occur with this action (for example, if a connection to the Web service cannot be established).
Link Name	Optional fields that are allowing you to label the links that appear between this action and the actions selected in the 'Go To' dropdown lists.
Hide Incoming Links	An optional checkbox that allows you to hide the incoming links for this action. For more information, refer to Hiding Incoming Links on page 38.
Log Action	An optional checkbox that allows you to log information about this action. For more information, refer to Logging Activity for an Action on page 44.

Create Auto Dial Request

Create Auto Dial Request can be used to create a contact that can be queued (using the Queue Object action) for the first available user. Create Audio Dial Request allows you to specify a workflow DN. When a user receives a contact that originated from the Create Auto Dial Request, iceBar automatically dials the workflow DN specified in Create Auto Dial Request.

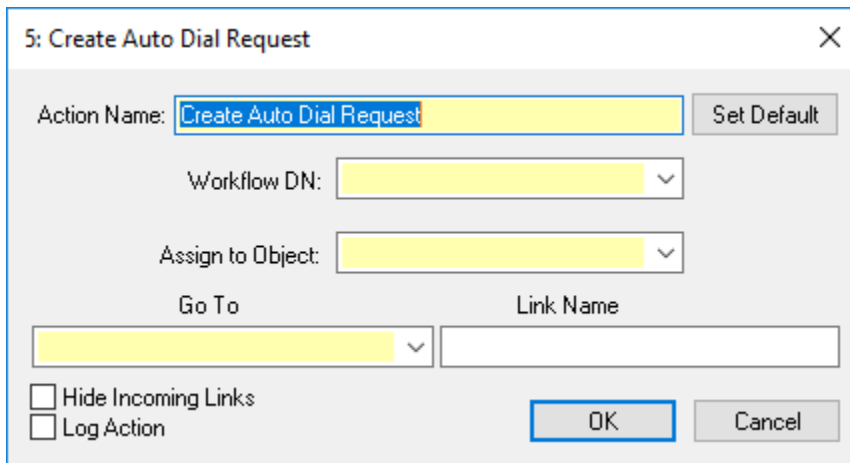

5: Create Auto Dial Request

Action Name: Set Default

Workflow DN:

Assign to Object:

Go To Link Name

Hide Incoming Links

Log Action

OK Cancel

Consider the following two ways that Create Auto Dial Request can be used:

Queued Voice Mail

A queued caller is given the option to leave a voicemail message.

1. The caller records the message and hangs up.
2. A new contact is created using the Create Auto Dial Request.
3. The caller's message is set as User Data for the object (using Set User Data), and the contact is queued.
4. When a user receives this contact, the caller's recording is retrieved (using Get User Data) and played back to the user.

Callback Queuing

A queued caller is given the option to enter his or her phone number and receive a call back from a user at a later time.

1. The caller enters the number and hangs up.
2. A new contact is created using the Create Auto Dial Request.

3. The caller's number is set as User Data for the object, and the contact is queued.
4. When a user receives this contact, the caller's number is retrieved and automatically dialed.

The table below describes the fields and buttons found on the properties dialog box for the Create Auto Dial Request:

Create Auto Dial Request	
Option	Description
Action Name	By default, this field shows the 'Create Auto Dial Request.' You can change this by clearing the field and typing a more descriptive name.
Set Default	A button used to generate a new action name based on the properties selected for the action. For this action, the default name is determined by the workflow DN. The action name is updated when <i>Set Default</i> is clicked (e.g., 'Create AutoDial Request – DN Workflow; 9997').
Workflow DN	A dropdown list of data variables, system variables, and DNs already created with the Assign DN action. This is the number the receiving user automatically dials.
Assign to Object	A dropdown list of object variables you have already created. You can create a new variable by typing the name of the variable directly into the field or by selecting '<NEW VARIABLE>' from the list.
Go To	A dropdown list of all other actions that have been placed on the workflow page. The contact is directed to the selected action.
Link Name	An optional field that allows you to label the link that appears between this action and the action selected from the 'Go To' dropdown list.
Hide Incoming Links	An optional checkbox that allows you to hide the incoming links for this action. For more information, refer to Hiding Incoming Links on page 38.

Create Auto Dial Request	
Option	Description
Log Action	An optional checkbox that allows you to log information about this action. For more information, refer to Logging Activity for an Action on page 44.

Get Object User Data

Get Object User Data is used to retrieve data that has been set for a contact using Set Object User Data.

Consider the following scenario where Get Object User Data can be used:

A queued caller is given the option to leave a voicemail message. The caller records the message and hangs up. A new contact is created (using the Create Auto Dial Request), the caller's message is set as User Data for the object (using the Set User Data action), and the contact is queued. When a user receives this contact, the caller's recording is retrieved using Get Object User Data and played back to the user.

The table below describes the fields and buttons found on the properties dialog box for Get Object User Data:

Get Object User Data	
Option	Description
Action Name	By default, this field shows 'Get Object User Data.' You can change this by clearing the field and typing a more descriptive name.

Get Object User Data	
Option	Description
Set Default	<p>A button used to generate a new action name based on the properties selected for the action.</p> <p>For this action, the default name is determined by the object and the data variable. The action name is updated when <i>Set Default</i> is clicked (e.g., '@RecordedMessage = @call Data' when <i>Set Default</i> is clicked).</p>
Object	A dropdown list of object variables you have already created. You can create a new variable by selecting '<NEW VARIABLE>' from the list.
Store User Data in Variable	A dropdown list of existing data variables. You can create a new variable by typing the name of the variable directly into the field or by selecting '<NEW VARIABLE>' from the list.
Go To	A dropdown list of all other actions that have been placed on the workflow page. The contact is directed to the selected action.
Link Name	An optional field that allows you to label the link that appears between this action and the action selected from the 'Go To' dropdown list.
Hide Incoming Links	An optional checkbox that allows you to hide the incoming links for this action. For more information, refer to Hiding Incoming Links on page 3838.
Log Action	An optional checkbox that allows you to log information about this action. For more information, refer to Logging Activity for an Action on page 44.

Get Telephony Parameter

Get Telephony Parameter is used to read ice telephony parameters that have already been modified using the Set Telephony Parameter action. For more information on Set Telephony Parameter, refer to page 342.

The table below describes the fields and buttons found on the properties dialog box for Get Telephony Parameter:

Get Telephony Parameter	
Option	Description
Action Name	By default, this field shows 'Get Telephony Parameter.' You can change this by clearing the field and typing a more descriptive name.
Set Default	A button used to generate a new action name based on the properties selected for the action. For this action, the default name is determined by the parameter type, parameter name, and the variable in which the parameter value is stored. The action name is updated when <i>Set Default</i> is clicked.

Get Telephony Parameter	
Option	Description
Parameter Name	A dropdown list of existing data variables. You can create a new variable by selecting '<NEW VARIABLE>' from the list. The variable must contain the parameter name as its value. You may also type a parameter name in this field. If the parameter is not found, the action fails. For a list of possible parameters, refer to the 'Telephony Parameters' table below.
Store Parameter Value in Variable	A dropdown list of existing data variables. You can create a new variable by typing the name of the variable directly in to the field or by selecting '<NEW VARIABLE>' from the list.
Go To	A dropdown list of all other actions that have been placed on the workflow page. The contact is directed to this action once the telephony parameter is retrieved.
On Error Go To	A dropdown list of all other actions that have been placed on the workflow page. The contact is directed to this action if an invalid parameter name has been specified.
Link Name	Optional fields that allow you to label the links that appear between this action and the actions selected from the 'Go To' dropdown lists.
Hide Incoming Links	An optional checkbox that allows you to hide the incoming links for this action. For more information, refer to Hiding Incoming Links on page 38.
Log Action	An optional checkbox that allows you to log information about this action. For more information, refer to Logging Activity for an Action on page 44.

The table below describes the available Telephony Parameters.

Telephony Parameters	
Parameter	Values
ice.networkxfermode	0, 1, 2, or 3. For more information, refer to Appendix A: Network Transfer Mode.
ice.SecureLogMode	Prevents logging of DTMF keys in reports.
ice.remoteDisconnectDN	Instructs ice to route the caller to the DN specified after the remote party (user or connected trunk) has disconnected. This feature is useful for post-call surveys.
wf.CustomOutboundCaller Number	Specify an outbound ANI number for a contact in workflow that is routed back out on a trunk.
wf.CustomOutboundCaller Name	Specify an outbound ANI name for a contact in workflow that is routed back out on a trunk.

The table below describes the fields and buttons found on the properties dialog box for Execute Building Block Routine:

Execute Building Block Properties	
Option	Description
Action Name	By default, this field shows 'Execute Building Block Routine.' You can change this by clearing the field and typing a more descriptive name.
Set Default	A button used to generate a new action name based on the properties selected for the action. For this action, the default name is determined by the routine name. The action name is updated when <i>Set Default</i> is clicked (e.g., 'Entry Point').
Building Block	A dropdown list of building blocks.
Routine	A dropdown list of routines that have public access and belong to the selected building block. For more information, refer to Routine Access: Public or Private on page 147.
Go To Entry Point	Click to jump to the action in the routine that has been defined as the routine entry point. If you have read only privileges for the routine, you may view the properties for the routine (but not the routine workflow). For more information on access levels for routines, refer to page 138.
Argument	Select an argument from the drop down list. The arguments are defined in the routine. For more information, refer to page 148.
Pass By	This field cannot be modified and shows either 'Value' or 'Reference,' as defined for the argument in the routine. For more information, refer to page 148.
Value	Enter a value for the selected argument. You can type in the value, select a variable from the dropdown list or create a new variable by selecting '<NEW VARIABLE>' from the list.

Execute Building Block Properties	
Option	Description
Set Value	Click to update the value in the argument table. Arguments that require a value to be set are displayed in red text.
Clear All Values	Click to remove all values that you have set for the arguments.
Assign Return Value to Variable	Select a variable that will be used to store the return value from the routine, if applicable. You may select a variable from the dropdown list or create a new variable by selecting '<NEW VARIABLE>' from the list.
Go To	A dropdown list of all other actions that have been placed on the workflow page. The contact is directed to this action when the routine is complete.
On Failure Go To	A dropdown list of all the other actions that have been placed on the page. Select the action that is next in the workflow sequence should an error occur with this action.
Link Name	Optional fields that allow you to label the links that appear between this action and the actions selected from the 'Go To' dropdown lists.
Hide Incoming Links	An optional checkbox that allows you to hide the incoming links for this action. For more information, refer to Hiding Incoming Links on page 38.
Log Action	An optional checkbox that allows you to log information about this action. For more information, refer to Logging Activity for an Action on page 44.

Execute External Action

This action can be used to integrate executable files, command files, or Dynamic-Link Library (DLL) functions into the workflow. For example, you might execute function calls from a DLL to query a database or retrieve information from an initialization file. You might use an executable or command file to copy scripts or to FTP (File Transfer Protocol) a file.

Dynamic Link Library

Radio buttons on the properties dialog box for Execute External Action allow you to select DLL or EXE/CMD. When DLL is selected, Execute External Action can integrate a DLL function into the workflow.

21: Execute External Action [X]

Action Name:

Dynamic Link Library Executable (EXE) or Command File (CMD)

DLL Name:

DLL Function: Run in TIM
 Run in Workflow

Blocking: Wait for program to complete Do not wait

Window: Minimized Normal Maximized

Return Type:

Assign Return Value to Variable:

Argument	Type	Value
<input type="text"/>	<input type="text"/>	<input type="text"/>

Argument	Type	Value

Go To: Link Name:

On Failure Go To: Link Name:

Hide Incoming Links
 Log Action

Note: Running DLLs at the telephony layer is not supported.

Consider the following examples of Execute External Action when DLL is selected:

- Execute External Action might be used to query a database. For example, you may be able to retrieve a caller's account number from a database based on their ANI (the number they have called from).
- Execute External Action might be used to access an initialization file. For example, the initialization file might indicate the queue or user to which a caller should be directed, based on the caller's input.

The table below describes the fields and buttons found on the properties dialog box for Execute External Action when DLL is selected:

Execute External Dynamic Link Library Properties	
Option	Description
Action Name	By default, this field shows 'Execute External Action.' You can change this by clearing the field and typing a more descriptive name.
Set Default	A button used to generate a new action name based on the properties selected for the action. For this action, the default name is determined by the DLL name and DLL function. The action name is updated when <i>Set Default</i> is clicked (e.g., '@DLL - @DLLFunction').
DLL Name	A dropdown list of existing data variables. You can create a new variable by selecting '<NEW VARIABLE>' from the list. The variable must have the directory path as its value. You may also type a directory path in this field. If no directory is specified, the action looks for the DLL in D:\ice\bin, D:\ice\workflowBin, or system path on the ice server. If no DLL is found the action fails.
DLL Function	A dropdown list of existing data variables. You can create a new variable by selecting '<NEW VARIABLE>' from the list. If selected, the variable must have the function name as its value. You may type the name of the DLL function to be called.
Run in TIM	N/A
Run in Workflow	Execute built in workflow functions.
Return Type	A dropdown list with the following return types: INT64, VOID. The return type selected must match the type of value returned by the DLL.
Assign Return Value to Variable	A dropdown list of existing data variables. You can create a new variable by typing the name of the variable directly in to the field or by selecting '<NEW VARIABLE>' from the list. The return value is stored in the specified variable. This field is not required if VOID is selected as the return type.
Argument	A dropdown list with numbers 1 through 255. If required add arguments to the table.

Execute External Dynamic Link Library Properties	
Option	Description
Type	A dropdown list with the following argument types: BOOL*, DOUBLE, DOUBLE*, FLOAT*, LONG*, SHORT*, STRING (CHAR*), INT64, INT64*.
Value	A dropdown list of existing data variables, as well as system variables. You can create a new variable by selecting '<NEW VARIABLE>' from the list. You may also type a static value in this field. This value is passed to the function.
Go To	A dropdown list of all other actions that have been placed on the workflow page. The contact is directed to this action after the value is returned.
On Error Go To	A dropdown list of all other actions that have been placed on the workflow page. The contact is directed to this action if DLL or function is not found.
Link Name	Optional fields that allow you to label the links that appear between this action and the actions selected from the 'Go To' dropdown lists.
Hide Incoming Links	An optional checkbox that allows you to hide the incoming links for this action. For more information, refer to Hiding Incoming Links on page 38.
Log Action	An optional checkbox that allows you to log information about this action. For more information, refer to Logging Activity for an Action on page 44.

Note:

- The number of arguments, their order, and their types must be correct for the function to work properly.
- DLL functions always wait for return values before the contact can continue in the workflow. However, with executable programs or command files, you can select the appropriate 'Blocking' type. This determines if the contact waits for the executable or command file to complete, or continues through the workflow.

- If a DLL uses the Windows® operating system Regional Settings, note that these settings are only loaded when the DLL is loaded. If you change the Regional Settings, you will need to restart ice for these changes to take effect.
- DLL functions can be written in any language, but must conform to the standard DLL argument-passing convention and must be 32-bit. Ensure that DLL functions are exported, so that they are accessible by the workflow.
- If using C++, disable "name mangling" on your DLL functions. This can be done using the "C" directive in an "extern" declaration.
- Sample code –

```
// Sample Header File for Custom DLL – customdll.h
```

```
//
```

```
// The following ifdef block is the standard way of creating macros which //make  
exporting from a DLL simpler. All files within this DLL are compiled //with the  
CUSTOMDLL_EXPORTS symbol defined on the command line. //this symbol should  
not be defined on any project that uses this DLL. This //way any other project whose
```

source files include this file see //CUSTOMDLL_API functions as being imported from a DLL, whereas this //DLL sees symbols defined with this macro as being exported.

```
#ifndef CUSTOMDLL_EXPORTS  
  
#define CUSTOMDLL_API extern "C" __declspec(dllexport)  
  
#else  
  
#define CUSTOMDLL_API extern "C" __declspec(dllimport)  
  
#endif
```

```
CUSTOMDLL_API short SampleFunction(long IParam);
```

```
// Sample Source File for Custom DLL - customdll.cpp
```

```
#include "stdafx.h"
```

```
#include "customdll.h"
```

```
CUSTOMDLL_API short SampleFunction(long IParam)
```

```
{
```

```
    .. CODE ..
```

```
}
```

Executable or Command File

21: Execute External Action

Action Name:

Dynamic Link Library Executable (EXE) or Command File (CMD)

Executable:

Command Line: Run in TIM Run in Workflow

Blocking: Wait for program to complete Do not wait

Window: Minimized Normal Maximized

Return Type:

Assign Return Value to Variable:

Argument	Type	Value
<input type="text"/>	<input type="text"/>	<input type="text"/>

Argument	Type	Value

Go To: Link Name:

On Failure Go To: Link Name:

Hide Incoming Links Log Action

Radio buttons on the properties dialog box for Execute External Action allow you to select 'DLL' or 'Executable (EXE) or Command File (CMD).' When EXE/CMD is selected, Execute External Action can integrate an executable program or command file into the workflow. Consider the following examples of Execute External Action when EXE/CMD is selected:

- Execute External Action might be used to FTP a file. For example, you may want to post some information on a website on a daily basis.
- Execute External Action might be used to copy scripts. For example, scripts can be copied to a shared directory.

The table below describes the fields and buttons found on the properties dialog box for Execute External Action when EXE/CMD is selected:

Execute External Executable (EXE) or Command File (CMD) Properties	
Option	Description
Action Name	By default, this field shows 'Execute External Action.' You can change this by clearing the field and typing a more descriptive name.
Set Default	A button used to generate a new action name based on the properties selected for the action. For this action, the default name is determined by the executable and command line. The action name is updated when <i>Set Default</i> is clicked (e.g., '@Executable - @CommandLine').
Executable	A dropdown list of existing data variables. You can create a new variable by selecting '<NEW VARIABLE>' from the list. If selected, the variable must have the directory path as its value. You may type a directory path in this field. If no directory is specified, the action looks for the EXE in the D:\ice\bin directory on the ice server. If the EXE is not found, the action then looks to the SYSTEM32 directory on the ice server. If no EXE is found, the action fails.
Command Line	A dropdown list of existing data variables. You can create a new variable by selecting '<NEW VARIABLE>' from the list. If selected, the variable must have the command line as its value. You may also type a static value in this field. This is the command line argument(s) with which the executable program is invoked. It may contain several arguments separated by spaces.
Blocking	Radio buttons allow you to select from the following options: Select 'Wait for the program to complete,' indicating the contact does not continue through workflow until the executable is complete, or 'Do not wait,' indicating the contact continues to the action selected from the 'Go To' dropdown list without waiting. 'Do not wait' is the default setting.
Window	Radio buttons allow you to select from the following options: Minimized, Normal, or Maximized. The default setting is Normal.

Execute External Executable (EXE) or Command File (CMD) Properties	
Option	Description
Go To	A dropdown list of all other actions that have been placed on the workflow page. If blocking has been set to 'Do no wait' the contact is directed to this action immediately.
On Error Go To	A dropdown list of all other actions that have been placed on the workflow page. The contact is directed to this action if the executable is not found.
Link Name	Optional fields that allow you to label the links that appear between this action and the actions selected from the 'Go To' dropdown lists.
Hide Incoming Links	An optional checkbox that allows you to hide the incoming links for this action. For more information, refer to Hiding Incoming Links on page 38.
Log Action	An optional checkbox that allows you to log information about this action. For more information, refer to Logging Activity for an Action on page 44.

Exit Building Block Routine

This action can only be used within a building block to return to the point in the workflow where the Execute Building Block Routine action was used. For more information on building blocks, refer to Chapter 5: Building Blocks.

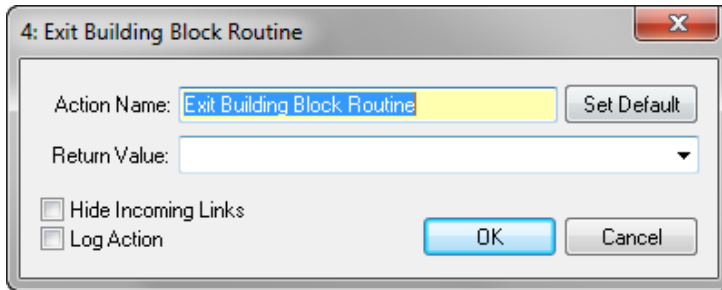

The table below describes the fields and buttons found on the properties dialog box for Execute Building Block Routine:

Execute Building Block Properties	
Option	Description
Action Name	By default, this field shows 'Execute Building Block Routine.' You can change this by clearing the field and typing a more descriptive name.
Set Default	A button used to generate a new action name based on the properties selected for the action. For this action, the default name is determined by the routine name. The action name is updated when <i>Set Default</i> is clicked (e.g., 'Entry Point').
Return Value	Enter the return value. You can type in the value, select a variable from the dropdown list, or create a new variable by selecting '<NEW VARIABLE>' from the list.
Hide Incoming Links	An optional checkbox that allows you to hide the incoming links for this action. For more information, refer to Hiding Incoming Links on page 38.
Log Action	An optional checkbox that allows you to log information about this action. For more information, refer to Logging Activity for an Action on page 44.

Make Call

9: Make Call

Action Name:

Outbound DN: Object:

Bypass Conference

SIP Response Code: No Answer Timeout: ms

Call Progress Timeout

Call Progress Timeout: ms

Connect on Call Progress Timeout

Configuration

Tone Scheme:

Speech Language:

Speech Grammar:

Record Option

Use the following File Name:

Play Audio

Music On Hold

Ringback

Play Audio File

Loop

Play Ringback

Play Music On Hold

No Call Progress Analysis

Completion Conditions

Remote Line Answered

Ringing Begins

Special Information Tone (SIT)

Fax/Modem Detected

Voice Begin Detected

Medium Voice Detected

Min: ms

Max: ms

Long Voice Detected

Min: ms

Max: ms

Extended Voice Detected

Silence Detected After Voice

Medium: ms

Long: ms

Extended: ms

Speech Recognized

Rule 1:

Rule 2:

Rule 3:

Rule 4:

Voice Qualification Time: ms

Go To

On Success: Link Name:

On Failure: Link Name:

Hide Incoming Links

Log Action

Make Call is used to initiate outbound calls from ice. Make Call can function similarly to Route Object. However, unlike Route Object, Make Call does not have to be triggered by an inbound call. Make Call supports call progress analysis when dialing external DNs, meaning that it can determine if the line is ringing, if the line has been answered, if the called party has spoken, etc.

When using the Make Call action to route calls, the success or failure links will be followed in all cases except when the destination is a workflow DN or when the destination is a user who forwards the call to a workflow DN.

Note: Each call is limited to one Make Call workflow action. Back-to-back Make Call actions are disallowed.

Consider the following ways that Make Call can be used:

- Predictive Dialer Applications – for example, make a call to a client whose number has been placed on a call-back list.
- Transfers - perform a transfer with call progress detection. (**Note:** A call can be transferred with the Route Object action, but that action does not allow for call progress detection). Make Call allows the workflow to monitor what happens to a call when it is transferred.
- Monitoring Active Calls in ice - For example, use the Make Call action to detect voice activity for a call in the workflow.

The table below describes the fields and buttons found on the properties dialog box for Make Call:

Make Call	
Option	Description
Action Name	By default, this field shows 'Make Call.' You may type a new name in this field.
Set Default	A button used to generate a new action name based on the properties selected for the action. For this action, the default name is determined by the outbound DN. The action name is updated when the <i>Set Default</i> button is clicked (e.g., 'DN @OutboundDN').
Outbound DN	A drop-down list of data variables, DNs already created with the Assign DN action, and user IDs. You may also enter a number in this field (i.e., 94169671111 to dial an external number). You do not need to include an access code for the trunk group you are using the action to originate a new call. You can create a new variable by selecting '<NEW VARIABLE>' from the list. For monitoring active calls on ice, leave this field blank.
Object	A drop-down list of object variables you have already created. You can create a new variable by

Make Call	
Option	Description
	typing the name of the variable directly in to the field or by selecting '<NEW VARIABLE>' from the list.
No Answer Timeout	<p>The number of seconds that ice waits for the far end (i.e., the called party) to answer, in milliseconds (e.g., 2000ms equals 2 seconds). When the timeout is reached, the contact follows the 'On Failure' link. You can select a variable for the No Answer timeout, or create a new variable by selecting '<NEW VARIABLE>' from the list.</p> <p>Note: The No Answer timeout behaves differently depending on the protocol used on the trunk:</p> <p>For ISDN and SIP calls, the timeout refers to the maximum amount of time that can elapse between the Call Proceeding state and the network's Connected state. The time taken for call progress detection is not included in the calculation.</p> <p>For other protocols (e.g., Wink Start, Loop Start) the timeout refers to the maximum amount of time that can elapse between the Call Proceeding state and the Connected state on ice. The time taken for call progress detection is included in the calculation.</p>
Call Progress Timeout	<p>The number of seconds that ice waits for activity at the far end (i.e., the called party), in milliseconds (e.g., 2000ms equals 2 seconds). If no activity is detected, the contact follows the 'On Failure' link.</p> <p>Note: The Call Progress timeout behaves differently depending on the protocol used on the trunk:</p> <p>For ISDN and SIP calls, the timeout refers to the maximum amount of time that call progress detection can take on network connected calls.</p> <p>For other protocols (e.g., Wink Start, Loop Start) the timeout refers to the maximum amount of time that can elapse with no network stimulus. If network</p>

Make Call	
Option	Description
	stimulus is detected, the Call Progress timeout is disabled, and the No Answer timeout will come into effect.
Connect on Call Progress Timeout	If this option is disabled, and the Call Progress timer is reached, the failure link is followed. If this option is enabled, Make Call will return success if call progress timeout is reached.
Configuration	<p>This section contains options for recognizing tones and grammars.</p> <p><u>Tone Scheme</u>: Dropdown list of countries with supported tones. Tone Scheme will become enabled as soon as No Call Progress is disabled and Begin Ringing, Special Information Tone (SIT), or Modem / Fax detected are selected.</p> <p>By default, Speech Language and Speech Grammar are disabled. Once No Call Progress is disabled and Speech Recognized is enabled, you can choose the Speech Language and Speech Grammar for the Rules you selected.</p> <p><u>Speech Language</u>: Dropdown list of languages that are supported by the Microsoft speech engine.</p> <p><u>Speech Grammar</u>: Dropdown list of grammar files to be used for speech recognition.</p>
Record Option	The recording file captures the period of time that the <i>Make Call</i> action completes call progress analysis using speech detection or SIP tone analysis. This can be played back later if there is an issue with the call progress analysis.
Completion Conditions	You can choose to have No Call Progress Analysis on the call, or you can choose one or more of the completion conditions for the call, as described on page 328. If you have selected multiple completion conditions, then you will have to look at the value

Make Call	
Option	Description
	of the system variable \$System:ResultCode to determine which condition was met first. Refer to the 'Completion Conditions' table below for more information on result codes.
On Success	A drop-down list of all other actions that have been placed on the workflow page. Contacts are directed to the action you select from this list when the Completion Conditions are met. If in transfer mode, all non-telephony actions are completed before the calls are connected.
On Failure	A drop-down list of all other actions that have been placed on the workflow page. Contacts are directed to the action you select from this list if the DN is not valid or cannot be dialed; the 'No Answer Timeout' is met, or the 'Call Progress Timeout' is met (and 'Connect on Call Progress Timeout' is disabled).
Link Name	Optional fields that allow you to label the links that appear between this action and the actions selected from the 'Go To' drop-down lists.
Hide Incoming Links	An optional checkbox that allows you to hide the incoming links for this action. Refer to page 38 for more information.
Log Action	An optional checkbox that allows you to log information about this action. Refer to page 153 for more information.

The table below describes completion conditions.

Completion Conditions	
Completion Condition	Make Call Recognizes...
No Call Progress Analysis	When this option is selected, Make Call only performs remote line answered detection with no answer timeout. Call progress timeout will not be used. The success link is followed immediately after the remote line is answered.
Remote Line Answered	The call has been answered at the far end (e.g., the line has been "picked up").
Ringing Begins	Ringing at the far end.
Ringing Ends	Ringing has ceased at the far end.
Special Information Tone (SIT)	A Special Information Tone (SIT) is played at the far end (e.g., the tone that plays before a message indicating the number is no longer in service). ice does not distinguish between different Special Information Tones.
Fax/Modem Detected	The call has been answered by fax or modem at the far end.
Voice Begin Detected	Voice energy is detected. For example, voice energy is detected when a person speaks at the far end. The speech recognition engine is utilized to detect the presence of voice energy.
Medium / Long / Extended Voice Detected	Voice energy with user-specified voice energy, with configurable min and max durations. Optionally, speech recognition rules can be defined and applied to recognize certain words or sentence when voice energy is detected. This may be used for additional verification that a certain SIT message has been received. If the specified words or sentence is detected, call progress returns immediately

Completion Conditions	
Completion Condition	Make Call Recognizes...
Silence Detected After Voice	User-specified duration of silence after detecting voice energy. This setting can be used to detect a person who has said 'Hello' and is waiting for a response.
Speech Recognized	What is spoken based on speech recognition rules. Once this is selected, speech language and the appropriate speech grammar file must be selected.
Voice Qualification Time	The minimum amount of time (in seconds) that voice energy must be present in order to indicate voice is received and return Voice Begin Detected as the completion condition. Defaults to 120 milliseconds.

The table below lists the common values that are returned when Make Call follows the 'On Success Go To' path.

Success Result Codes	
Value	Result
32	Remote line answered.
33	Fax/Modem detected.
35	No call progress.
36	Ringing begins.
39	Special Information Tone detected.
40	Call progress timeout.
41	Voice begins to be detected.
43	Extended voice detected.
44	Long voice detected.

Success Result Codes	
Value	Result
45	Medium voice detected.
50	Speech recognized with Rule 1
51	Speech recognized with Rule 2
52	Speech recognized with Rule 3
53	Speech recognized with Rule 4

The table below lists the common values that are returned when Make Call follows the 'On Failure Go To' path.

Failure Result Codes	
Value	Result
17	User busy.
18	No user is responding or SIT detected.
19	No answer from user (No Answer Timer expired).
21	Reorder tone.
47	Resource unavailable.
86	Call cleared or far end disconnected before call progress completed.
88	Incompatible destination (returned if CED is detected).
102	Recovery on timer expired (Call Progress Timeout expired).
111	Protocol error (e.g., call establish failed).

Obtain Lock

This action is used to lock a section workflow so that only one port can have access to it at a time. It can be used to lock a multi-port variable so that it may be updated before it is accessible to other ports.

Note: The lock will remain in place until the Release Lock action is used, a telephony action is encountered (e.g., Play Audio File or Get Input), or until the caller disconnects.

The table below describes the fields and buttons found on the properties dialog box for Obtain Lock:

Obtain Lock Properties	
Option	Description
Action Name	By default, this field shows 'Obtain Lock.' You can change this by clearing the field and typing a more descriptive name.
Set Default	A button used to set the default action name. For this action, the default name is 'Obtain Lock.'
Lock Name	The unique name for the lock. You can type in the name, select a variable from the dropdown list or create a new variable by selecting '<NEW VARIABLE>' from the list.
Go To	A dropdown list of all other actions that have been placed on the workflow page. The contact is directed to the selected action when the lock is established.

Obtain Lock Properties	
Option	Description
On Failure Go To	A dropdown list of all other actions that have been placed on the workflow page. The contact is directed to the selected action if the lock cannot be established.
Hide Incoming Links	An optional checkbox that allows you to hide the incoming links for this action. For more information, refer to Hiding Incoming Links on page 38.
Log Action	An optional checkbox that allows you to log information about this action. For more information, refer to Logging Activity for an Action on page 44.

Output Debug String

Output Debug String allows you to write a debug string to iceDiagnostics Manager. For example, you can use this action to record error messages that occur during workflow or to record the results of database queries.

The table below describes the fields on the Output Debug String properties dialog box:

Output Debug String	
Option	Description
Action Name	By default, this field shows 'Output Debug String.' You can change this by clearing the field and typing a more descriptive name.
Set Default	A button used to set the default action name. For this action, the default name is 'Output Debug String.'

Output Debug String	
Option	Description
Application ID	A means of identifying the source of the string (e.g., the port on which the relevant call was handled) so that it is more easily located in iceDiagnostics Manager. You can select a variable from the dropdown list, or create a new variable by selecting '<NEW VARIABLE>' from the list. You may also type a static value in this field.
Severity	Sets the severity of the error or message. Select 'No Error,' 'Moderate,' 'Serious,' or 'Severe' from the dropdown list. The default is 'No Error.'
Output String	The string you wish to send to iceDiagnostics Manager. This can be text, variables, or a combination thereof.
Variable/Insert	To insert a variable into the 'Output String' field, select it from the dropdown list or select '<NEW VARIABLE>' to create a new variable. Click <i>Insert</i> .
Go To	A dropdown list of all the other actions that have been placed on the page. Select the action that is next in the workflow sequence.
Link Name	Optional fields that allow you to label the links that appear between this action and the actions selected in the 'Go To' dropdown lists.
Hide Incoming Links	An optional checkbox that allows you to hide the incoming links for this action. For more information, refer to Hiding Incoming Links on page 3838.
Log Action	An optional checkbox that allows you to log information about this action. For more information, refer to Logging Activity for an Action on page 44.

Release Lock

This action releases the lock that is established with the Obtain Lock action.

The table below describes the fields and buttons found on the properties dialog box for Release Lock:

Release Lock Properties	
Option	Description
Action Name	By default, this field shows 'Release Lock.' You can change this by clearing the field and typing a more descriptive name.
Set Default	A button used to set the default action name. For this action, the default name is 'Release Lock.'
Lock Name	The unique name for the lock. You can type in the name, select a variable from the dropdown list or create a new variable by selecting '<NEW VARIABLE>' from the list.
Go To	A dropdown list of all other actions that have been placed on the workflow page. The contact is directed to the selected action.
Hide Incoming Links	An optional checkbox that allows you to hide the incoming links for this action. For more information, refer to Hiding Incoming Links on page 38.
Log Action	An optional checkbox that allows you to log information about this action. For more information, refer to Logging Activity for an Action on page 44.

Set User Whisper

This action can be used to announce the call's purpose to a user and is particularly helpful in contact centers where the user may not always use iceBar to determine the origin of the call.

1: Set User Whisper

Action Name:

Object:

Whisper using: Audio File TTS
 Use Base Subdirectory

Audio File:

Language:

Set Text using Variable

Variable:

Text

Go To Link Name

Hide Incoming Links
 Log Action

Set User Whisper can be used to play an audio file to a user, or speak text to a user:

- Associate an audio file with a contact. Just before the contact is presented to a user, the audio file is played to the user. After the audio file has played, the user is connected to the contact.
- Associate text with a contact. Just before the contact is presented to a user, the text is “read back” to the user. After the text has played, the user is connected to the contact. Using text-to-speech, dynamic data, such as caller name or account number, can be whispered to the user. For more information on text-to-speech, refer to page 402.

Note:

- While the audio file or text is played, the caller's time is calculated as 'Alerting.'
- ice must be configured with "text-to-speech" capabilities in order for the text to be played to a user. If "text-to-speech" is not configured on the system, the user does not hear the whisper before he or she is connected to the contact.
- If the time a contact has been queued is whispered to a user, the workflow must reset the whisper text to reflect the new time queued (e.g., reset the whisper text every ten seconds to update the amount of time that the contact has been queued).
- If a contact passes through multiple Set User Whisper actions, the audio file specified in the last Set User Whisper action is used when the contact is presented to the user.

The table below describes the fields and buttons found on the properties dialog box for Set User Whisper:

Set User Whisper	
Option	Description
Action Name	By default, this field shows 'Set User Whisper.' You may type a new name in this field.
Set Default	A button used to generate a new action name based on the properties selected for the action. For this action, the default name is determined by the audio file. The action name is updated when the Set Default button is clicked (e.g., 'User Whisper – 10000.vox').
Object	A drop-down list of object variables you have already created. You can create a new variable by selecting '<NEW VARIABLE>' from the list.
Whisper using	Radio buttons allow you to select 'Audio File' or 'TTS.'
Use Base Subdirectory	If you enable this checkbox, the message played for the audio file specified below will be from the base subdirectory selected in the most recent Set Audio File Base Subdirectory action in the workflow. For example, if the base subdirectory is set to 'French' in workflow, the French version of the audio file is played.

Set User Whisper	
Option	Description
Audio File	Select an audio message you have already created or a data variable you have created with an audio message as the value of the variable. You can also create a new variable or audio message by selecting '<NEW VARIABLE>' or '<NEW AUDIO MESSAGE>' from the list. This field is only available if you have selected to use an audio file for the whisper.
TTS Group ID	Group IDs, which start at 0, is created for each voice used by your contact center. For example, a contact center that uses two voices for the Speak action can have two groups IDs: Group ID 0 represents Tom (the English Male voice), and group ID 1 represents Felix (the French Male voice). The group IDs that you can use depend on the configuration of your ice server and your Speechify license. This field is only available if you have selected to use TTS for the whisper.
Set Text using Variable	Select this checkbox if you wish to select a variable (from the 'Variable' field) that contains the text to be spoken to the user.
Variable	A drop-down list of system variables, as well as data variables you have already created. You can also create a new variable by selecting '<NEW VARIABLE>' from the drop-down list box. The selected variable should contain the text to be spoken to the user.
Text	If you are not using a variable to set the text, enter the desired text in this field.
Go To	A drop-down list of all other actions that have been placed on the workflow page. Contacts are directed to the action you select from this list.
Link Name	An optional field allowing you to label the link that appears between this action and the action selected from the 'Go To' drop-down list.

Set User Whisper	
Option	Description
Hide Incoming Links	An optional checkbox that allows you to hide the incoming links for this action. Refer to page 38 for more information.
Log Action	An optional checkbox that allows you to log information about this action. Refer to page 153 for more information.

Set Object User Data

Set Object User Data is used to associate a piece of information with a caller. This information can then be passed from iceBar to any Customer Relationship Management (CRM) application. For example, the workflow might be customized to retrieve a customer's account number from a database that already exists in your contact center. The account number can then be associated with the contact using this action.

The table below describes the fields and buttons found on the properties dialog box for Set Object User Data:

Set Object User Data	
Option	Description
Action Name	By default, this field shows 'Set Object User Data.' You can change this by clearing the field and typing a more descriptive name.
Set Default	A button used to generate a new action name based on the properties selected for the action. For this action, the default name is determined by the object and the user data. The action name is updated when <i>Set Default</i> is clicked (e.g., '@call – @TicketNumber.wma').
Object	A dropdown list of object variables you have already created. Select the object variable that represents the contact. You can create a new variable by selecting '<NEW VARIABLE>' from the list.

Set Object User Data	
Option	Description
User Data	A dropdown list of existing data variables. You can create a new variable by selecting '<NEW VARIABLE>' from the list. You may also type a static value in this field. The user data is limited to 256 characters.
Go To	A dropdown list of all other actions that have been placed on the workflow page. Contacts are directed to the action you select from this list after the data is set.
Link Name	An optional field allowing you to label the link that appears between this action and the action selected from the 'Go To' dropdown list.
Hide Incoming Links	An optional checkbox that allows you to hide the incoming links for this action. For more information, refer to Hiding Incoming Links on page 38.
Log Action	An optional checkbox that allows you to log information about this action. For more information, refer to Logging Activity for an Action on page 44.

Note: Additional configuration is required on iceBar to pass this data to a CRM package.

Set Telephony Parameter

The screenshot shows a dialog box titled "14: Set Telephony Parameter". It features the following elements:

- Action Name:** A text field containing "Set Telephony Parameter" and a "Set Default" button.
- Parameter Name:** A dropdown menu.
- Parameter Value:** A dropdown menu.
- Go To:** A dropdown menu.
- Link Name:** A text input field.
- On Failure Go To:** A dropdown menu.
- Link Name:** A text input field.
- Options:** Two checkboxes: "Hide Incoming Links" and "Log Action".
- Buttons:** "OK" and "Cancel" buttons.

Set Telephony Parameter is used to modify ice telephony parameters:

This action can be used to enable or disable SIP REFER transfers on ice. For more information, refer to Appendix A: Network Transfer Mode.

The table below describes the fields and buttons found on the properties dialog box for Set Telephony Parameter:

Set Telephony Parameter	
Option	Description
Action Name	By default, this field shows the 'Set Telephony Parameter.' You can change this by clearing the field and typing a more descriptive name.
Set Default	A button used to generate a new action name based on the properties selected for the action. For this action, the default name is determined by the parameter type, parameter name, and the variable in which the parameter value is stored. The action name is updated when <i>Set Default</i> is clicked.

Set Telephony Parameter	
Option	Description
Parameter Name	A dropdown list of existing data variables. You can create a new variable by selecting '<NEW VARIABLE>' from the list. The variable must contain the parameter name as its value. You may type a parameter name in this field. If the parameter is not found, the action fails. For a list of possible parameters, refer to the 'Telephony Parameters' table below.
Parameter Value	A dropdown list of existing data variables, as well as system variables. You can create a new variable by selecting '<NEW VARIABLE>' from the list. You may also type a static value in this field.
Go To	A dropdown list of all other actions that have been placed on the workflow page. The contact is directed to this action once the telephony parameter is set.
On Error Go To	A dropdown list of all other actions that have been placed on the workflow page. The contact is directed to this action if an invalid parameter name has been specified.
Link Name	Optional fields that allow you to label the links that appear between this action and the actions selected from the 'Go To' dropdown lists.
Hide Incoming Links	An optional checkbox that allows you to hide the incoming links for this action. For more information, refer to Hiding Incoming Links on page 38.
Log Action	An optional checkbox that allows you to log information about this action. For more information, refer to Logging Activity for an Action on page 44.

The table below describes the available Telephony Parameters.

Telephony Parameters	
Parameter	Values
ice.networkxfermode	0, 1, 2, or 3. For more information, refer to Appendix A: Network Transfer Mode.

Telephony Parameters	
Parameter	Values
ice.SecureLogMode	Prevents logging of DTMF keys in reports.
wf.RemoteDisconnectDN	Specify a remote DN for a contact in the workflow. When the contact is routed to a remote user, the user will be called using the specified DN for the contact.
wf.CustomOutbound CallerNumber	Specify an outbound ANI number for a contact in workflow that is routed back out on a trunk.
wf.CustomOutbound CallerName	Specify an outbound ANI name for a contact in workflow that is routed back out on a trunk.

Recording Control

7: Recording Control

Action Name:

(Audio Only)

Recording Action:

Go To Link Name

On Failure Go To Link Name

Hide Incoming Links

Log Action

Recording Control	
Option	Description
Action Name	By default, this field shows 'Recording Control.' You can change this by clearing the field and typing a more descriptive name.
Set Default	A button used to generate a new action name based on the properties selected for the action. For this action, the default name is determined by the parameter type, parameter name, and the variable in which the parameter value is stored. The action name is updated when <i>Set Default</i> is clicked.

Recording Control	
Option	Description
Recording Action	A list of recording control actions that can be selected, which include (more details below): <ul style="list-style-type: none"> ▪ Pause With Privacy Tones ▪ Pause recording and insert privacy tones ▪ Request Random Recording ▪ Resume ▪ Start Recording Immediately ▪ Start Recording When Call Arrives To User ▪ Stop Recording
Go To	A dropdown list of all other actions that have been placed on the workflow page. The contact is directed to this action once the telephony parameter is set.
On Failure Go To	A dropdown list of all other actions that have been placed on the workflow page. The contact is directed to this action if an invalid parameter name has been specified.
Link Name	Optional fields that allow you to label the links that appear between this action and the actions selected from the 'Go To' dropdown lists.
Hide Incoming Links	An optional checkbox that allows you to hide the incoming links for this action. For more information, refer to Hiding Incoming Links on page 38.
Log Action	An optional checkbox that allows you to log information about this action. For more information, refer to Logging Activity for an Action on page 44.

The table below describes the available recording actions.

Recording Action	
Option	Description
Pause with Privacy Tone	Pause voice recording and replace with privacy tones until the recording is resumed or stopped.

Recording Action	
Option	Description
Request Random Recording	Start recording if the agent's number of unscored random recordings is less than the Max Unscored Recordings Per User setting configured in iceManager; otherwise, assuming there are no other triggers, the contact would not be recorded. Note: The Random Recording has to be enabled in iceManager for it to be active in iceWorkflow,
Resume	Resume recording of call if previously paused.
Start Recording Immediately	Start recording of the call.
Start Recording When Call Arrives to User	Start recording of the next call when it is received by the user.
Stop Recording	Stop recording of the call.

Virtual Workflow

Virtual workflows are used to kick off workflow sessions for outbound applications such as iceCampaign and iceAlert. The WCF configuration tab allows you to specify a list of switch ID and port pairs that will dictate the number of WCF endpoints started by the service. Users can configure the virtual workflow to set up jobs to be run in startup sessions.

Virtual Workflow	
Option	Description
Action Name	By default, this field shows the 'Set Telephony Parameter.' You can change this by clearing the field and typing a more descriptive name.
Set Default	A button used to generate a new action name based on the properties selected for the action. For this action, the default name is determined by the parameter type, parameter name, and the variable in which the parameter value is stored. The action name is updated when <i>Set Default</i> is clicked.

Virtual Workflow	
Option	Description
Group ID	A dropdown list containing the UC groups and Email groups you have configured in your contact center.
Contact Type	A dropdown list containing the contact types that the virtual workflow action can handle. Voice, email, and IM are the available options.
User Data	A dropdown list of existing data variables. You can create a new variable by selecting '<NEW VARIABLE>' from the list. You may also type a static value in this field. The user data is limited to 256 characters. Note: This is an option setting.
Go To	A dropdown list of all other actions that have been placed on the workflow page. The contact is directed to this action once the telephony parameter is set.
On Failure Go To	A dropdown list of all other actions that have been placed on the workflow page. The contact is directed to this action if an invalid parameter name has been specified.
Link Name	Optional fields that allow you to label the links that appear between this action and the actions selected from the 'Go To' dropdown lists.
Hide Incoming Links	An optional checkbox that allows you to hide the incoming links for this action. For more information, refer to Hiding Incoming Links on page 38.
Log Action	An optional checkbox that allows you to log information about this action. For more information, refer to Logging Activity for an Action on page 44.

Virtual workflows are started in two ways: at system startup, or by a call to a WCF service. Both of these are managed by VirtualWorkflowService, which is installed and run on every ice installation.

In order to use virtual workflow, you need to create a UC group for handling virtual workflow actions. You specify the terminus for the UC group as the starting action for the workflow you want to run.

This is all that needs to be done in iceManager Administrator in order to set up virtual workflow. ComputerTalk Technology, Inc. will then be responsible for adding the port you create to the Virtual Workflow application running on the server. When the application is started, the actions in the specified workflow are executed. Virtual Workflow keeps track of the time at which each action takes place.

“Run Virtual Workflow” will allow a user to initiate a new workflow session from the current one. The Virtual Workflow action will have to be configured with a terminus (UC group), contact type (voice, email, IM), and User Data (parameter passed into the workflow session).

Add Active Workflow

The screenshot shows a dialog box titled "4: Add Active Workflow" with a close button (X) in the top right corner. The dialog contains the following fields and controls:

- Action Name:** A text field containing "Add Active Workflow" and a "Set Default" button.
- Object:** A dropdown menu.
- DN to Connect:** A dropdown menu.
- Mode:** Radio buttons for "Call" (selected) and "User".
- User:** Checkboxes for "Inbound RTP" and "Outbound RTP".
- Caller:** Checkboxes for "Inbound RTP" and "Outbound RTP".
- Reference ID:** A dropdown menu.
- On Success Go To:** A dropdown menu.
- On Failure Go To:** A dropdown menu.
- Link Name:** Two text input fields, one for each "Go To" dropdown.
- Hide Incoming Links:** A checkbox.
- Log Action:** A checkbox.
- Buttons:** "OK" and "Cancel" buttons at the bottom right.

The Active Workflow feature allows the administrator to listen to an active workflow and allows the administrator to identify particularities that they search for on the call. Using the Active Workflow during a call will allow you to create several new classes of applications, for example:

- **Real-time speech analytics:** allows you to run speech recognition in a loop or hierarchy on a call, and look for words and phrases that might change how the call is handled. This could include notifying a user, triggering recording, or updating a call script.
- **Secure credit card capture:** By capturing DTMF from a caller, but not routing it to a user, callers can provide credit card numbers to users without the users knowing the number, and without the DTMF being recorded.
- **Star Codes/speech-based commands:** a workflow listening for a user's DTMF commands could capture star codes to transfer, consult, and hold the call, but could also use a star code as a way to modify audio routes and take spoken commands inline.

Add Active Workflow	
Option	Description
Action Name	By default, this field shows 'Add Active Workflow.' You can change this by clearing the field and typing a more descriptive name.
Set Default	<p>A button used to generate a new action name based on the properties selected for the action.</p> <p>For this action, the default name is determined by the parameter type, parameter name, and the variable in which the parameter value is stored. The action name is updated when Set Default is clicked.</p>
Object	A dropdown list of object variables you have already created. Select the object variable that represents the contact that you want to add to Active Workflow.
DN to Connect	This will take the form of a SIP URI (UC Address) specified in iceAdministrator. The connected ice user id will have a set of user parameters (;iceSwitchID = <SWITCHID> ,iceAgentID = <AGENTID>) added to the URI of the active workflow application. These should be passed through to the destination app to let it identify which user is handling the call. In a per-call active workflow, these URI parameters will be for the first agent connected to the call while in the per-agent case, these will be the parameters of the currently connected agent.
Mode	The mode can be per call or per agent. In the per call mode, the DN is connected once at the beginning of the call and is maintained until the call ends. In the per agent mode, the DN is connected for the first agent to join the call and again for any other agent joining the call through a consult or conference.

Add Active Workflow	
Option	Description
Inbound RTP (Caller, Agent, Both)	<p>An active workflow session may receive RTP from either side of the call. For the purposes of the per-call active workflow, agent audio includes consulted parties. Caller audio will only be the inbound caller stream.</p> <p>Note: Two active workflows can be added to independently listen to each side of the call, and three or more active workflows can be active for a per-agent active workflow. For the per-agent active workflow, if agent RTP is selected, only the audio from a single agent endpoint is sent to the workflow application.</p>
Outbound RTP (Caller, Agent, Both)	<p>An active workflow can also play media to a caller, an agent, or both endpoints. This can be used for application-based coaching or whisper, which could include interactive responses.</p>
Reference ID	<p>An output field to store the unique ID for the active workflow session to be used in the Remove Active Workflow action.</p>
On Success Go To	<p>A dropdown list of all other actions that have been placed on the workflow page. The contact is directed to this action once the Add Active Workflow parameter has been set.</p>
On Failure Go To	<p>A dropdown list of all other actions that have been placed on the workflow page. The contact is directed to this action if an invalid parameter name has been specified.</p>
Link Name	<p>Optional fields that allow you to label the links that appear between this action and the actions selected from the 'Go To' dropdown lists.</p>
Hide Incoming Links	<p>An optional checkbox that allows you to hide the incoming links for this action. For more information, refer to Hiding Incoming Links on page 31.</p>
Log Action	<p>An optional checkbox that allows you to log information about this action. For more information, refer to Logging Activity for an Action on page 44.</p>

Remove Active Workflow

5: Remove Active Workflow

Action Name:

Object:

Variable:

On Success Go To Link Name

On Failure Go To Link Name

Hide Incoming Links

Log Action

The Remove Active Workflow action can be used by entering the returned ID and will remove an active workflow session from the active call.

Remove Active Workflow	
Option	Description
Action Name	By default, this field shows 'Add Active Workflow.' You can change this by clearing the field and typing a more descriptive name.
Set Default	A button used to generate a new action name based on the properties selected for the action. For this action, the default name is determined by the parameter type, parameter name, and the variable in which the parameter value is stored. The action name is updated when Set Default is clicked.
Object	A dropdown list of object variables you have already created. Select the object variable that represents the contact that you want to remove from Active Workflow.

Remove Active Workflow	
Option	Description
Variable	The Variable field should contain the Reference ID that was returned from Add Active Workflow.
On Success Go To	A dropdown list of all other actions that have been placed on the workflow page. The contact is directed to this action once the Add Active Workflow parameter has been set.
On Failure Go To	A dropdown list of all other actions that have been placed on the workflow page. The contact is directed to this action if an invalid parameter name has been specified.
Link Name	Optional fields that allow you to label the links that appear between this action and the actions selected from the 'Go To' dropdown lists.
Hide Incoming Links	An optional checkbox that allows you to hide the incoming links for this action. For more information, refer to Hiding Incoming Links on page 31.
Log Action	An optional checkbox that allows you to log information about this action. For more information, refer to Logging Activity for an Action on page 44.



Chapter 8: Database Actions

Each workflow action has a distinct set of properties that you must complete when designing workflow. When an action's properties are incomplete, the icon appears on the workflow page with a red background. Any changes that you have made in iceAdministrator cannot be saved until all properties are completed.

This chapter describes each of the database workflow actions, including the input fields, buttons, checkboxes, and radio buttons. Use this chapter as a reference for completing required and optional fields for each database action type. You may also wish to use this chapter as a reference when modifying database actions. Refer to the Database Workflow Actions table for a brief description of each database action and for a page reference to the appropriate section within this chapter.







This chapter assumes that you are familiar with viewing workflow and that you have created a workflow page and placed the required actions on the workflow page. For information on the tasks associated with creating a workflow page and adding actions, refer to Chapter 1: Introduction to Workflow.

This chapter also assumes some familiarity with relational databases and Structured Query Language (SQL).

Caution: It is highly recommended to modify workflow outside of regular hours or peak hours. Place a test call or send a test email or IM message (as required) to your contact center after changes are saved to ensure that workflow is functioning properly.

Database Workflow Actions Defined

Database actions are premium actions specifically designed to handle database connectivity and database queries, as shown in the table below:

Database Workflow Actions			
Action	Description	Icon	Page
DB Connect	Connects workflow with a database and opens the database handle. The database can then queried or updated using the other database workflow actions.		359
DB Execute Query	Sends a query to a database and opens a query handle to manage the query results, if any.		362
DB Next Record	Iterates through the records returned from a DB Execute Query action and allows you to store the results in variables.		366
DB Begin Transaction	Starts a transaction with the specified database. Also specifies what to do if the database handle is closed before the End Transaction action is executed in the workflow.		369
DB End Transaction	Commits or rolls back any changes made to a database since the last DB Begin Transaction in the workflow.		371
DB Close Handle	Closes the database handle (and any associated query handles).		373

DB Connect

DB Connect opens a connection to a database and creates a database handle that remains open until the DB Close Handle action is used or the caller hangs up. The database handle is stored in a variable that can then be used for the other database actions in the workflow. Note that an error occurs if the DB Connect action attempts to create a database handle using a variable that is already associated with a currently open database handle.

The table below describes the fields on the DB Connect properties dialog box:

DB Connect	
Option	Description
DB Connect	By default, this field shows 'DB Connect.' You can change this by clearing the field and typing a more descriptive name.

DB Connect	
Option	Description
Set Default	<p>A button used to generate a new action name based on the properties selected for the action.</p> <p>For this action, the default name is determined by the ODBC data source name. The action name is updated when <i>Set Default</i> is clicked (e.g., 'DBConnect - @HostDatabase').</p>
ODBC Data Source Name	<p>The name of the ODBC entry that links to the database to which you want to connect. You can type in the name, select a variable from the list, or create a new variable by selecting '<NEW VARIABLE>' from the list.</p> <p>Note: ODBC entries are added in Start > Settings > Control Panel > Administrative Tools > Data Sources (ODBC). The data source specified MUST exist on the ice server itself.</p>
User ID	<p>The user ID used to connect to the database. You can type in the user ID, select a variable from the list, or create a new variable by selecting '<NEW VARIABLE>' from the list.</p>
Password	<p>The password used to connect to the database. You can type in the password, or select the 'Use Variable' checkbox to select a variable from the dropdown list (or create a new variable by selecting '<NEW VARIABLE>' from the list).</p>
Timeout	<p>The number of seconds before the attempt to connect to the database times out. You can type in a numerical value, select a variable from the list, or create a new variable by selecting '<NEW VARIABLE>' from the list. The default is 30 seconds.</p>
Assign DB Handle to Variable	<p>Select the variable to which you want to assign the database handle – this variable is used in the other database actions for this particular database connection. You can create a new variable by typing the name of the variable directly into the field or by selecting '<NEW VARIABLE>' from the dropdown list.</p>
Go To	<p>A dropdown list of all the other actions that have been placed on the page. Select the action that is next in the workflow sequence.</p>

DB Connect	
Option	Description
On Error Go To	A dropdown list of all the other actions that have been placed on the page. Select the action that is next in the workflow sequence should the connection to the database fail.
Link Name	Optional fields that allow you to label the links that appear between this action and the actions selected in the 'Go To' dropdown lists.
Hide Incoming Links	An optional checkbox that allows you to hide the incoming links for this action. For more information, refer to Hiding Incoming Links on page 38.
Log Action	An optional checkbox that allows you to log information about this action. For more information, refer to Logging Activity for an Action on page 44.

DB Execute Query

51: DB Execute Query

Action Name:

Input

Database Handle:

Timeout (seconds):

SQL Query SQL Statement

Query

Variable:

Use SQL Parameters

Name	Type	Value
------	------	-------

Output

Assign Query Handle to Variable:

Assign Row Count to Variable:

Go To: Link Name:

On Error Go To: Link Name:

Hide Incoming Links

Log Action

DB Execute Query is used to either update the database or to retrieve information from it. If the database query returns a set of results, these are managed by a query handle that is assigned to a variable. The individual records from each column in the results set can then be placed into a variable by using the DB Next Record action.

If you pass a rowcount return variable to DB Execute Query, the action will use a 'static' cursor to process the query. For MSSQL drivers, rowcounts are available only when using static cursors. If using DB Execute Query to call stored procedures with more than a simple query (stored procedures with multiple select statements or declared variables), these queries are unable to return any row count, and they may fail when using a static cursor. For this reason, the caller can remove the rowcount variable, and this will cause the query to be executed with a 'forward only' cursor. In general, if a query fails or fails to generate any data and a rowcount is being requested, the query should be tried again without a rowcount variable. In either case, rowcount should not be used to determine if any data has been returned. To determine if data has been returned use the DB Next Record action to determine if there is data available. If data is available, DB Next

Record will move to the next record, and you can use it to retrieve the data. If no data is available, the action will follow the 'On End of Set Go To' link.

The table below describes the fields on the DB Execute Query properties dialog box:

DB Execute Query	
Option	Description
Action Name	By default, this field shows 'DB Execute Query.' You can change this by clearing the field and typing a more descriptive name.
Set Default	A button used to set the default action name. For this action, the default name is 'DB Execute Query.'
Database Handle	Select the variable representing the database handle from the dropdown list. You can create a new variable by selecting '<NEW VARIABLE>' from the list. This field must contain the database handle from the DB Connect action.
Timeout	The number of seconds spent waiting for a reply to the database query before the request times out. You can type in a numerical value, select a variable from the list, or create a new variable by selecting '<NEW VARIABLE>' from the list. The default is 30 seconds.
SQL Query/SQL Statement	Select the 'SQL Query' or 'SQL Statement' radio button. The 'SQL Query' option is selected by default. This option is used to enter a SQL statement that will return information from the database (e.g., a SELECT statement). The 'SQL Statement' option is used if you are writing information to the database but are not requesting any data in return (e.g., an UPDATE statement).
Query	The query that will be sent to the database. You can enter a SQL statement, variables, or a combination thereof.
Variable/Insert	To insert a variable into the 'Query' field, select it from the dropdown list or select '<NEW VARIABLE>' to create a new variable. Click <i>Insert</i> .

DB Execute Query	
Option	Description
Use SQL Parameters	An optional checkbox that allows you to use SQL Parameters.
Assign Query Handle to Variable	Select the variable to which you want to assign the query handle – this variable is used in the other DB Next Record action for this particular database connection. You can create a new variable by typing the name of the variable directly into the field or by selecting '<NEW VARIABLE>' from the dropdown list. This field is enabled and required if you selected the 'SQL Query' query type above.
Assign Row Count to Variable	Select the variable to which you want to assign the row count. For the 'SQL Query' query type, this value represents the number of rows returned. For the 'SQL Statement' query type, this value represents the number of rows affected by the statement. You can create a new variable by typing the name of the variable directly into the field or by selecting '<NEW VARIABLE>' from the dropdown list. Note: This field is disabled for SQL queries.
Go To	A dropdown list of all the other actions that have been placed on the page. Select the action that is next in the workflow sequence.
On Error Go To	A dropdown list of all the other actions that have been placed on the page. Select the action that is next in the workflow sequence should an error occur with this action (for example, if the database handle specified is not currently open).
Link Name	Optional fields that allow you to label the links that appear between this action and the actions selected in the 'Go To' dropdown lists.
Hide Incoming Links	An optional checkbox that allows you to hide the incoming links for this action. For more information, refer to Hiding Incoming Links on page 38.

DB Execute Query	
Option	Description
Log Action	An optional checkbox that allows you to log information about this action. For more information, refer to Logging Activity for an Action on page 44.

DB Next Record

DB Next Record is used to iterate through the records of a set of results that have come from a DB Execute Query action and to copy the column entries from each record into variables for future use. You do not have to include all the columns from which data was pulled from the database, but you cannot include columns that were not included in the original query.

The table below describes the fields on the DB Next Record properties dialog box:

DB Next Record	
Option	Description
Action Name	By default, this field shows 'DB Next Record.' You can change this by clearing the field and typing a more descriptive name.

DB Next Record	
Option	Description
Set Default	A button used to set the default action name. For this action, the default name is 'DB Next Record.'
Query Handle	Select the variable representing the query handle from the dropdown list. You can create a new variable by selecting '<NEW VARIABLE>' from the list. This field must contain the query handle from the DB Execute Query action preceding the DB Next Record action in the workflow.
Column Name	Type in the name of the column for which you want to retrieve the record set. You can also select a variable from the dropdown list or create a new variable by selecting '<NEW VARIABLE>' from the list. Add or remove columns from the list by using the <i>Add/Remove</i> buttons described below. Note: If the original query in the DB Execute Query action specified a column name that is different from the database table column name, (e.g., "SELECT name AS firstname") you must use the new column name (e.g., "firstname").
Variable	Select the variable representing the column name record from the dropdown list. You can create a new variable by typing the name of the variable directly into the field or by selecting '<NEW VARIABLE>' from the list.
Add/Remove	Click <i>Add</i> to add the column and variable to the list. To remove a column/variable from the list, highlight the row and then click <i>Remove</i> .
Go To	A dropdown list of all the other actions that have been placed on the page. Select the action that is next in the workflow sequence. This workflow will most likely perform some functions using the column variables and then return to the DB Next Record Action to get the next set of variables.
On End of Set Go To	A dropdown list of all the other actions that have been placed on the page. When the last row in the results set is reached, select the action that will come next in workflow, e.g., DB Close Handle).

DB Next Record	
Option	Description
On Error Go To	A dropdown list of all the other actions that have been placed on the page. Select the action that is next in the workflow sequence should an error occur with this action (for example, if one of the column names specified is not part of the actual query result set).
Link Name	Optional fields that allow you to label the links that appear between this action and the actions selected in the 'Go To' dropdown lists.
Hide Incoming Links	An optional checkbox that allows you to hide the incoming links for this action. For more information, refer to Hiding Incoming Links on page 38.
Log Action	An optional checkbox that allows you to log information about this action. For more information, refer to Logging Activity for an Action on page 44.

DB Begin Transaction

DB Begin Transaction is used to start a transaction on the database. An error occurs if there is already a transaction in progress on the specified database. To end a database transaction, use the DB End Transaction action.

The table below describes the fields on the DB Begin Transaction properties dialog box:

DB Begin Transaction	
Option	Description
Action Name	By default, this field shows 'DB Begin Transaction.' You can change this by clearing the field and typing a more descriptive name.
Set Default	A button used to set the default action name. For this action, the default name is 'DB Begin Transaction.'
DB Handle	Select the variable representing the database handle from the dropdown list. You can create a new variable by selecting '<NEW VARIABLE>' from the list. This field must contain the database handle from the DB Connect action.

DB Begin Transaction	
Option	Description
Default Action on Close	Select the 'Commit' or 'Rollback' radio button. If you commit, any changes made by the Execute Query action are saved to the database. If you select 'Rollback,' the changes are not saved. These options come into effect only if the database handle is closed in workflow or if the caller hangs up before the contact reaches the DB End Transaction action.
Go To	A dropdown list of all the other actions that have been placed on the page. Select the action that is next in the workflow sequence.
On Error Go To	A dropdown list of all the other actions that have been placed on the page. Select the action that is next in the workflow sequence should an error occur with this action (for example, if there is already a transaction in progress on the database).
Link Name	Optional fields that allow you to label the links that appear between this action and the actions selected in the 'Go To' dropdown lists.
Hide Incoming Links	An optional checkbox that allows you to hide the incoming links for this action. For more information, refer to Hiding Incoming Links on page 38.
Log Action	An optional checkbox that allows you to log information about this action. For more information, refer to Logging Activity for an Action on page 44.

DB End Transaction

DB End Transaction is used to either commit or rollback changes to the database that has occurred since the last call to DB Begin Transaction.

The table below describes the fields on the DB End Transaction properties dialog box:

DB End Transaction	
Option	Description
Action Name	By default, this field shows the 'DB End Transaction.' You can change this by clearing the field and typing a more descriptive name.
Set Default	A button used to set the default action name. For this action, the default name is 'DB End Transaction.'
DB Handle	Select the variable representing the database handle from the dropdown list. You can create a new variable by selecting '<NEW VARIABLE>' from the list. This field must contain the database handle from the DB Connect action.
Commit/Rollback	Select the 'Commit' or 'Rollback' radio button. If you commit, any changes made by the DB Execute Query action are saved to the database. If you select 'Rollback,' the changes are not saved.

DB End Transaction	
Option	Description
Go To	A dropdown list of all the other actions that have been placed on the page. Select the action that is next in the workflow sequence.
On Error Go To	A dropdown list of all the other actions that have been placed on the page. Select the action that is next in the workflow sequence should an error occur with this action (for example, if there is no transaction to end).
Link Name	Optional fields that allow you to label the links that appear between this action and the actions selected in the 'Go To' dropdown lists.
Hide Incoming Links	An optional checkbox that allows you to hide the incoming links for this action. For more information, refer to Hiding Incoming Links on page 38.
Log Action	An optional checkbox that allows you to log information about this action. For more information, refer to Logging Activity for an Action on page 44.

DB Close Handle

DB Close Handle is used to close an open database handle in the workflow. This action explicitly closes the handle, which ends the connection to the database. If you close the database handle, all associated query handles and transactions will be closed. The database handle is also automatically closed when the call is ended. This could happen at any point in the workflow, for example, if the caller hangs up.

The table below describes the fields on the DB Close Handle properties dialog box:

DB Close Handle	
Option	Description
Action Name	By default, this field shows 'DB Close Handle.' You can change this by clearing the field and typing a more descriptive name.
Set Default	A button used to set the default action name. For this action, the default name is 'DB Close Handle.'
DB Handle	Select the variable representing the database handle from the dropdown list. You can create a new variable by selecting '<NEW VARIABLE>' from the list. If you select a variable that is not currently an open database handle, this action is essentially ignored in the workflow.
Go To	A dropdown list of all the other actions that have been placed on the page. Select the action that is next in the workflow sequence.

DB Close Handle	
Option	Description
Link Name	Optional fields that allow you to label the links that appear between this action and the actions selected in the 'Go To' dropdown lists.
Hide Incoming Links	An optional checkbox that allows you to hide the incoming links for this action. For more information, refer to Hiding Incoming Links on page 38.
Log Action	An optional checkbox that allows you to log information about this action. For more information, refer to Logging Activity for an Action on page 44.



Chapter 9: Email Actions

Each workflow action has a distinct set of properties that you must complete when designing workflow. When an action's properties are incomplete, the icon appears on the workflow page with a red background. Any changes that you have made in iceAdministrator cannot be saved until all properties are completed.

This chapter describes each of the email workflow actions, including the input fields, buttons, checkboxes and radio buttons. Use this chapter as a reference for completing required and optional fields for each email action type. You may also wish to use this chapter as a reference when modifying email actions. Refer to the Email Workflow Actions table for a brief description of each email action and for a page reference to the appropriate section within this chapter.

Note: All email actions, with the exception of the Send Email action, require the iceMail add-on for ice. Please contact ComputerTalk Technology, Inc. for more information.

Email messages can either be routed to a queue or can be routed to an individual user. Consider the examples below:

- Messages sent to support@abccompany.com are directed to the Support queue, where the message will be handled by the first available user.
- A reply to an email thread (i.e., a user responded to a message, and the customer is sending a reply to the user's message) can be routed to the user that first handled the email message.

This chapter assumes that you are familiar with viewing workflow and that you have created a workflow page and placed the required actions on the workflow

page. For information on the tasks associated with creating a workflow page and adding actions, refer to Chapter 1: Introduction to Workflow.



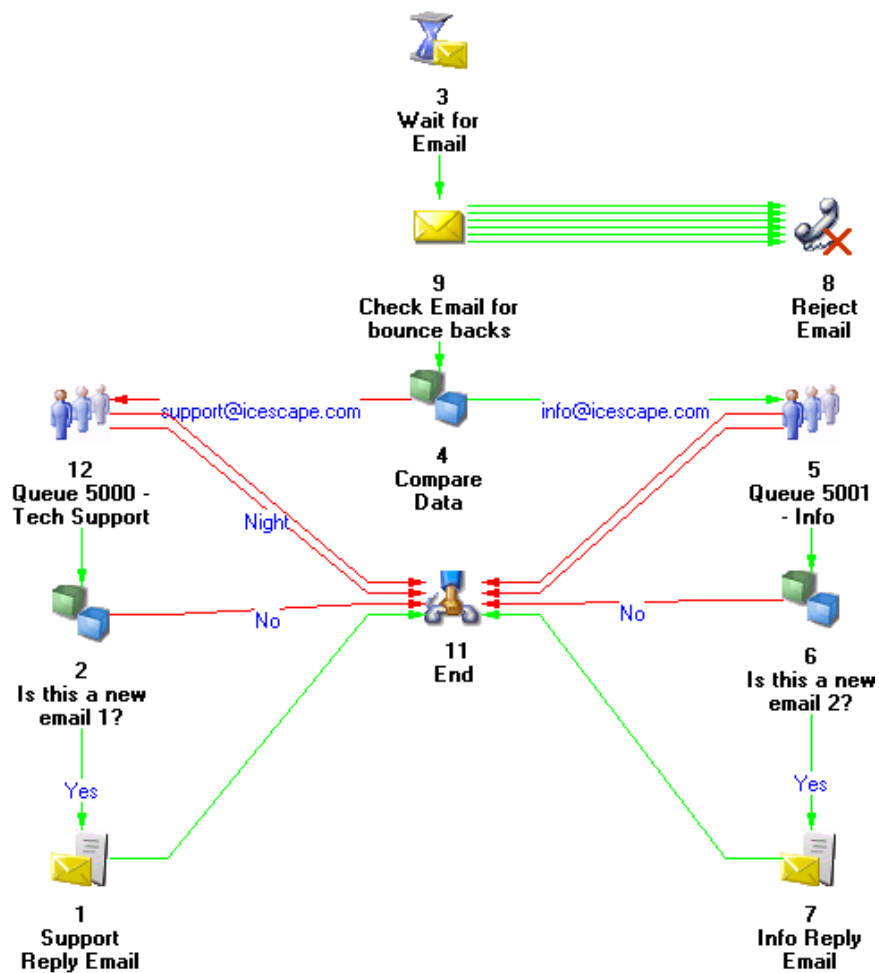

Caution: It is highly recommended to modify workflow outside of regular hours or peak hours. Send a test email message to your contact center after changes are saved to ensure that workflow is functioning properly.

The figure below shows an example of a workflow that can be created for email messages.



Email Workflow Actions Defined

Email actions are premium actions specifically designed to handle email messages sent to your contact center, as described in the table below:

Email Workflow Actions			
Action	Description	Icon	Page
Check Email	Check an incoming email message for keywords in the heading or the body of the message. Email messages can be routed to a distinct workflow path based on these keywords. For example, send a message with the keyword "help" to a technical support queue.		378
Compose Reply	Automatically send a response to an incoming email. This feature might be used to send a confirmation email to a customer (e.g., We have received your message and are processing your request).		381
Send Email	Send an email message. For example, you can use this action to send email notifications to users when calls are forwarded to their voicemail DN.		383
Wait for Email	Wait for an inbound email. When the email arrives, it is assigned to an object and then routed the next action. This action is the starting point of workflow for email messages.		387

Check E-mail

22: Check Email

Action Name:

Field	Text to Search for	Go To	Link Name
SUBJECT	<input type="text"/>	<input type="text"/>	<input type="text"/>

Field	Text	Go To	Link Name

If No Match Go To:
 Link Name:

Hide Incoming Links
 Log Action

Check E-mail can give incoming messages a distinct treatment based on conditions you create. If an email does not match any of the conditions you create, it is sent on a default workflow path. Consider the following examples of conditions that can be added to the Check Email table:

- Scan for a keyword in the body of the email message, and route the caller to the appropriate action. For example, you might scan for the word 'help' and direct the caller to a technical support queue.
- Scan for a keyword in the subject of the email message, and route the caller to the appropriate action. For example, you might scan for the word 'complaint' and direct the caller to a customer service queue.
- Scan for a particular sender's email address, and route the caller to the appropriate action. Priority contacts can be directed to a priority queue.
- Scan for the address to which the email was sent, and route the caller to the appropriate action. This option is helpful if your contact center has multiple email accounts. For example, email messages sent to support@icescape.com can be directed to a technical support queue.

This action can use the following wildcards:

- '?' represents any single character. For example, 'c?t' could represent 'cat' or 'cot.'
- '*' represents any number of characters. For example '*spell' could represent 'spell' or 'misspell.'
- '\' indicates that the next character should not be treated as a special character. For example, '*.exe' could be used to search the body of the email for '*.exe.'

Note: If you type '*?' the question mark is not treated as a special symbol. Similarly, if you type '**', the second asterisk is not treated as a special symbol. To search for a '\' use '\\' in the search string.

The table below describes the fields and buttons found on the properties dialog box for Check E-mail.

Check Email	
Option	Description
Action Name	By default, this field shows 'Check Email.' You can change this by clearing the field and typing a more descriptive name.
Set Default	A button used to set the default action name. For this action, the default name is 'Check Email.'
Field	A dropdown list with the following options: Body, Recipient, Sender, and Subject.
Text to Search for	A dropdown list of existing data variables, as well as system variables. You can create a new variable by selecting '<NEW VARIABLE>' from the list. You may also type a static value in this field. The value of the variable must represent the text or email address for which you are scanning.
Go To	A dropdown list of all other actions that have been placed on the workflow page. Contacts are directed to the action you select when a match is found for the text.
Add	Once you have created a condition by populating the 'Field,' 'Text to Search for' and 'Go To' fields, use <i>Add</i> to add the condition to the table.
Remove	A button used to remove a condition from the table. The condition must be highlighted before it can be removed.

Check Email	
Option	Description
Up /Down	Buttons used to move a row, or condition, to a new position in the table. The condition must be highlighted before it can be moved.
If no match go to	A dropdown list of all other actions that have been placed on the workflow page. Contacts are directed to the action you select if they do not meet any of the conditions that have been added to the table.
Link Name	Optional fields that allow you to label the links that appear between this action and the actions selected from the 'Go To' dropdown lists.
Hide Incoming Links	An optional checkbox that allows you to hide the incoming links for this action. For more information, refer to Hiding Incoming Links on page 38.
Log Action	An optional checkbox that allows you to log information about this action. For more information, refer to Logging Activity for an Action on page 44.

Compose Reply

Compose Reply allows you to send an instant reply to any email message that has arrived at your contact center. For example, an instant reply can inform the sender that the message has been received and a response from a customer service representative will be provided within 24 hours.

The table describes the fields and buttons found on the properties dialog box for Compose Reply.

Compose Reply	
Option	Description
Action Name	By default, this field shows 'Compose Reply.' You can change this by clearing the field and typing a more descriptive name.
Set Default	A button used to set the default action name. For this action, the default name is 'Compose Reply.'
Variable	A dropdown list showing system variables and data variables.
Insert	A button used to insert the selected variable into the reply message. You may insert any number of variables into a message.

Compose Reply	
Option	Description
<Message Text>	Enter the text that you want to be included in the email message in the large text box. You can insert a variable into the message by selecting a variable from the dropdown list and clicking <i>Insert</i> . The value of the variable is included in the email message that is sent.
Go To	A dropdown list of all other actions that have been placed on the workflow page. Contacts are directed to the action after the reply message is sent.
Link Name	An optional field allowing you to label the link that appears between this action and the action selected from the 'Go To' dropdown list.
Hide Incoming Links	An optional checkbox that allows you to hide the incoming links for this action. For more information, refer to Hiding Incoming Links on page 38.
Log Action	An optional checkbox that allows you to log information about this action. For more information, refer to Logging Activity for an Action on page 44.

Send Email

Send Email allows you to send an email message in the workflow. For example, you may want to set up automated messages that follow up on calls or to send email notifications to users when calls are forwarded to their voicemail DN.

Note: You do not require the iceMail add-on to use this action.

The table describes the fields and buttons found on the properties dialog box for Send Email.

Send Email	
Option	Description
Action Name	By default, this field shows 'Wait for Email.' You can change this by clearing the field and typing a more descriptive name.

Send Email	
Option	Description
Set Default	<p>A button used to generate a new action name based on the properties selected for the action.</p> <p>For this action, the default name is determined by the "to" address. The action name is updated when <i>Set Default</i> is clicked (e.g., 'Email @Support').</p>
Server	<p>The name of the server for sending emails. You can type in the name or IP address of the server, select a variable from the dropdown list, or create a new variable by selecting '<NEW VARIABLE>' from the list.</p>
Port	<p>Enter the SMTP port of the email server.</p>
Use Default	<p>Select "Use Default" if to use the default SMTP port, which is port 25 for non-encrypted sends and port 465 for encrypted sends.</p>
Use SSL	<p>Select "Use SSL" for encrypted SMTP sessions.</p>
User Name	<p>If needed, you can enter a username for authentication on the email server. You can type in a value, select a variable from the dropdown list, or create a new variable by selecting '<NEW VARIABLE>' from the list.</p>
Password	<p>If needed, you can enter a password for authentication on the email server. You can type in a value, select a variable from the dropdown list, or create a new variable by selecting '<NEW VARIABLE>' from the list under "Use Variable."</p>
Body	<p>The content of the email message. You can enter text, a variable, or a combination thereof.</p>
Variable/Insert	<p>To insert a variable into the 'Body' field, select it from the dropdown list or select '<NEW VARIABLE>' to create a new variable. Click <i>Insert</i>.</p> <p>Note: You can only access the dropdown list by checking the Use Variable checkbox. Otherwise, you must type in the password into the "Password" text field if it does not take variables.</p>

Send Email	
Option	Description
To (Name)	<p>The name of the email message receiver. This is displayed in the 'To' field of the email message. You can type in a name, select a variable from the dropdown list, or create a new variable by selecting '<NEW VARIABLE>' from the list. You can list multiple names by separating each name with a semicolon. To make sure that multiple 'To' names are mapped to the appropriate 'To' addresses, list them in the same order as the 'To' addresses below.</p> <p>For example: To (Name): Bob;Fred;Mary</p>
To (Address)	<p>The destination email address. You can type in an email address, select a variable from the dropdown list, or create a new variable by selecting '<NEW VARIABLE>' from the list. You can send the email to multiple addresses by separating each address with a semicolon. To make sure that multiple 'To' addresses are mapped to the appropriate 'To' names, list them in the same order as the 'To' names above.</p> <p>For example To (Address): Bob@abc.com;Fred@abc.com;Mary@xyz.com</p>
From (Name)	<p>The name of the email message sender. This will be displayed in the 'From' field of the email message. You can type in a name, select a variable from the dropdown list, or create a new variable by selecting '<NEW VARIABLE>' from the list.</p>
From (Address)	<p>The originating email address. You can type in an email address, select a variable from the dropdown list, or create a new variable by selecting '<NEW VARIABLE>' from the list.</p>
Reply To (Name)	<p>The name of the person to whom a reply should be sent, if this is different from the 'From (Name).' This will be displayed in the 'From' field of the email message. You can type in a name, select a variable from the dropdown list, or create a new variable by selecting '<NEW VARIABLE>' from the list.</p>

Send Email	
Option	Description
Reply To (Address)	The email address account to which you want replies to this message sent, if it is different from the 'From (Address).' You can type in an email address, select a variable from the dropdown list, or create a new variable by selecting '<NEW VARIABLE>' from the list.
Attachment	Type in the pathname of the file you want to attach to the message. You can also select a variable from the dropdown list or create a new variable by selecting '<NEW VARIABLE>' from the list. Add or remove rows from the list by using the <i>Add/Remove</i> buttons described below.
Add/Remove	Click <i>Add</i> to add the attachment to the list. To remove an item from the list, highlight the row and then click <i>Remove</i> .
Go To	A dropdown list of all the other actions that have been placed on the page. Select the action that is next in the workflow sequence.
On Error Go To	A dropdown list of all the other actions that have been placed on the page. Select the action that is next in the workflow sequence should an error occur with sending the email.
Link Name	Optional fields that allow you to label the links that appear between this action and the actions selected in the 'Go To' dropdown lists.
Hide Incoming Links	An optional checkbox that allows you to hide the incoming links for this action. For more information, refer to Hiding Incoming Links on page 3838.
Log Action	An optional checkbox that allows you to log information about this action. For more information, refer to Logging Activity for an Action on page 44.

Wait for Email

Wait for Email is typically the starting point for workflow designed for email messages. This action gathers information about the message sender, which is stored in system variables. This information includes the email address to which the message is sent, the email address of the sender, and much more. For more information on system variables, refer to page 15.

The table below describes the fields and buttons found on the properties dialog box for Wait for Email:

Wait for Email	
Option	Description
Action Name	By default, this field shows 'Wait for Email.' You can change this by clearing the field and typing a more descriptive name.
Set Default	A button used to set the default action name. For this action, the default name is 'Wait for Email.'
Wait Options	'Wait Forever' is the default setting. Selecting 'Wait for timeout of' allows you to enter the number of seconds, or select a variable from the dropdown list. Select '<NEW VARIABLE>' to create a variable. When this timeout threshold is met, workflow looks to the action specified in the field 'On Timeout Go To.'

Wait for Email	
Option	Description
Assign to Object	A dropdown list of object variables you have already created. You can create a new variable by typing the name of the variable directly into the field or by selecting '<NEW VARIABLE>' from the list.
On Success Go To	A dropdown list of all other actions that have been placed on the workflow page. All contacts are directed to the action you select from this list.
On Timeout Go To	A dropdown list of all other actions that have been placed on the workflow page. This field is available if you have selected 'Wait for time of' as the wait option.
Link Name	Optional fields that allow you to label the links that appear between this action and the actions selected from the 'Go To' dropdown lists.
Hide Incoming Links	An optional checkbox that allows you to hide the incoming links for this action. For more information, refer to Hiding Incoming Links on page 38.
Log Action	An optional checkbox that allows you to log information about this action. For more information, refer to Logging Activity for an Action on page 44.

Managing User Routing

Standard workflow treatment of inbound email objects is to queue the object and send to the next available user. If the email thread has been handled by a particular user previously, this can be treated differently in the workflow to route the object directly to that user if they are available.

The system variable `$Email:IntendedUserID` contains the User ID of the last user to have handled a particular email thread. If this is the initial email in the thread, then this value is 0. Optionally, workflow actions can be used to evaluate this value and route inbound replies to that User ID.

Failed routings in cases where this User ID has been deleted, or the intended user is not logged on can be handled by workflow, typically by re-queuing for next available user. Further sophisticated routing can be invoked by querying the state of `$Email:IntendedUserID` and making decisions based upon the returned user state. For example, the treatment could be different if the user is Not Ready, Ready, On Call, Wrap Up, etc. For more information on this refer to the section on User Control:Get Property starting on page 265 in Chapter 7: Advanced Options.

By default, if an email object is routed to a user who is Logged On, but Not Ready, the email will be placed in their PAQ. If this is not the desired result, then the desired outcome must be implemented through the workflow.



Chapter 10: IM Actions

Each workflow action has a distinct set of properties that you must complete when designing workflow. When an action's properties are incomplete, the icon appears on the workflow page with a red background. Any changes that you have made in iceAdministrator cannot be saved until all properties are completed.

This chapter describes each of the IM workflow actions, including the input fields, buttons, checkboxes and radio buttons. Use this chapter as a reference for completing required and optional fields for each IM action type. You may also wish to use this chapter as a reference when modifying IM actions. Refer to the IM Workflow Actions table for a brief description of each IM action and for a page reference to the appropriate section within this chapter.



Note: All IM actions require the Instant Message add-on for ice. Please contact ComputerTalk Technology, Inc. for more information.

This chapter assumes that you are familiar with viewing workflow and that you have created a workflow page and placed the required actions on the workflow page. For information on the tasks associated with creating a workflow page and adding actions, refer to Chapter 1: Introduction to Workflow.

Caution: It is highly recommended to modify workflow outside of regular hours or peak hours. Send a test instant message to your contact center after changes are saved to ensure that workflow is functioning properly.

IM Workflow Actions Defined

IM actions are premium actions specifically designed to handle instant messages sent to your contact center, as described in the table below:

IM Workflow Actions			
Action	Description	Icon	Page
Receive Instant Message	Wait for a sender response. The text of the sender's response is stored in a variable, which can then be used to make decisions about routing the contact in the workflow.		378
Reply Instant Message	Automatically send a response to an incoming instant message. This feature might be used to send a confirmation to the sender, or to provide more information or options to the sender (e.g., We have received your support request. Enter 1 for hardware support, or enter 2 for software support).		381
Wait for Instant Message	Wait for an inbound instant message session. When the first instant message of a session arrives, it is assigned to an object and then routed the next action. This action is the starting point of workflow for instant messages.		387

Receive Instant Message

Receive Instant Message is used to “listen” for instant messages from the sender. Consider the following examples of this action in use:

- The sender’s message is received. The ‘Include message in session log sent to user’ checkbox is enabled. The message is then queued. The next available user receives the instant message from the queue with the original text from the sender.
- The sender’s message is received. The sender is then sent a reply (using the Reply Instant Message action) with a list of options. The Receive Instant Message action is used again in the workflow to wait for the sender’s response and (using additional actions) route the caller accordingly.

The table below describes the fields and buttons found on the properties dialog box for Receive Instant Message.

Receive Instant Message	
Option	Description
Action Name	By default, this field shows ‘Receive Instant Message.’ You can change this by clearing the field and typing a more descriptive name.
Set Default	A button used to set the default action name. For this action, the default name is ‘Receive Instant Message.’

Receive Instant Message	
Option	Description
Timeout	<p>The timeout duration determines how long (in milliseconds) the action waits for the instant message before the 'On Timeout Go To' link is followed.</p> <p>You can specify the timeout threshold in milliseconds, select INFINITE from the dropdown list, or select a variable from the dropdown list. Select '<NEW VARIABLE>' to create a variable.</p>
Store Message in Variable	<p>A dropdown list of existing data variables. You can create a new variable by typing the name of the variable directly into the field or by selecting '<NEW VARIABLE>' from the list. The text of the instant message is stored in the specified variable.</p>
Include Message in Session Log Sent to User	<p>Check this box if you would like the user to see this message in Microsoft Office Communicator when they are connected with the contact.</p>
On Success Go To	<p>A dropdown list of all other actions that have been placed on the workflow page. Contacts are directed to the action after the instant message is received.</p>
On Timeout Go To	<p>A dropdown list of all other actions that have been placed on the workflow page. Contacts are directed to the action if the instant message is not received within the time specified in the 'Timeout' field.</p>
Hide Incoming Links	<p>An optional checkbox that allows you to hide the incoming links for this action. For more information, refer to Hiding Incoming Links on page 38.</p>
Log Action	<p>An optional checkbox that allows you to log information about this action. For more information, refer to Logging Activity for an Action on page 44.</p>

Reply Instant Message

Compose Reply allows you to send an instant reply to any instant message that has arrived at your contact center. For example, a reply can inform the sender that the message has been received and provide a list of menu options that the sender can choose from. Using additional actions, the workflow can then process the sender's response and route the instant message accordingly.

The table below describes the fields and buttons found on the properties dialog box for Reply Instant Message.

Reply Instant Message	
Option	Description
Action Name	By default, this field shows 'Reply Instant Message.' You can change this by clearing the field and typing a more descriptive name.

Reply Instant Message	
Option	Description
Set Default	A button used to set the default action name. For this action, the default name is 'Reply Instant Message.'
Message	Enter the text that you want to be included in the instant message. You can insert a variable into the message by selecting a variable from the dropdown list and clicking <i>Insert</i> . The value of the variable is included in the instant message that is sent.
Variable	A dropdown list showing system variables and data variables.
Insert	A button used to insert the selected variable into the reply message. You may insert any number of variables into a message.
Include Message in Session Log Sent to User	Check this box if you would like the user to see this message in Microsoft Lync when they are connected with the contact.
Go To	A dropdown list of all other actions that have been placed on the workflow page. Contacts are directed to the action after the reply message is sent.
Hide Incoming Links	An optional checkbox that allows you to hide the incoming links for this action. For more information, refer to Hiding Incoming Links on page 38.
Log Action	An optional checkbox that allows you to log information about this action. For more information, refer to Logging Activity for an Action on page 44.

Wait for Instant Message

Wait for Instant Message is typically the starting point for workflow designed for instant messages. This action gathers information about the message sender, which is stored in system variables. This information includes the IM address to which the message is sent, the IM address of the sender, and much more. For more information on system variables, refer to page 15.

The table below describes the fields and buttons found on the properties dialog box for Wait for Instant Message:

Wait for Instant Message	
Option	Description
Action Name	By default, this field shows 'Wait for Instant Message.' You can change this by clearing the field and typing a more descriptive name.
Set Default	A button used to set the default action name. For this action, the default name is 'Wait for Instant Message.'
Assign to Object	A dropdown list of object variables you have already created. You can create a new variable by typing the name of the variable directly into the field or by selecting '<NEW VARIABLE>' from the list.
Go To	A dropdown list of all other actions that have been placed on the workflow page. All contacts are directed to the action you select from this list.

Wait for Instant Message	
Option	Description
Link Name	Optional fields that allow you to label the links that appear between this action and the actions selected from the 'Go To' dropdown lists.
Hide Incoming Links	An optional checkbox that allows you to hide the incoming links for this action. For more information, refer to Hiding Incoming Links on page 38.
Log Action	An optional checkbox that allows you to log information about this action. For more information, refer to Logging Activity for an Action on page 44.



Chapter 11: Voice I/O Actions

Each workflow action has a distinct set of properties that you must complete when designing workflow. When an action's properties are incomplete, the icon appears on the workflow page with a red background. Any changes that you have made in iceAdministrator cannot be saved until all properties are completed.





Voice I/O (Input/Output) encompasses both text-to-speech and speech recognition. This chapter dedicates one section to text-to-speech, and another to speech recognition. Within the sections, each Voice I/O action is described, including the input fields, buttons, checkboxes, and radio buttons. Use this chapter as a reference for completing required and optional fields for each Voice I/O action type. You may also wish to use this chapter as a reference when modifying Voice I/O actions. Refer to the Voice I/O Workflow Actions table below for a brief description of each Voice I/O action and for a page reference to the appropriate section within this chapter.

This chapter assumes that you are familiar with viewing workflow and that you have created a workflow page and placed the required actions on the workflow page. For information on the tasks associated with creating a workflow page and adding actions, refer to Chapter 1: Introduction to Workflow.

Caution: It is highly recommended to modify workflow outside of regular hours or peak hours. Place a test call to your contact center after changes are saved to ensure that workflow is functioning properly.

Voice I/O Actions Defined

Voice I/O actions are premium actions specifically designed to handle speech recognition and text-to-speech for your contact center, as described in the table below:

Voice I/O Workflow Actions			
Action	Description	Icon	Page
Speak	The only action required for text-to-speech. Text that you specify is spoken back to callers.		402
Allocate Speech Recognition Resource	Ensures that a caller can use speech recognition for the entire duration of the call, or until workflow removes the Resource.		412
Free Speech Recognition Resource	Removes the speech recognition resource from the contact.		414
Get Speech Recognition Results	Retrieves the results of the speech recognition.		416
Start Speech Recognition	Begins the speech recognition.		418

Text-to-Speech

ice's text-to-speech feature uses the Microsoft speech engine. It conforms to the SSML standard. The supported markup we can use is available here: [http://msdn.microsoft.com/en-us/library/hh378377\(v=office.14\).aspx](http://msdn.microsoft.com/en-us/library/hh378377(v=office.14).aspx).

For example: use "`<say-as type="spell"><@g_callerinput></say-as>`" to play back individual alpha numeric characters.

The standard speech output rate is fast. To adjust the speed, use the `<prosody>` tag.

For example, `<prosody rate = 'x-slow'><say-as type="spell"><@g_callerinput></say-as></prosody>`

Note:

- 'x-slow': extra slow.
- The rate can be 'slow,' 'medium,' 'fast,' or 'x-fast.'
- The rate can also be a percentage relative to the default speed – i.e., `<prosody rate = '42'>` will generate a speed output rate that is 42% slower than the default speed.

In the workflow, the Speak action is required to configure text-to-speech in the workflow. The sections that follow explain the Speak action and commonly used voices.

Speak

30: Speak

Action Name:

Language:

Enable DTMF Abort Clear Digit Buffer

Text

File

Full Path on ICE Server:

Enable Playback Controls

Skip/Pause/Resume

Skip Period (ms):

DTMF Keys

Skip Backward:

Pause/Resume:

Skip Forward:

Play To

Caller Callee

On Speak Success Go To Link Name

On Speak Failure Go To Link Name

Hide Incoming Links Log Action

ice provides text-to-speech capabilities through integration with a third-party text-to-speech server. Using the text-to-speech server, the Speak action converts text to speech and plays this information to a caller.

You can type the text to be spoken into the action's text box, or you can specify a file that the Speak action should read.

The table below describes the fields and buttons found on the properties dialog box for Speak:

Speak	
Option	Description
Action Name	By default, this field shows 'Speak.' You can change this by clearing the field and typing a more descriptive name.
Set Default	A button used to generate a new action name based on the properties selected for the action. For this action, the default name is determined by the text to speak. The action name is updated when <i>Set Default</i> is clicked (e.g., 'Speak - Please enter your PIN Number').
Language	The languages that you can use for text-to-speech messages are listed in this drop-down box.
Enable DTMF Abort	Enable this feature if you want to allow callers to "key through" the speech by entering any DTMF (Dual Tone Multi-Frequency) on their touch-tone telephone. If this feature is disabled, the caller must listen to the speech.
Clear Digit Buffer	Enable this feature to clear any digits that might have been entered in a previous action.
Text	Enter the text that you want to be converted to speech. You can insert a variable into the text by selecting a variable from the dropdown list and clicking <i>Insert</i> . The value of the variable is converted to speech. In order to use a variable in the Speak Action's Language field, the value of the variable must correspond to the numeric value of the language pack. For example, if you want to specify the French Canadian TTS language, (aka "French (Canada) (fr-CA 3084)"), then the variable must contain "3084".

Speak	
Option	Description
File	Specify a file that contains the text that you would like to be converted to speech. The file must be located on the ice server, and you must specify the full path.
Enable Playback Controls	Enable this checkbox if you want to allow users to control the playback of the speech. You can let them pause the message, adjust its volume, as well as skip forward and back through it.
Skip/Pause/Resume	Allows users to adjust their playback position in the speech. By default, the playback skips forward or backward by 5000ms each time users press the specified DTMF keys, but you can use the scrolling list to select a different skip period. You can select the keys for position control from the 'Skip Backward,' 'Pause/Resume,' and 'Skip Forward' dropdown lists as necessary. The default for each of these fields is 'NONE' (no user adjustment).
Go To	A dropdown list of all other actions that have been placed on the workflow page. Contacts are directed to the action you select from the list when the speech is complete or if the caller enters DTMF (if 'Enable DTMF Abort' is enabled).
On Play Failure Go To	A dropdown list of all other actions that have been placed on the workflow page. Contacts are directed to the action you select from the list when no resources are available.
Link Name	Optional fields that allow you to label the links that appear between this action and the actions selected from the 'Go To' dropdown lists.
Hide Incoming Links	An optional checkbox that allows you to hide the incoming links for this action. For more information, refer to Hiding Incoming Links on page 38.

Speak	
Option	Description
Log Action	An optional checkbox that allows you to log information about this action. For more information, refer to Logging Activity for an Action on page 44.

Text-to-Speech Voices

There are several voices that can be used in the Speak action. Each voice that you use must already be configured on the ice system and assigned a group ID. The following is a list of available voices when using Microsoft's built-in Text-to-Speech voices.

- English (United States) (en-US 1033)
- English (Canada) (en-CA 4105)
- French (Canada) (fr-CA 3084)
- English (United Kingdom) (en-GB 2057)
- Spanish (Mexico) (es-MX 2058)
- Catalan (Catalan) (ca-ES 1027)
- Danish (Denmark) (da-DK 1030)
- German (Germany) (de-DE 1031)
- English (Australia) (en-AU 3081)
- English (India) (en-IN 16393)
- Spanish (Spain) (es-ES 3082)
- Finnish (Finland) (fi-FI 1035)
- French (France) (fr-FR 1036)
- Italian (Italy) (it-IT 1040)
- Norwegian, Bokmål (Norway) (nb-NO 1044)
- Dutch (Netherlands) (nl-NL 1043)
- Polish (Poland) (pl-PL 1045)
- Portuguese (Brazil) (pt-BR 1046)
- Portuguese (Portugal) (pt-PT 2070)
- Swedish (Sweden) (sv-SE 1053)

Note: Languages that require Unicode support in ice are not fully supported in this release.

Speech Recognition

ice's speech recognition feature is built on Microsoft's speech recognition engine. In the workflow, there are several actions that can be used to create speech recognition workflow. Before these actions can be used, the ice server must be configured by a trained technician.

The sections that follow offer recommendations for application design explain the properties of speech recognition actions, explain the format of the results string, and provide information on call logging.

DTMF-Centric Applications

If you want to provide callers with the option of speaking or using DTMF (i.e., touch tone), you can run the Start Speech Recognition action and the Get Caller Input action simultaneously.

When building this type of speech recognition application, note the following rules and guidelines:

- If DTMF is entered at any time, speech recognition is aborted, and the application behaves as though there is no speech recognition.
- If a DTMF timeout (i.e., First Digit Timeout) occurs, speech recognition is aborted, and the timeout retry logic of the Get Caller Input action is used or the Timeout link is followed, depending on the configuration of Get Caller Input.
- If speech is detected before or during the Get Caller Input action, then any activities (i.e., playing of a Prompt Message) are stopped, and the Failure link of Get Caller Input is followed. When this occurs, the result variable for Get Caller Input contains 4104 as the value. A Get Speech Recognition Results action will also follow the Failure link, and the result variable contains 4329478 as the value.

To disallow barge-in (i.e., the caller cannot key in their selection or speak before the prompt is complete), organize the actions in the following way:

- Play prompts to callers using the Play Audio File action.
- Begin speech recognition using the Start Speech Recognition action.
- Configure the Get Caller Input action without 'No Message' selected for the First Message and 'No Message' selected for the Prompt Message.

Speech Recognition-Centric Applications

Speech Recognition-centric applications assume that most callers will not use DTMF. Therefore, unlike the application design for DTMF-centric applications, the Start Speech Recognition and Get Caller Input actions do not run at the same time.

When building this type of speech recognition application, note the following rules and guidelines:

- If DTMF is entered at any time, speech recognition is aborted, and the Failure link is followed on the Get Speech Recognition Result action. When this occurs, the result variable for Get Speech Recognition Result contains 4100 as the value. Get Caller Input can be configured with 'Clear Digit Buffer' disabled to retrieve the digits entered by the caller.
- Get Speech Recognition blocks (i.e., the caller does not continue in the workflow) until a result is returned, a recognition timer expires, or DTMF is entered. Set appropriate timer values in the Start Speech Recognition action to ensure that a caller does not wait in the Get Speech Recognition action indefinitely.

To disallow barge-in (i.e., the caller cannot speak before the prompt is complete), organize the actions in the following way:

- Play prompts to the caller using the Play Audio File action.
- Begin speech recognition using the Start Speech Recognition action.
- Retrieve results using the Get Speech Recognition Results action.
- Go to Get Caller Input, if required.

The example below shows how a Speech Recognition-centric application can be structured:

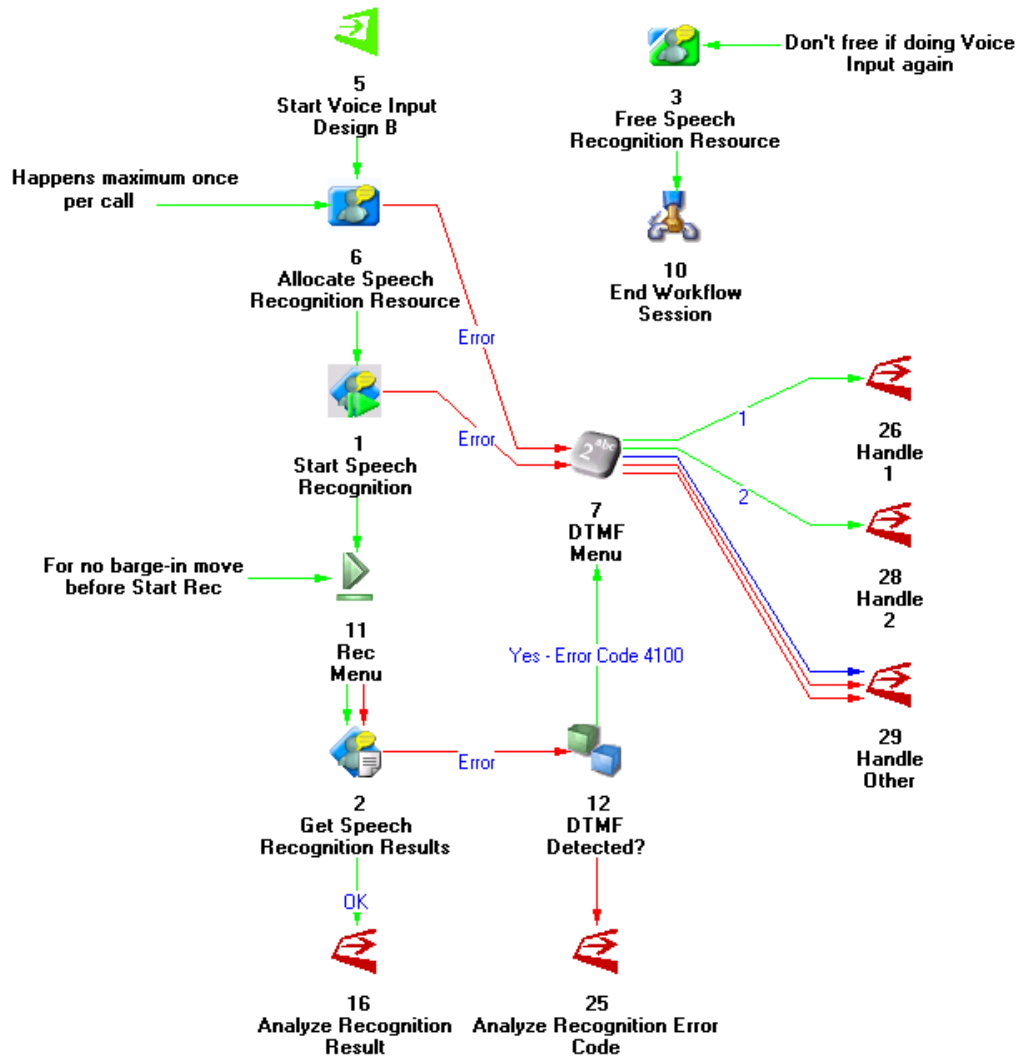

Allocate Speech Recognition Resource

Allocate Speech Recognition Resource is used to ensure that a caller can use speech recognition for the entire duration of the call, or until workflow removes the resource.

Note: A Speech Recognition Resource can be assigned to a caller only once within the workflow. For example, the workflow cannot assign a resource, free the resource, and then re-assign a resource to the same caller. If speech recognition is required at the beginning of the call and then again at the end of the call, the resource must stay assigned to the contact for the duration of the call.

The table below describes the fields and buttons found on the properties dialog box for Allocate Speech Recognition Resource:

Allocate Speech Recognition Resource	
Option	Description
Action Name	By default, this field shows 'Allocate Speech Recognition Resource.' You can change this by clearing the field and typing a more descriptive name.
Set Default	A button used to generate a new action name based on the properties selected for the action. For this action, the default name is determined by the configuration file. The action name is updated when <i>Set Default</i> is clicked (e.g., 'Allocate Speech Rec Resource - @ConfigFile').

Allocate Speech Recognition Resource	
Option	Description
Configuration File	Enter the configuration file for the speech recognition client. This file is typically d:\ice\config\nce-config.cfg. The configuration file specifies the location of the grammar file and recognition server.
On Success Go To	A dropdown list of all other actions that have been placed on the workflow page. Contacts are directed to the action you select from this list.
On Failure Go To	A dropdown list of all other actions that have been placed on the workflow page. Contacts are directed to the action when no Speech Recognition Resource can be allocated (which can occur if all licensed ports are in use) or if the speech recognition server is down. In either case, the result code will be set to 4329475 in \$System:ResultCode.
Link Name	Optional fields that allow you to label the links that appear between this action and the actions selected from the 'Go To' dropdown lists.
Hide Incoming Links	An optional checkbox that allows you to hide the incoming links for this action. For more information, refer to Hiding Incoming Links on page 38.
Log Action	An optional checkbox that allows you to log information about this action. For more information, refer to Logging Activity for an Action on page 44.

Free Speech Recognition Resource

Free Speech Recognition Resource is used to remove a Recognition Resource from the contact. The Resource is then available for use by other contacts.

Note:

- A Speech Recognition Resource can be assigned to a caller only once within the workflow. For example, the workflow cannot assign a resource, free the resource, and then assign a resource to the same caller. If speech recognition is required at the beginning of the call and then again at the end of the call, the resource must stay assigned to the contact for the duration of the call.
- The following actions will automatically free a Recognition Resource (i.e., without using Free Speech Recognition Resource): Route Object, Play Music on Hold (only when 'Play Music from Broadcaster' is enabled), and End Workflow. The Recognition Resource will also be freed if a user answers the call, or if the caller hangs up.

The table below describes the fields and buttons found on the properties dialog box for Free Speech Recognition Resource:

Free Speech Recognition Resource	
Option	Description
Action Name	By default, this field shows 'Free Speech Recognition Resource.' You can change this by clearing the field and typing a more descriptive name.
Set Default	A button used to set the default action name. For this action, the default name is 'Free Speech Recognition Resource.'

Free Speech Recognition Resource	
Option	Description
Go To	A dropdown list of all other actions that have been placed on the workflow page. Contacts are directed to the action you select from this list.
Link Name	An optional field allowing you to label the link that appears between this action and the action selected from the 'Go To' dropdown list.
Hide Incoming Links	An optional checkbox that allows you to hide the incoming links for this action. For more information, refer to Hiding Incoming Links on page 38.
Log Action	An optional checkbox that allows you to log information about this action. For more information, refer to Logging Activity for an Action on page 44.

Get Speech Recognition Result

Get Speech Recognition Results can be used once a caller has been prompted to speak. The action waits for the speech to complete and then returns the recognition results. If the action is used later in the workflow (e.g., after the speech recognition is complete), it retrieves the last recognition results, provided they are available.

The table below describes the fields and buttons found on the properties dialog box for Get Speech Recognition Results:

Get Speech Recognition Results	
Option	Description
Action Name	By default, this field shows 'Get Speech Recognition Results.' You can change this by clearing the field and typing a more descriptive name.
Set Default	A button used to generate a new action name based on the properties selected for the action. For this action, the default name is determined by the variable used to store recognition results. The action name is updated when <i>Set Default</i> is clicked (e.g., 'Get Speech Rec Results - @SpeechRecResults').

Get Speech Recognition Results	
Option	Description
Store Recognition Results in Variable	A dropdown list of existing data variables. You can create a new variable by typing the name of the variable directly into the field or by selecting '<NEW VARIABLE>' from the list. The recognition results are stored in the specified variable. The format of the result depends on the options selected in the Start Speech Recognition action. For more information, refer to page 422.
Go To	A dropdown list of all other actions that have been placed on the workflow page. Contacts are directed to the action you select from this list when the results are returned.
On Error Go To	A dropdown list of all other actions that have been placed on the workflow page. Contacts are directed to the action you select from this list when there are no results returned.
Link Name	Optional fields that allow you to label the links that appear between this action and the actions selected from the 'Go To' dropdown lists.
Hide Incoming Links	An optional checkbox that allows you to hide the incoming links for this action. For more information, refer to Hiding Incoming Links on page 38.
Log Action	An optional checkbox that allows you to log information about this action. For more information, refer to Logging Activity for an Action on page 44.

Start Speech Recognition

The table below describes the fields and buttons found on the properties dialog box for Start Speech Recognition:

Start Speech Recognition	
Option	Description
Action Name	By default, this field shows 'Start Speech Recognition.' You can change this by clearing the field and typing a more descriptive name.
Set Default	A button used to generate a new action name based on the properties selected for the action. For this action, the default name is determined by the grammar file. The action name is updated when <i>Set Default</i> is clicked (e.g., 'Start Speech Rec - @GrammarFile').

Grammar	<p>This drop-down shows the name of the grammar file (e.g., .yesno).</p> <p>The location of the grammar file is specified in the configuration file (the Allocate Speech Recognition Resource action allows you to enter the location of the configuration file). You can type in the name of the file, select a variable from the dropdown list, or create a new variable by selecting '<NEW VARIABLE>' from the list.</p> <p>Note: Start Speech Recognition can be used to stop active recognition if the grammar field is left blank.</p> <p><u>The grammar field accepts:</u></p> <ul style="list-style-type: none">Non-compiled .GRXML file and pathCompiled .cfg grammar fileXML string representing a valid GRXML grammar to compile <p><u>Compiled .cfg grammar file:</u></p> <p>Once compiled and/or read from disk, the compiled grammar is then cached in the allocated speech engine, until the end of the call, Dealloc is called or Alloc is called again.</p> <p><u>Pre-compiled or un-compiled grammar file:</u></p> <p>The file name must be in this format: <rootname>,<grammarFilename>.</p> <p>For example: yesno,en-US.cfg</p> <p><u>XML grammar:</u></p> <p>Root name must be specified in the GRXML header.</p> <p>For example:</p> <pre><grammar xml:lang="en-US" version="1.0" xmlns="http://www.w3.org/2001/06/grammar" tag-</pre>
----------------	---

Start Speech Recognition	
Option	Description
	format="semantics/1.0" root="fruit"> <rule id="fruit" scope="public">
Results Format String	Refer to page 422 for more information.
Min Pre-Speech Silence	The number of seconds required before an utterance is accepted as valid. This timer can be used to determine if the caller started talking before speech recognition was started. The default value is 2000 ms (2 seconds). If the specified duration of silence is not detected, the contact follows the 'On Error Go To' link.
No Speech Timeout	The number of milliseconds that ice waits for an utterance to be spoken. The default value is 32000000 ms (approximately 9 hours). When the timeout is reached, the contact follows the 'On Error Go To' link.
Too Much Speech Timeout	The maximum length of an utterance, in milliseconds. The default value is 60000 ms (60 seconds).
Max N-best Results to Return	The maximum number of results to return. The default value is 3. For example, if the caller says "cat," the application might be 85% confident that caller said "cat," 75% confident the caller said "bat," and 70% confident the caller said "mat." If the value is set to 2, then "cat" and "bat" are returned.
Confidence Threshold	The confidence threshold the utterance must score to be considered a result. If the utterance does not meet the confidence threshold, the contact follows the 'On Error Go To' link.
Go To	A dropdown list of all other actions that have been placed on the workflow page. The contact follows this link when the results are returned Microsoft's speech recognition engine.

Start Speech Recognition	
Option	Description
On Error Go To	Callers are directed here if there is a bad grammar name or bad format string, for example. See the table below for a list of failure codes.
Link Name	Optional fields that allow you to label the link that appears between this action and the action selected from the 'Go To' dropdown lists.
Hide Incoming Links	An optional checkbox that allows you to hide the incoming links for this action. For more information, refer to Hiding Incoming Links on page 38.
Log Action	An optional checkbox that allows you to log information about this action. For more information, refer to Logging Activity for an Action on page 44.

The following result codes are set if the 'On Error Go To' link is followed:

'On Error Go To' Result Codes	
Result Code	Description
4329474	NCE_REASON_ABORTED.
4329475	NCE_REASON_ACCEPTED.
4329476	NCE_REASON_REJECTED.
4329477	NCE_REASON_SPEECH_TO_EARLY.
4329478	NCE_REASON_NO_SPEECH.
4329479	NCE_REASON_TOO_MUCH_SPEECH.
4329480	NCE_REASON_TOO_SLOW.
4329503	NCE_REASON_UNKNOWN_GRAMMAR.
9371910	TS_ERR_NOT_ALLOCATED.
9371973	TS_ERR_NOT_STARTED.

Recognition Results Format String

Start Speech Recognition requires you to specify the 'Results Format String.' The string you specify in this field determines the information returned in the result variable of Get Speech Recognition Result. You can specify the format using the following conventions:

- Each field is delineated by angle brackets ("`<`" and "`>`"). For example, "`<&confidence>;<date>`".
- Specify result-level information first, delineated by curly brackets ("`{`" and "`}`"). Result-level information applies to all hypotheses or interpretations returned in the result (e.g., the length of the result). Results that are unique for each hypothesis, such as `<&answer>` and `<&confidence>`, should not be inside the curly brackets.
- Standard fields are requested using a pre-determined syntax and are preceded by an ampersand ("`&`"). Refer to the tables below for a list of supported fields.
- Slots are referenced by name (e.g., `<date>`). Slot confidence scores are referenced using the following format **%slotname** (e.g., `<%date>`).
- Slot features are referenced using the format **slotname.featurename** (e.g., `<date.month>`).
- Format specification for each field is allowed using the format **- min_width.max_width**. Use the hyphen (`-`) to invoke left justification for fields where the value is shorter than the specified minimum width. Right justification is the default. For example, the specification `<date.month:3.9>` causes the month feature of the date slot to be printed with a minimum of three characters and a maximum of 9 characters, using the right justification.

Note: "`\`" is used as the escape character.

The table below describes the supported result-level fields.

Result-level Fields	
Result Level	Description
&num_answers	The total number of answers returned. This includes a count of all hypotheses returned by N-best processing and of all natural language interpretations for each of the hypotheses.
&utt_length	The length of the utterance.

Result-level Fields	
Result Level	Description
&status	The status, or type, of the result. This is the value returned by the Get Speech Recognition Result, and can be one of the following: EMPTY, REJECTED, SPEECH_TOO_EARLY, NO_SPEECH_TIMEOUT, TOO_MUCH_SPEECH_TIMEOUT, RECOGNIZER_TOO_SLOW_TIMEOUT, RECOGNITION, ENROLLMENT, OR EXCEPTION.
&scale	The scaling factor used to generate the value in the &verify_score field. Currently, this is 1000.

The table below describes the supported answer-level fields.

Answer-level Fields	
Answer Level	Description
&confidence	The confidence score for this hypothesis.
&string	The transcription of the hypothesis.
&num_interps	The number of natural language interpretations produced for this hypothesis.
&num_hyps	The number of hypotheses returned by N-best processing of the utterance.
&hyp_index	The index of this hypothesis with the set of hypotheses.
&interp_index	The index of this interpretation with the set of interpretations returned for the associated hypothesis.

Answer-level Fields	
Answer Level	Description
&new_answer	TRUE if this is the first or only time this interpretation appears within the entire set of answers or FALSE if this interpretation has already been returned. This field is provided because the system does not check whether the same interpretation is returned for different hypotheses.
%slotname	Returns the confidence score of a slot.
slotname	Returns the contents of a slot.
slotname.featurename	Returns the contents of a specific feature within a slot (e.g., an item within a list).

Examples

Consider the following two hypotheses:

- "january twentieth nineteen ninety nine", confidence score=63
- "january twenty fourth nineteen ninety nine", confidence score=52

If the 'Results Format String' in Start Speech recognition is...

```
"<&confidence>;<date.day>;<date.month>;<date.year>;"
```

The value of the result variable in Get Speech Recognition Result will be...

```
"63;20;january;1999;52;24;january;1999;"
```

If the 'Results Format String' in Start Speech recognition is...

```
"{<&num_answers>;<&status>;}<&confidence>;<date.day>;<date.month>;<date.year>;<&num_interps>;"
```

The value of the result variable in Get Speech Recognition Result will be...

```
"2;RECOGNITION;63;20;january;1999;1;52;24;january;1999;1;"
```



Chapter 12: Survey Actions

Each workflow action has a distinct set of properties that you must complete when designing workflow. When an action's properties are incomplete, the icon appears on the workflow page with a red background. Any changes that you have made in iceAdministrator cannot be saved until all properties are completed.



This chapter describes each of the survey workflow actions, including the input fields, buttons, checkboxes and radio buttons. Use this chapter as a reference for completing required and optional fields for each survey action type. You may also wish to use this chapter as a reference when modifying survey actions. Refer to the Survey Actions table for a brief description of each survey action and for a page reference to the appropriate section within this chapter.

This chapter assumes that you are familiar with viewing workflow and that you have created a workflow page and placed the required actions on the workflow page. For information on the tasks associated with creating a workflow page and adding actions, refer to Chapter 1: Introduction to Workflow.

Caution: It is highly recommended to modify workflow outside of regular hours or peak hours. Place test calls or send test emails or IM messages to your contact center after changes are saved to ensure that workflow is functioning properly.

Survey Actions Defined

Survey actions are premium actions specifically designed to handle survey confirmation and participation in your contact center, as described in the table below:

Survey Actions			
Action	Description	Icon	Page
Add or Update Survey	Qualify a survey or update an aspect of qualification for the survey		427
Remove Survey	Remove a survey from the contact in the current interaction. This will prevent the workflow/system from offering any survey again during the current interaction.		431
Set Survey Response State	Set the Survey Response State of a qualified survey participant.		433

Add or Update Survey

23: Add or Update Survey

Action Name:

Survey ID:

Override Probability

Language LCID:

Queue ID:

Override Modality / Update Response Completion Address

Voice

Callback Number:

Callback Delay (s):

Email

Email Address:

Email Group ID:

Go To:

Link Name:

On Failure Go To:

Link Name:

Hide Incoming Links

Log Action

Use the Add or Update Survey action to qualify a contact at various points in the workflow. ice qualifies contacts that enter the system using the Survey Form properties. This action can also be used to update a specific aspect of qualification for the survey.

The table below describes the fields and buttons found on the properties dialog box for Add and Update Survey:

Add or Update Survey	
Option	Description
Action Name	By default, this field shows 'Speak.' You can change this by clearing the field and typing a more descriptive name.
Set Default	<p>A button used to generate a new action name based on the properties selected for the action.</p> <p>For this action, the default name is determined by the text to speak. The action name is updated when <i>Set Default</i> is clicked (e.g., 'Speak - Please enter your PIN Number').</p>
Survey ID	Enter the Survey ID that the contact is qualifying against.
Override Probability	Overrides Presentation Probability field that is set in the survey run form.
Language LCID	Use this field to set the language for this survey as per the language codes used in the DB.
Queue ID	The Queue ID that is associated with the contact will be qualified against the Survey Runs.

Add or Update Survey	
Option	Description
Override Modality	<p>Override the contact modality set for the selected survey in the Survey Form.</p> <p>This option can also be used to update how the survey is presented.</p> <ol style="list-style-type: none"> 1. If a voice contact qualifies for a Survey Run and their email address is available through other means, Override Modality can be used to send the contact an email with a survey link (if the survey has web and voice modalities). 2. If an IM Contact qualifies for a Survey Run and their email address is available through other means, Override Modality can be used to send the contact an email with the web survey link, instead of presenting the link at the end of the chat session.
Voice	<p>Override and configure survey presentation using Voice options.</p> <p>This option is only available if Override Modality is selected.</p>
Callback Number	<p>The phone number the system will dial for a callback survey.</p> <p>This option is only available if Override Modality and Voice are selected.</p>
Callback Delay	<p>The delay time before the system dials out for a callback survey.</p> <p>This option is only available if Override Modality and Voice are selected.</p>

Add or Update Survey	
Option	Description
Email	Override and configure survey presentation using Email options. This option is only available if Override Modality is selected.
Email Address	Email address to send the web survey link to. This option is only available if Override Modality and Email are selected.
Email Group ID	Email Group ID used to send out the web survey link. This option is only available if Override Modality and Email are selected.
Go To	A dropdown list of all other actions that have been placed on the workflow page. Contacts are directed to the action you select from the list when the action is complete.
On Failure Go To	A dropdown list of all other actions that have been placed on the workflow page. Contacts are directed to the action you select from the list when no resources are available.
Link Name	Optional fields that allow you to label the links that appear between this action and the actions selected from the 'Go To' dropdown lists.
Hide Incoming Links	An optional checkbox that allows you to hide the incoming links for this action. For more information, refer to Hiding Incoming Links on page 38.
Log Action	An optional checkbox that allows you to log information about this action. For more information, refer to Logging Activity for an Action on page 44.

Remove Survey

ice qualifies contacts that enter the system using the Survey Form properties. Use the Remove Survey action to remove a qualified a contact from a survey. This will prevent the workflow/system from offering any survey again during the current interaction.

The table below describes the fields and buttons found on the properties dialog box for Remove Survey:

Remove Survey	
Option	Description
Action Name	By default, this field shows 'Speak.' You can change this by clearing the field and typing a more descriptive name.
Survey ID	Enter the ID associated with the survey to remove the qualified contact.
Go To	A dropdown list of all other actions that have been placed on the workflow page. Contacts are directed to the action you select from the list when the speech is complete or if the caller enters DTMF (if 'Enable DTMF Abort' is enabled).
On Failure Go To	A dropdown list of all other actions that have been placed on the workflow page. Contacts are directed to the action you select from the list when no resources are available.

Remove Survey	
Option	Description
Link Name	Optional fields that allow you to label the links that appear between this action and the actions selected from the 'Go To' dropdown lists.
Hide Incoming Links	An optional checkbox that allows you to hide the incoming links for this action. For more information, refer to Hiding Incoming Links on page 38.
Log Action	An optional checkbox that allows you to log information about this action. For more information, refer to Logging Activity for an Action on page 44.

Set Survey Response State

The system updates the Survey Response State of a contact as it progresses through the workflow. Use the Set Survey Response State action to override and set the Survey Response State of a contact.

For more information on the various Survey Response States, please refer

The table below describes the fields and buttons found on the properties dialog box for Set Survey Response State:

Set Survey Response State	
Option	Description
Action Name	By default, this field shows 'Speak.' You can change this by clearing the field and typing a more descriptive name.
Survey Response ID	Enter the Survey Response ID for which you would like to change the state. Note: The following session variable contains the Response ID associated with the contact: <ul style="list-style-type: none"> • <code>\$Session.SurveyResponses</code>

Set Survey Response State	
Option	Description
State	<p>Select a state from the dropdown list to set the Survey Response State for the contact.</p> <p>The following lists the ID and description for each state:</p> <ul style="list-style-type: none"> • Created = 0 (Contact has qualified for a Survey Run) • Presented=1 (Survey has been presented to the user. Email/IM sent, or callback made) • Started=2 (At least one question has been answered, but submission has not been finalized) • Completed=3 (Complete, finalized submission) • Failed=4 (Failed to present the survey.) • Rejected=5 (Contact rejected the survey) • Expired=6 (Web survey link has passed its expiry interval as defined in Survey Run) • MakingCallback=7 (Workflow is attempting to callback the user) • PendingCallback = 8 (Transition state for a response before workflow attempts a callback on it) • Handled = 9 (Set just before contact leaves workflow if the contact had met with an agent) • Unhandled = 10 (Set just before contact leaves workflow if the contact had not met an agent)
Go To	A dropdown list of all other actions that have been placed on the workflow page. Contacts are directed to the action you select from the list when the speech is complete or if the caller enters DTMF (if 'Enable DTMF Abort' is enabled).
On Failure Go To	A dropdown list of all other actions that have been placed on the workflow page. Contacts are directed to the action you select from the list when no resources are available.

Set Survey Response State	
Option	Description
Link Name	Optional fields that allow you to label the links that appear between this action and the actions selected from the 'Go To' dropdown lists.
Hide Incoming Links	An optional checkbox that allows you to hide the incoming links for this action. For more information, refer to Hiding Incoming Links on page 38.
Log Action	An optional checkbox that allows you to log information about this action. For more information, refer to Logging Activity for an Action on page 44.



Appendix A: Network Transfer Mode

Using Set Telephony Parameter and Get Telephony parameter, you can set and retrieve a parameter defined as *ice.networkxfermode*. This value can be set to 0, 1, 2 or 3, and determines if ice uses SIP REFER transfers:

- 0 – Never perform SIP REFER transfer.
- 1 – Perform SIP REFER transfer for user transfers only (this setting applies to blind transfers only).
- 2 – Perform SIP REFER transfer for workflow transfers only. This includes transfers initiated with Route Object, and call forwarding from a user ID (i.e., All Calls, No Answer, No Login, PAQ Overflow).
- 3 – Perform SIP REFER transfer for all transfers (i.e., 1 and 2).

Using SIP REFER transfer can be useful in a contact center that initiates a high number of transfers. Without SIP REFER transfer, each time a call is transferred, two lines are occupied on ice for the duration of the call; where one line is used to receive the call on ice, and another is used to transfer the caller to the third party. SIP REFER transfer eliminates the need to occupy two trunks.

SIP REFER Transfer

When you use the *ice.networkxfermode* parameter to transfer a SIP call if the transfer fails, ice is notified and resumes control of the call (i.e., The 'On Failure Go To' link of the Route Object action is followed.) The SIP REFER transfer is only used for blind transfers.



Appendix B: Result Codes

Result Codes outlines the error and success messages that appear. Error codes are grouped into General initialization errors, Invalid object pointers, System initialization errors, Serious errors, Warning events, Informational events, Telephony Manager result codes, Switch Manager, and IEV Codes.

General initialization errors	Code	Meaning
IEV_CREATE_OBJECT_ERROR	0x04030001	Cannot create object (object pointer is NULL from operator new)
IEV_INIT_OBJECT_ERROR	0x04030002	Failed in object constructor
IEV_OPEN_DATASOURCE_ERROR	0x04030003	Failed to open DataSource object
IEV_OPEN_SESSION_ERROR	0x04030004	Failed to open database session
IEV_INIT_CRITICALSECTION_ERROR	0x04030005	Failed to initialize critical section
IEV_INVALID_CONNECTID	0x04030006	Invalid ConnectID passed to CWfDataConnectMgr in an attempt to attach to an opened database connection
IEV_CREATE_EVENTMGR_ERROR	0x04030007	Failed to create Event Manager COM object
IEV_QUERY_INTERFACE_ERROR	0x04030008	Failed to query interface on COM object
IEV_CREATE_IMR_ERROR	0x04030009	Failed to create IMR COM object
IEV_ADVISE_SERVER_ERROR	0x0403000A	Failed to advise COM server

General initialization errors	Code	Meaning
IEV_UNADVISE_SERVER_ERROR	0x0403000B	Failed to unadvise COM server
IEV_OLEDB_PROVIDER_ERROR	0x0403000C	OLEDB Provider Error
Invalid object pointers	Code	Meaning
IEV_INVALID_SWITCH_OBJECT	0x04030010	Invalid pointer to OLE DB Switch object
IEV_INVALID_QUEUE_OBJECT	0x04030011	Invalid pointer to OLE DB dboACDQueue object
IEV_INVALID_USER_OBJECT	0x04030012	Invalid pointer to OLE DB dboUser object
IEV_INVALID_USERASSIGNMENT_OBJECT	0x04030013	Invalid pointer to OLE DB dboUserAssignment object
IEV_INVALID_SKILL_OBJECT	0x04030014	Invalid pointer to OLE DB dboSkill object
IEV_INVALID_REQUIREDSKILL_OBJECT	0x04030015	Invalid pointer to OLE DB dboRequiredSkill object
IEV_INVALID_USERSKILL_OBJECT	0x04030016	Invalid pointer to OLE DB dboUserSkill object
IEV_INVALID_WFGRAPH_OBJECT	0x04030017	Invalid pointer to OLE DB dboWfGraph object
IEV_INVALID_WFACTION_OBJECT	0x04030018	Invalid pointer to OLE DB dboWfAction object
IEV_INVALID_WFATTRIBDETAIL_OBJECT	0x04030019	Invalid pointer to OLE DB dboWfAttributeDetail object
IEV_INVALID_WFLINK_OBJECT	0x0403001A	Invalid pointer to OLE DB dboWfLink object
IEV_INVALID_WFLINKDETAIL_OBJECT	0x0403001B	Invalid pointer to OLE DB dboWfLinkDetail object
IEV_INVALID_TRUNKGROUP_OBJECT	0x0403001C	Invalid pointer to OLE DB dboTrunkGroup object

General initialization errors	Code	Meaning
IEV_INVALID_TRUNK_OBJECT	0x0403001D	Invalid pointer to OLE DB dboTrunk object
IEV_INVALID_DNISGROUP_OBJECT	0x0403001E	Invalid pointer to OLE DB dboDnisGroup object
IEV_INVALID_DNIS_OBJECT	0x0403001F	Invalid pointer to OLE DB dboDnis object
IEV_INVALID_HOLIDAY_OBJECT	0x04030020	Invalid pointer to OLE DB dboHoliday object
IEV_INVALID_EMAILGROUP_OBJECT	0x04030021	Invalid pointer to OLE DB dboEmailGroup object
IEV_INVALID_EMAIL_OBJECT	0x04030022	Invalid pointer to OLE DB dboEmail object
IEV_INVALID_CONFIGVALUE_OBJECT	0x04030023	Invalid pointer to OLE DB dboConfigValue object
IEV_INVALID_TEAM_OBJECT	0x04030024	Invalid pointer to OLE DB dboTeam object
IEV_INVALID_TEAMASSIGNMENT_OBJECT	0x04030025	Invalid pointer to OLE DB dboTeamAssignment object

System initialization errors	Code	Meaning
IEV_READ_TABLE_ERROR	0x04030030	Failed to read command rowset
IEV_ADD_SWITCHES_ERROR	0x04030031	Failed to add switches
IEV_ADD_QUEUES_ERROR	0x04030032	Failed to add ACD queues to ACD Manager
IEV_ADD_USERS_ERROR	0x04030033	Failed to add Users to ACD Manager
IEV_ADD_SKILLS_ERROR	0x04030034	Failed to add skills to switch

System initialization errors	Code	Meaning
IEV_ADD_CONTACTGROUPS_ERROR	0x04030035	Failed to add contact groups to switch
IEV_ADD_DNISGROUPS_ERROR	0x04030036	Failed to add DNIS groups to switch
IEV_ADD_DNIS_ERROR	0x04030037	Failed to add DNIS to DNIS group
IEV_ADD_HOLIDAYS_ERROR	0x04030038	Failed to add holidays list
IEV_ADD_REQUIREDSKILLS_ERROR	0x04030039	Failed to add required skills to ACD queue
IEV_ADD_WFENGINES_ERROR	0x0403003A	Failed to add Workflow Engines to Workflow Manager
IEV_ADD_WFACTIONS_ERROR	0x0403003B	Failed to add Workflow Actions to Workflow Engine
IEV_ADD_WFACTION_ATTRIBUTE_ERROR	0x0403003C	Failed to add Workflow Action attribute
IEV_UPDATE_WFACTION_ERROR	0x0403003D	Failed to retrieve attributes and links for action object
IEV_INVALID_FIELDNAME	0x0403003E	Invalid field name
IEV_EMPTY_FIELDVALUE	0x0403003F	Empty field value
IEV_INVALID_FIELDVALUE	0x04030040	Invalid field value
IEV_INVALID_WFATTRIBUTEID	0x04030041	Invalid attribute ID
IEV_INVALID_WFID	0x04030042	Invalid Workflow ID for workflow graph
IEV_INVALID_WFNODEID	0x04030043	Invalid Workflow Node ID
IEV_INVALID_WFLINKID	0x04030044	Invalid Workflow Link ID
IEV_DUPLICATE_WFLINKID	0x04030045	Duplicate Workflow Link ID
IEV_CREATE_CONTACT_ERROR	0x04030046	Failed to create contact record for new interaction
IEV_INVALID_WFENGINE_POINTER	0x04030047	Unable to obtain pointer to Workflow Engine

System initialization errors	Code	Meaning
IEV_INVALID_SESSION_POINTER	0x04030048	Invalid pointer to session (CWfSession) object
IEV_INVALID_EVENT_MGR_POINTER	0x04030049	Invalid pointer to Event Manager
IEV_ADD_CONFIGVALUES_ERROR	0x0403004A	Failed to add config values list
IEV_INVALID_COM_CLASS_POINTER	0x0403004B	Invalid pointer to singleton CWfmEvt COM Class
IEV_ADD_TEAMS_ERROR	0x0403004C	Failed to add teams to ACD Manager
IEV_ADD_TEAM_ASSIGNMENTS_ERROR	0x0403004D	Failed to add teams assignments to team

Serious Errors	Code	Meaning
IEV_INVALID_SWITCHID	0x03030000	Invalid Switch ID
IEV_INVALID_QUEUEID	0x03030001	Invalid Queue ID
IEV_INVALID_WFENGINEID	0x03030002	Invalid Workflow Engine ID (WfEngine ID)
IEV_CANNOT_DELETE_CURRENT_WFENGINE	0x03030003	unable to delete Workflow Engine because it is currently active
IEV_UNKNOWN_EXCEPTION_ON_ACTION	0x03030004	Exception encountered from running workflow action
IEV_SE_EXCEPTION_ON_ACTION	0x03030005	SE-exception encountered from running workflow action
IEV_NO_DEFAULT_LINK	0x03030006	No default or "No Match" link specified
IEV_UNKNOWN_EXCEPTION	0x03033007	Unknown exception
IEV_OPEN_REGISTRY_KEY_ERROR	0x03033008	Failed to open registry key

Serious Errors	Code	Meaning
IEV_CLOSE_REGISTRY_KEY_ERROR	0x03033009	Failed to close registry key
IEV_READ_REGISTRY_KEY_VALUE_ERROR	0x0303300A	Failed to read registry key value
IEV_SET_REGISTRY_KEY_VALUE_ERROR	0x0303300B	Failed to set registry key value
IEV_NO_DEFAULT_REGISTRY_KEY_VALUE	0x0303300C	No default value defined for the registry key
IEV_WRONG_REGISTRY_KEY_VALUE_TYPE	0x0303300D	Unknown register key value type
IEV_INVALID_SKILLID	0x0303000E	Invalid skill ID
IEV_INVALID_DNISGROUPID	0x0303000F	Invalid DNIS group ID
IEV_UNUSABLE_STATS_RESET_TIME	0x03030010	Stats reset time from database is unusable
IEV_INVALID_EXPRESSION_TYPE	0x03030011	Invalid expression type
IEV_ERROR_CREATING_PROCESS	0x03030012	Error creating a process during execute action
IEV_ERROR_WAITING_FOR_OBJECT	0x03030013	Error waiting for a process to end during execute the action
IEV_ERROR_GETTING_EXITCODE	0x03030014	Error getting process exit code during execute action
IEV_ERROR_LOADING_LIBRARY	0x03030015	Error executing LoadLibrary Win32 API
IEV_ERROR_GETTING_PROC_ADDRESS	0x03030016	Error executing GetProcAddress Win32 API
IEV_INVALID_TEAMID	0x03030017	Invalid Team ID

Warning Events	Code	Meaning
IEV_INVALID_ACTION_RULE	0x02030001	Invalid action rule - rule ignored
IEV_UPDATE_REGISTER_ERROR	0x02030010	Unable to update register
IEV_CYCLES_IN_REGISTER_DATA	0x02030011	Cycles detected in register data
IEV_INVALID_REGISTER_NAME	0x02030012	Invalid register name
IEV_UNKNOWN_REGISTER_NAME	0x02030013	Unknown register name
IEV_INVALID_REGISTER_TYPE	0x02030014	Invalid register type
IEV_GET_REGISTER_DATA_ERROR	0x02030015	Failed to read register value
IEV_INSUFFICIENT_BUFSIZE	0x02030020	Insufficient buffer to store returned action structure
IEV_INVALID_REACTIONSIZE_POINTER	0x02030021	Invalid pointer to returned action buffer size
IEV_INVALID_REACTIONBUF_POINTER	0x02030022	Invalid pointer to returned action buffer
IEV_INVALID_EVENT	0x02030023	Invalid event code passed to Workflow Action object
IEV_INVALID_EVENT_DATA	0x02030024	Invalid event data passed to Workflow Action object
IEV_INVALID_EVENT_POINTER	0x02030025	Invalid pointer to event data structure
IEV_CYCLES_IN_WORKFLOW	0x02030026	Cycles detected in workflow
IEV_WFID_ALREADY_EXISTS	0x02030027	Occurs when trying to add a workflow that already exists
IEV_INVALID_DNIS	0x02030030	Invalid or empty DNIS
IEV_DNIS_REJECTED	0x02030031	DNIS is rejected based on current call counts and MinChannels requirements

Warning Events	Code	Meaning
IEV_DNIS_MINS_NOT_SATISFIED	0x02030032	MinChannels conditions for other DNISes not satisfied
IEV_DNIS_NOT_FOUND	0x02030033	DNIS not found in switch
IEV_INVALID_ANI	0x02030034	invalid or empty ANI
IEV_CONFIGVALUE_NOT_FOUND	0x02030035	ConfigValue not found in switch
IEV_TRUNK_NOT_FOUND	0x02030036	Trunk Not found
IEV_INVALID_CONTACTID	0x02030040	Invalid contact ID
IEV_INVALID_CONTACTDETAILS_PTR	0x02030041	Invalid pointer to contact details structure
IEV_INVALID_CONTACTGROUPID	0x02030042	Invalid contact group
IEV_INVALID_ADDRID	0x02030043	Invalid address ID or trunk ID
IEV_ORPHAN_CONTACT_RECORD	0x02030044	Contact record not deleted from last session
IEV_DUPLICATE_QUEUE_REGISTERED	0x02030045	ACD queue is already registered for the contact record
IEV_DUPLICATE_CONTACTID_REGISTERED	0x02030046	Contact record is already registered for this ACD queue
IEV_CONTACTID_NOT_FOUND	0x02030047	Contact record not found in this ACD queue
IEV_INVALID_CONTACTRECORD_PTR	0x02030048	Invalid pointer to contact record object
IEV_INVALID_QUEUEDCONTACT_PTR	0x02030049	Invalid pointer to queued contact object
IEV_FIND_AVAILABLE_USER_ERROR	0x0203004A	Error encountered when searching for available User
IEV_INVALID_ORIGINATOR_PTR	0x0203004B	Invalid pointer to originating party structure

Warning Events	Code	Meaning
IEV_INVALID_USER_DATA_LEN	0x0203004C	Invalid user data length
IEV_INSUFFICIENT_USER_DATA_BUFFER_SIZE	0x0203004D	Insufficient user buffer to hold data
IEV_INVALID_CONTACTTYPE	0x0203004E	Invalid contact type
IEV_INVALID_RECONFIG_TYPE	0x0203004F	Invalid reconfig type
IEV_INVALID_RECONFIG_ACTION	0x02030050	Invalid reconfig action
IEV_INVALID_QUEUE_STATS_TYPE	0x02030051	Invalid queue stats type
IEV_CONTACT_ALREADY_HANDLED	0x02030052	Contact is already being handled
IEV_DUPLICATE_SKILL_UPDATED	0x02030055	Skill previously assigned to contact is now updated
IEV_SKILL_NOT_FOUND_FOR_CONTACT	0x02030056	Skill not found for contact
IEV_GET_SKILL_INFO_ERROR	0x02030057	Failed to get information on skill
IEV_GET_CONTACT_REQUIRED_SKILLS_ERROR	0x02030058	Failed to get required skills for contact
IEV_GET_USER_SKILLS_ERROR	0x02030059	Failed to get skills assigned to User
IEV_DUPLICATE_USER_ASSIGNMENT	0x02030060	User is already assigned to the ACD queue
IEV_DUPLICATE_QUEUE_ASSIGNMENT	0x02030061	ACD queue is already in User's assignments
IEV_USER_ASSIGNMENT_NOT_FOUND	0x02030062	User assignment not found in the ACD queue
IEV_INVALID_USERID	0x02030064	Invalid User ID
IEV_INVALID_USER_PTR	0x02030065	Invalid User object pointer

Warning Events	Code	Meaning
IEV_INVALID_USER_ASSIGNMENT_PTR	0x02030066	Invalid User assignment object pointer
IEV_USER_LOGGED_IN_ELSEWHERE	0x02030067	User already logged in elsewhere
IEV_DIFFERENT_USER_ON_SAME_ADDRESS_ID	0x02030068	Different User is on the same address ID
IEV_ACDQUEUE_NOT_EMPTY	0x02030069	ACD Queue still has queued contacts and cannot be deleted
IEV_INVALID_DN_TYPE	0x0203006A	Invalid DN type
IEV_AUTOLOGON_ALREADY_LOGGED_ON	0x0203006B	User is already logged on while attempting to autologon
IEV_CANNOT_FIND_EMERGENCY_CONTACT	0x0203006C	Cannot find emergency contact to respond to emergency request
IEV_TEAM_ASSIGNMENT_NOT_FOUND	0x0203006D	Team assignment not found in the ACD queue
IEV_DUPLICATE_TEAM_ASSIGNMENT	0x0203006E	The user is already assigned to the team
IEV_INVALID_USER_STATE	0x02030070	Invalid User state
IEV_INVALID_USER_ACTION	0x02030071	Invalid User action
IEV_INVALID_USER_DATALEN	0x02030072	Invalid User data length passed
IEV_FIRE_USER_EVENT_ERROR	0x02030073	Failed to fire User event
IEV_SEND_USER_EVENT_ERROR	0x02030074	Failed to send User event
IEV_FIRE_USER_AVAIL_EVENT_ERROR	0x02030075	Failed to fire User available event
IEV_INVALID_ACTION_RESULT_PTR	0x02030076	Invalid User action result pointer

Warning Events	Code	Meaning
IEV_CYCLES_IN_ROUTE	0x02030077	Cycles detected in route
IEV_INVALID_PAQ_POSITION	0x02030080	Failed to add contact record to specified PAQ position
IEV_ICEPHONE_CMD_PROCESSING_ERROR	0x02030081	Failed to process ICEPhone command
IEV_INVALID_TRUNK_ACTION	0x02030090	Invalid trunk action
IEV_INVALID_TRUNK_EVENT	0x02030091	Invalid trunk event
IEV_INVALID_TRUNK_DATALEN	0x02030092	Invalid trunk data length passed
IEV_SEND_RESET_STATS_EVENT_ERROR	0x02030094	Failed to send reset stats event
IEV_SEND_QUEUE_STATS_EVENT_ERROR	0x02030095	Failed to send queue stats event
IEV_SEND_CONTACT_EVENT_ERROR	0x02030096	Failed to send contact event
IEV_FIRE_CONTACT_ACTIVITY_ERROR	0x02030097	Failed to fire contact activity
IEV_INVALID_CONTACT_EVENT	0x02030098	Invalid contact event
IEV_FIRE_CONTACT_GROUP_UPDATE_ERROR	0x02030099	Failed to fire contact group Update
IEV_INVALID_MESSAGE_LENGTH	0x020300A5	Message from IMR is an invalid length
IEV_INVALID_MESSAGE_TYPE	0x020300A6	Message from IMR has an invalid Message Type
IEV_INVALID_MESSAGE_PARM	0x020300A7	Message from IMR has an invalid Message Paramater

Informational Events	Code	Meaning
IEV_PENDING_ACTION	0x01030000	Workflow action has pending action to be executed by calling process
IEV_ROUTE_TO_DIFFERENT_SWITCH	0x01030001	Route contact to a different workflow engine
IEV_ROUTE_TO_DIFFERENT_ENGINE	0x01030002	Route contact to a different switch
IEV_ROUTE_TO_STARTING_ACTION	0x01030003	Proceed to the starting action
IEV_NEW_CONFIG_REGISTRY_KEY_CREATED	0x01030004	New configuration registry key created
IEV_NEW_REGISTRY_KEY_VALUE_ADDED	0x01030005	New configuration registry key value added
IEV_NO_USER_ASSIGNMENTS	0x01030006	User is not assigned to any ACD queues
IEV_INVALID_TRUNK_GROUP_ACCESS_CODE	0x01030007	Trunk group access code not found in trunk groups for the switch
IEV_INVALID_USER_LOGON_PASSWORD	0x01030008	User logon password is invalid
IEV_INVALID_DESTINATION_ADDRESS	0x01030009	Invalid or empty destination address
IEV_DESTINATION_ADDRESS_BUSY	0x0103000A	Called destination busy
IEV_DESTINATION_ADDRESS_NOT_LOGGED_ON	0x0103000B	Called destination not logged on
IEV_REROUTE_CALL	0x0103000C	Reroute call
IEV_INAPPROPRIATE_USER_ACTION	0x0103000D	User action performed in wrong state

Informational Events	Code	Meaning
IEV_INAPPROPRIATE_USER_EVENT	0x0103000E	User event received in wrong state
IEV_INVALID_USER_ADDRESSID	0x0103000F	invalid User Address ID
IEV_INVALID_REMOTE_USER_DN	0x01030010	invalid remote User DN
IEV_USER_ACTION_REFUSED_BY_COS	0x01030011	User does not have the class-of-service to perform action
IEV_NO_SUITABLE_PAQ_CONTACT_FOUND	0x01030012	no suitable contact found in User's PAQ
IEV_CONTACT_NOT_IN_PAQ	0x01030013	given contact not in User's PAQ
IEV_CALLS_IN_PAQ	0x01030014	User's PAQ not empty (logoff denied)
IEV_NOT_AUTHORIZED_TO_MONITOR_TARGET	0x01030015	not authorized to monitor target User
IEV_DEQUEUE_OBJECT_ERROR	0x01030016	failed to dequeue object
IEV_INVALID_GET_INPUT_DATA	0x01030017	invalid received digit(s) or event
IEV_INVALID_WORKFLOW_DN	0x01030018	invalid Workflow DN
IEV_QUEUE_BUSY	0x01030019	Queue is in Busy State
IEV_QUEUE_EMPTY	0x0103001A	Queue is empty
IEV_QUEUE_IN_NIGHT_MODE	0x0103001B	no Users logged into the ACD queue - queue in night mode

The following is a list of possible low-level ResultCodes from the Telephony Manager:

Telephony Manager Result Code	Code
TS_ERR_NOT_FOUND	0x008F0100
TS_ERR_PARAMETER_NULL	0x008F0101
TS_ERR_INVALID_PORT_TYPE	0x008F0102

The following is a list of possible low-level ResultCodes from the Telephony Manager:	
Telephony Manager Result Code	Code
TS_ERR_INVALID_PORT_SUB_TYPE	0x008F0103
TS_ERR_NO_AVAILABLE_RESOURCE	0x008F0104
TS_ERR_INVALID_PARAMETER	0x008F0105
TS_ERR_NOT_ALLOCATED	0x008F0106
TS_ERR_ALREADY_OPEN	0x008F0107
TS_ERR_INVALID_SWITCH_NUM	0x008F0108
TS_ERR_INVALID_CONN_ID	0x008F0109
TS_ERR_NOT_SUPPORTED	0x008F010a
TS_ERR_INVALID_STATE	0x008F010b
TS_ERR_BUFFER_TOO_SMALL	0x008F010c
TS_ERR_STATE_NOT_FOUND	0x008F010d
TS_ERR_SUB_STATE_NOT_FOUND	0x008F010e
TS_ERR_MICRO_STATE_NOT_FOUND	0x008F010f
TS_ERR_OUT_OF_MEMORY	0x008F0110
TS_ERR_TOO_MANY_DIGITS_REQUESTED	0x008F0111
TS_ERR_OP_NOT_SUPPORTED_BY_MEDIA	0x008F0112
TS_ERR_BOARD_PORT_NUM_NOT_DEFINED	0x008F0114
TS_ERR_CALL_ALREADY_CREATED	0x008F0118
TS_ERR_NO_CALL_CREATED	0x008F0119
TS_ERR_RESOURCE_ALREADY_ALLOCATED	0x008F011a
TS_ERR_RESOURCE_NOT_ALLOCATED	0x008F011b
TS_ERR_UNEXPECTED_EVENT	0x008F011c
TS_ERR_DUPLICATE_ENTRY	0x008F011d

The following is a list of possible low-level ResultCodes from the Telephony Manager:	
Telephony Manager Result Code	Code
TS_ERR_ALREADY_CONNECTED	0x008F011e
TS_ERR_NOT_CONNECTED	0x008F011f
TS_ERR_STARTING_EVENTSIM_THREAD	0x008F0120
TS_ERR_BAD_NUMBER	0x008F0121
TS_ERR_INVALID_BROADCASTER_NUM	0x008F0122
TS_ERR_INVALID_TONE_NUM	0x008F0123
TS_ERR_INVALID_FEATURE_KEY	0x008F0124
TS_ERR_INVALID_BOARD_NUM	0x008F0125
TS_ERR_NUMBER_NOT_PRESENT	0x008F0126
TS_ERR_CONTACT_ID_ALREADY_SET	0x008F0127
TS_ERR_MONITOR_ALREADY_ALLOCATED	0x008F0128
TS_ERR_MONTARGET_ALREADY_ALLOCATED	0x008F0129
TS_ERR_GENERATING_TMP_FILENAME	0x008F012a
TS_ERR_NO_FREE_TRUNK	0x008F012b
TS_ERR_INVALID_WORKFLOW_RESULT	0x008F012c
TS_ERR_UNEXPECTED_DATA_BUFFER_SIZE	0x008F012d
TS_ERR_WAIT_DONE_TIMEOUT	0x008F012e
TS_ERR_WF_RETRIES_EXCEEDED	0x008F012f
TS_ERR_CTSRVC_INIT_FAILED	0x008F0130
TS_ERR_CTSRVC_CREATE_FAILED	0x008F0131
TS_ERR_CREATE_STATE_TABLE_FAILED	0x008F0132
TS_ERR_NO_THREAD	0x008F0133
TS_ERR_DUP_HANDLE_FAILED	0x008F0134

The following is a list of possible low-level ResultCodes from the Telephony Manager:	
Telephony Manager Result Code	Code
TS_ERR_GETHANDLE_FAILED	0x008F0135
TS_ERR_CREATE_BROADCASTER_OBJ_FAILED	0x008F0136
TS_ERR_CREATE_EVENT_FAILED	0x008F0137
TS_ERR_CREATE_IH_OBJ_FAILED	0x008F0138
TS_ERR_CREATE_IH_NODE_OBJ_FAILED	0x008F0139
TS_ERR_CREATE_BC_NODE_OBJ_FAILED	0x008F013a
TS_ERR_IH_NOT_RUNNING	0x008F013b
TS_ERR_REGISTRY_READ	0x008F013c
TS_ERR_INVALID_SECURITY_KEY	0x008F013d
TS_ERR_FUNCTION_ACTIVE	0x008F013e
TS_ERR_STARTING_TTSPORTMANAGER_THREAD	0x008F013f
TS_ERR_TTS_NOT_ENABLED	0x008F0140
TS_ERR_INVALID_TTSENGINE_TYPE	0x008F0141
TS_ERR_INVALID_PARM_TYPE	0x008F0142
TS_ERR_INVALID_PARM_FORMAT	0x008F0143
TS_ERR_INVALID_ASRENGINE_TYPE	0x008F0144
TS_ERR_NOT_STARTED	0x008F0145
TS_ERR_ECT_TRANSFER_FAILED	0x008F0146
TS_ERR_FILE_READ_ERROR	0x008F0147
TS_ERR_LOAD_LIBRARY_ERROR	0x008F0148
TS_ERR_GET_PROC_ADDRESS_ERROR	0x008F0149
TS_ERR_BAD_TTS_TEXT	0x008F014a
SWM_ERR_LISTENER_BUSY	0x170001

The following is a list of possible low-level ResultCodes from the Telephony Manager:	
Telephony Manager Result Code	Code
SWM_ERR_CONNECTION_ALREADY_EXISTS	0x170002
SWM_ERR_UNKNOWN_SWITCHTYPE	0x170003
SWM_ERR_CFG_FAILED	0x170004
SWM_ERR_NO_PATH	0x170005
SWM_ERR_NOT_LISTENER	0x170007
SWM_ERR_NOT_TALKER	0x170008
SWM_ERR_COMM_FAILURE	0x17000A
SWM_ERR_INVALID_SWITCH	0x17000B
SWM_ERR_NOT_CONNECTED	0x17000D
SWM_ERR_DISABLED	0x17000F
SWM_ERR_NO_CFG_FILE	0x170010
SWM_ERR_UNKNOWN_ERROR	0x170011
SWM_ERR_BUS_BUSY_OTHER_CONN_TYPE	0x170012
SWM_ERR_INVALID_CLIENT	0x170013
SWM_ERR_PARTIAL_DISCONNECT	0x170014

Switching Manager Error Codes	
General Errors	Code
SWIERR_INVALID_COMMAND	0x40000
SWIERR_DLL_INVALID_DEVICE	0x40001
SWIERR_DEVICE_ERROR	0x40002
SWIERR_NO_RESOURCES	0x40003
Parameter Errors	Code

Switching Manager Error Codes	
General Errors	Code
SWIERR_INVALID_STREAM	0x40004
SWIERR_INVALID_TIMESLOT	0x40005
SWIERR_MISSING_PARAMETER	0x40006
SWIERR_INVALID_CLOCK_PARM	0x40007
SWIERR_INVALID_SPEED	0x40008
SWIERR_NOT_CONFIGURABLE	0x40009
SWIERR_INVALID_MODE	0x4000A
SWIERR_INVALID_MINOR_SWITCH	0x4000B
SWIERR_INVALID_PARAMETER	0x4000C
SWIERR_UNSUPPORTED_MODE	0x4000D
Switch Errors	Code
SWIERR_NO_PATH	0x4000D
SWIERR_SWITCH_VERIFY_ERROR	0x4000F
SWIERR_INTERNAL_CONFLICT	0x40010
SWIERR_CONNECTION_NOT_SUPPORTED	0x40011
SWIERR_MVIP_BUS_NOT_ENABLED	0x40012
Generic Errors	Code
SWIERR_UNKNOWN_ERROR	0x40013
NCC Errors	Code
NCCERR_NOT_CAPABLE	0x001C0001
NCCERR_INVALID_CALL_STATE	0x001C0002
NCCERR_ADDRESS_BLOCKED	0x001C0003
NCCERR_NO_CALLID	0x001C0004
VCE Errors	Code

Switching Manager Error Codes	
General Errors	Code
VCEERR_INVALID_MESSAGE	0x30000
VCEERR_NO_MESSAGE	0x30001
VCEERR_INVALID_OPERATION	0x30002
VCEERR_PLAY_ONLY	0x30003
VCEERR_NO_SPACE	0x30004
VCEERR_MIXED_ENCODING	0x30005
VCEERR_WRONG_FILE_TYPE	0x30006
VCEERR_WRONG_ENCODING	0x30007
VCEERR_OUT_OF_INDICES	0x30008
VCEERR_UNSUPPORTED_ENCODING	0x30009
VCEERR_BAD_PROMPT_COMMAND	0x30000A
VCEERR_PROMPT_BUILD_FAIL	0x30001B
VCEERR_CONVERSION_FAILED	0x30002C

IEV Error	Code	Description
IEV_PASSWORD_ERROR_ACCOUNT_LOCKED	0x01030023	A user account is locked
IEV_PASSWORD_ERROR_PASSWORD_EXPIRED	0x01030024	User password failed
IEV_PASSWORD_ERROR_PASSWORD_LAST_ATT EMP	0x01030025	User password failed, the last attempt before the account is locked.
IEV_PASSWORD_ERROR_RETRY_MAX_REACHED	0x01030026	User retry password has reached max retry
IEV_PASSWORD_ERROR_PASSWORD_ALREADY USED	0x01030027	User password was previously used

IEV Error	Code	Description
IEV_PASSWORD_ERROR_CHANGE_DENIED	0x01030028	User password cannot be changed, due to min change password requirement.
IEV_PASSWORD_ERROR_NOT_ALLOW_TO_LOGIN_FROM_DEVICE	0x01030029	The user cannot log in from the device (i.e., phone set)
IEV_PASSWORD_ERROR_FAILED_PASSWORD_POLICY	0x01030030	User password failed min length policy.
IEV_ROUTINGRULE_MATCH_NOT_FOUND	0x01030031	Failed to find a regular expression routing rule.
IEV_ERR_NO_FREE_TRUNK	0x01030032	Failed to find a free trunk for outbound calls.
IEV_ERR_FAILED_CONNECT_USER_DEVICE	0x01030033	Failed to connect to the User phone device.
IEV_SWITCH_IS_NOT_ACTIVE	0x01030034	The switch is not active error
IEV_FIRE_SWITCH_ACTIVITY_ERROR	0x01030035	Failed to fire switch activity event
IEV_LOGON_ATTEMPT_THRESHOLD_REACHED	0x01030036	Logon attempt was in progress longer than the threshold time



Appendix C: Survey Response State Diagram

The system updates the Survey Response State of a contact as it progresses through the workflow. Use the following diagram to understand the various Survey Response States:

Survey Name	Survey ID	Description
Created	0	Contact has qualified for a Survey Run.
Presented	1	Survey has been presented to the user. Email/IM sent, or callback made.
Started	2	At least one question has been answered, but submission has not been finalized.
Completed	3	Complete, finalized submission.
Failed	4	Failed to present the survey.
Rejected	5	Contact rejected the survey.
Expired	6	Web survey link has passed its expiry interval as defined in Survey Run.
MakingCallback	7	Workflow is attempting to callback the user.
PendingCallback	8	Transition state for a response before workflow attempts a callback on it.
Handled	9	Set just before contact leaves workflow if the contact had met with an agent
Unhandled	10	Set just before contact leaves workflow if the contact had not met an agent

Index

A

actions. *See* workflow actions

adding

- actions to existing workflow, 55
- actions to workflow page, 28
- holidays, 102
- variables, 120
- workflow graphs, 23, 137, 142, 143, 146, 148, 150
- workflow pages, 23, 137, 142, 143, 146, 148, 150

allocate speech recognition resource, 410

ANI, defined, 171

assign DN, 160

assign skills to object, 162

assign value to variable, 166

audio message groups

- adding, 73
- deleting, 95

audio messages

- base subdirectories, 72, 85
- deleting, 93
- deleting all, 97
- viewing, 68

B

base subdirectories, 70, 72, 85

C

call web service, 294

check ANI, 171

check DNIS, 174

check email, 377

comment, 181

compare data, 183

compose reply, 380

connector in, 188

connector out, 190

contact center, defined, xi

contacts, defined, xi

creating

- audio messages, 75, 87
- holidays, 102
- variables, 120
- workflow graphs, 23, 137, 142, 143, 146, 148, 150
- workflow pages, 23, 137, 142, 143, 146, 148, 150

cut and paste workflow, 51

D**datetime**, 117

DB begin transaction, 367

DB close handle, 371

DB connect, 357

DB end transaction, 369

DB execute query, 360

DB next record, 364

deleting

audio messages, 93

holidays, 103

variables, 127

workflow actions, 58

workflow graphs, 61, 151, 152

dial digits, 192

E

email messages, workflow for, 19, 21

end workflow session, 225

evaluate expression, 194

execute external action, 308, 311

exit building block routine, 320

F

free speech recognition resource, 412

G

get caller input, 213

get object user data, 303

get queue status, 220

get speech recognition result, 414

get telephony parameter, 305

H

hiding incoming links, 38

holidays

adding, 102

check time schedule, 178

deleting, 103

deleting all, 104

viewing, 100

Iice³, defined, xi

iceManager Administrator, defined, xi

L

link router

in use, 40

properties, 226

links

moving, 53

viewing, 13

logging activity for an action, 44

M

make call, 321

messages

adding, 75, 87

deleting, 93

viewing, 68

N

network transfer mode, 434

O

obtain lock action, 329

origin contact groups, 32

output debug string, 331

P

play audio file, 227

play music on hold, 231

Q

queue object, 234

R

receive instant message, 392

record audio file, 238

reject call, 244

release link transfer (RLT), 434

release lock action, 333

remove object from queue, 247

remove skills, 249

reply instant message, 394

Result Code, 435

route object, 251

routine

 routine properties. *See* routine properties

routines

 adding arguments to. *See*

S

searching for actions, 6

send email, 382

set object user data, 338

set telephony parameter, 340

set user whisper, 334

skills

 assign skills to object action, 162

 remove skills action, 249

speak

 properties, 402, 425, 429, 431

 voices, 405

speech recognition

 application design, 406

standard actions, 155

start speech recognition

 properties, 416

 result codes, 419

 results format string, 420

T

terminus, 45

text-to-speech, 400

U

user control, 260

V

validating workflow, 59, 63

variables

- adding, 120
- assigning value to, 166
- deleting, 127
- deleting all, 128
- purging unused, 129
- system variables, 113
- user-defined variables, 106
- voice calls, workflow for, 16

W

- wait for email, 386, 410
- wait for incoming call, 255
- wait for instant message, 396

workflow

- defined, 1

workflow

- adding a graph, 23, 137, 142, 143, 146, 148, 150
- adding a holiday, 102
- adding a page, 23, 137, 142, 143, 146, 148, 150
- adding actions, 28
- adding an action, 55
- adding variables, 120
- aligning actions, 48
- cutting and copying, 51
- defining a starting point, 45
- deleting a graph, 61, 151, 152
- deleting actions, 58
- deleting all, 62
- email messages, 19, 21
- finding a workflow page, 2

- forming links, 34
- links between pages, 41
- moving actions, 48
- moving links, 53
- searching for actions, 6
- standard action summary, 155
- terminus, 45
- toolbar, 25, 28
- understanding workflow, 16
- validating, 59, 63
- viewing actions, 8
- viewing holidays, 100
- viewing links, 13
- voice calls, 16

workflow actions

- adding to workflow, 55
- allocate speech recognition resource, 410
- assign DN, 160
- assign skills to object, 162
- assign value to variable, 166
- call web service, 294
- check ANI, 171
- check DNIS, 174
- check email, 377
- comment, 181
- compare data, 183
- compose reply, 380
- connector in, 188
- connector out, 190

DB begin transaction, 367
DB close handle, 371
DB connect, 357
DB end transaction, 369
DB execute query, 360
DB next record, 364
dial digits, 192
end workflow session, 225
evaluate expression, 194
execute external action, 308, 311
exit building block routine, 320
free speech recognition resource, 412
get caller input, 213
get object user data, 303
get queue status, 220
get speech recognition result, 414
get telephony parameter, 305
link router, 226
make call, 321
obtain lock action, 329
output debug string, 331
play audio file, 227
play music on hold, 231
queue object, 234
receive instant message, 392
record audio file, 238
reject call, 244
release lock action, 333
remove object from queue, 247
remove skills, 249
reply instant message, 394
route object, 251
send email, 382
set object user data, 338
set telephony parameter, 340
set user whisper, 334
speak, 401
start speech recognition, 416
user control, 260
viewing, 8
wait for email, 386, 410
wait for incoming call, 255
wait for instant message, 396
workflow actions toolbar, 25, 28